



Audi Sport

MEDIA INFO 2016

Audi Sport
Factbook



FOREWORD

No other automobile manufacturer invests as consistently in motorsport as Audi – in the factory backed program just like in customer racing.

The Audi R18, which competes at the 24 Hours of Le Mans and in the WEC, is the flagship for efficiency technologies and future developments. The Audi RS 5 DTM represents top flight touring car racing, which has a magical appeal on a product-loving public.

The new Audi R8 LMS is a genuine sales hit in the fiercely contested GT3 sports car market. With the R8 LMS and Audi TT cup, Audi proves just how fascinating production-based race cars can be.

A whole host of facts and figures about our motorsport program 2016 can be found in this Factbook – accompanied by innumerable illustrations, which are ready for you to download from the Audi MediaCenter.



Jürgen Pippig
AUDI AG
Head of Communications Motorsport

CONTENTS

6 / Audi in motorsport 2016

8 Audi's motorsport program / **10** Management functions /
12 Event calendar / **14** Our race cars / **16** Audi Neuburg /
18 The history of Audi in motorsport

26 / WEC

28 Technology / **36** Basics / **38** Key personnel /
39 Drivers and engineers / **40** Team / **41** Drivers / **48** Circuits /
58 Le Mans / **63** LMP statistics / **66** Partners

68 / DTM

70 Technology / **76** Basics / **80** Key personnel /
82 Teams and drivers / **83** Teams / **86** Drivers / **94** Circuits /
103 Statistics / **106** Partners

108 / GT racing

110 Technology / **114** Global appeal / **116** Contacts /
117 Audi R8 LMS Cup / **118** Audi race experience /
119 Audi Sport racing academy / **120** Statistics / **123** Partners

124 / Audi Sport TT Cup

126 Technology / **130** Basics / **131** Key personnel / **132** Drivers /
136 Circuits / **138** Statistics / **139** Partners

140 / Contacts

CONSUMPTION VALUES

Information about fuel consumption and CO₂ emissions as well as efficiency classes and ranges subject to tires/ tire sets used:

Audi TTS Coupé

Fuel consumption combined: 7.3–6.7 l/100 km

CO₂ emissions combined: 168–155 g/km

Audi A3

Fuel consumption combined: 6.7–3.8 l/100 km

CO₂ emissions combined: 154–99 g/km

Audi Q7

Fuel consumption combined: 8.3–5.5 l/100 km

CO₂ emissions combined: 193–144 g/km

Version: April 28, 2016



AUDI IN MOTORSPORT 2016

8 Audi's motorsport program

10 Key personnel

12 Event calendar

14 Our race cars

16 Audi Neuburg

18 The history of Audi in
motorsport

AUDI'S MOTORSPORT PROGRAM

WEC

Audi R18



#WEC

#LM24

DTM

Audi RS 5 DTM



#RS5DTM

#DTM



2016

GT racing

Audi R8 LMS



#GT3

Audi Sport TT Cup

Audi TT cup



#TTcup



#Audi
#LeagueofPerformance
#AudiSport

 [audi-motorsport.com](https://www.audi-motorsport.com)  [@Audi_Sport](https://www.instagram.com/Audi_Sport)

 [AudiSport](https://www.facebook.com/AudiSport)  [audi_sport](https://www.youtube.com/audi_sport)

MANAGEMENT FUNCTIONS IN AUDI'S MOTORSPORT PROGRAM

Audi Sport



Stefan Dreyer
Head of LMP (from 07/2016)

Continues
on page 38



Dr. Wolfgang Ullrich
Head of Audi Motorsport



Dieter Gass
Head of DTM

Continues
on page 80

Technology



Jörg Zander
Head of Engineering



Axel Löffler
Head of Conceptual
and Full Car Design



Ulrich Baretzky
Head of Engine
Development



Joachim Hausner
Head of Vehicle Opera-
tion Testing/Racing



Norbert Medele
Head of Workshop



Thomas Laudenbach
Head of Electrics,
Electronics, Hybrid



Jan Monchaux
Head of Aerodynamics



Stefan Aicher
Head of Suspension,
Gearbox and Hydraulics

Finance and Organization



Klaus Dieter Krieger
Head of Finance and Organization



Siegfried Krause
Head of
Procurement and
Partnerships



*Rainer
Kammergruber*
Head of Audi
Sport Race
Organization

Customer racing



Stephan Winkelmann
Managing Director
quattro GmbH



Chris Reinke
Head of Audi Sport
customer racing

Continues
— on page 116
and 131



Armin Plietsch
Head of
Engineering



Michael Schäfer
Head of
Production



Dirk Spohr
Head of
Customer
Management

EVENT CALENDAR

WEC

| | | | | | |
|----------|----------|---------------------|----------|-------|------------------|
| 1 | 17/04 | 6h Silverstone (GB) | 6 | 17/09 | 6h Austin (USA) |
| 2 | 07/05 | 6h Spa (B) | 7 | 16/10 | 6h Fuji (J) |
| 3 | 18-19/06 | 24h Le Mans (F) | 8 | 06/11 | 6h Shanghai (CN) |
| 4 | 24/07 | 6h Nürburgring (D) | 9 | 19/11 | 6h Bahrain (BRN) |
| 5 | 03/09 | 6h Mexico (MEX) | | | |

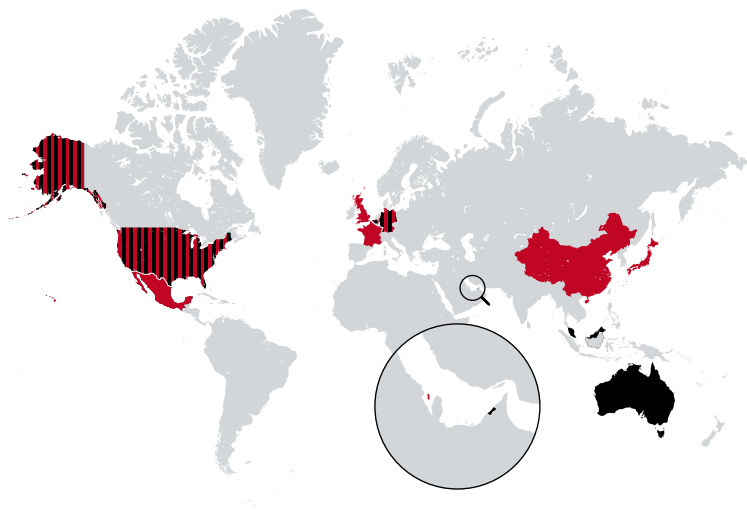

Important 24-hour races

| | | | | | |
|----------|----------|--------------------|----------|----------|---------------------|
| 1 | 15-16/01 | 24h Dubai (VAE) | 5 | 28-29/05 | 24h Nürburgring (D) |
| 2 | 30-31/01 | 24h Daytona (USA) | 6 | 30-31/07 | 24h Spa (B) |
| 3 | 07/02 | 12h Bathurst (AUS) | 7 | 11/12 | 12h Sepang (MAL) |
| 4 | 19/03 | 12h Sebring (USA) | | | |

2016

DTM

- 1** 07-08/05 Hockenheim (D)
- 2** 21-22/05 Spielberg (A)
- 3** 04-05/06 Lausitzring (D)
- 4** 25-26/06 Norisring (D)
- 5** 16-17/07 Zandvoort (NL)

- 6** 20-21/08 Moscow (RUS)
- 7** 10-11/09 Nürburgring (D)
- 8** 24-25/09 Budapest (H)
- 9** 15-16/10 Hockenheim (D)



Audi Sport TT Cup

- 1** 07-08/05 Hockenheim (D)
- 2** 27-28/05 Nürburgring (D)
- 3** 25-26/06 Norisring (D)
- 4** 16-17/07 Zandvoort (NL)

- 5** 10-11/09 Nürburgring (D)
- 6** 24-25/09 Budapest (H)
- 7** 15-16/10 Hockenheim (D)

OUR RACE CARS

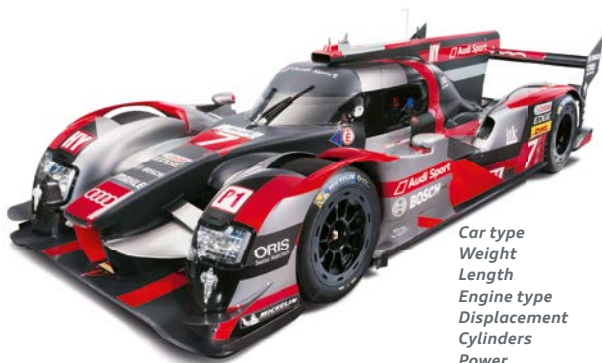

Audi R18

| | |
|--------------------|------------------------|
| Car type | LMP1 sports car |
| Weight | 875 kg |
| Length | 4,650 mm |
| Engine type | TDI |
| Displacement | 4,000 cc |
| Cylinders | V6 |
| Power | 728 kW ¹ |
| Power/weight ratio | 1.2 kg/kW ¹ |
| 0-100 km/h | 2.6s |
| Top speed | 324 km/h |

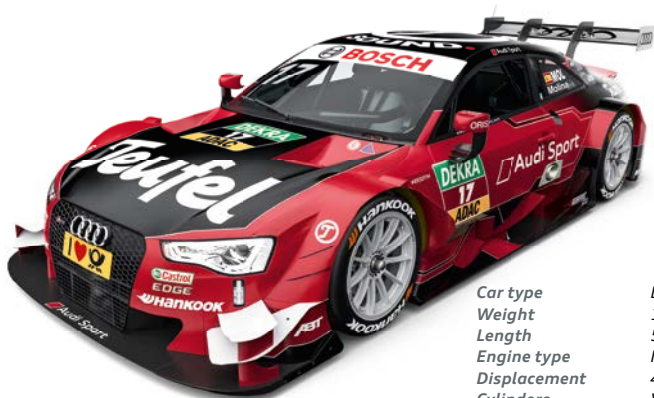

Audi RS 5 DTM

| | |
|--------------------|-------------------------|
| Car type | DTM touring car |
| Weight | 1,120 kg (incl. driver) |
| Length | 5,010 mm |
| Engine type | Normally aspirated |
| Displacement | 4,000 cc |
| Cylinders | V8 |
| Power | 340 kW |
| Power/weight ratio | 3.3 kg/kW |
| 0-100 km/h | 2.9s |
| Top speed | 280 km/h |

2016

¹With Hybrid



Audi R8 LMS

| | |
|--------------------|--------------------|
| Car type | GT3 sports car |
| Weight | 1,225 kg |
| Length | 4,583 mm |
| Engine type | Normally aspirated |
| Displacement | 5,200 cc |
| Cylinders | V10 |
| Power | 430 kW |
| Power/weight ratio | 2.8 kg/kW |
| 0-100 km/h | 3.2s |
| Top speed | 305 km/h |



Audi TT cup

| | |
|--------------------|----------------------------|
| Car type | Cup touring car |
| Weight | 1,125 kg |
| Length | 4,260 mm |
| Engine type | TFSI |
| Displacement | 1,984 cc |
| Cylinders | 4 (inline) |
| Power | 228 kW/250 kW ¹ |
| Power/weight ratio | 4.9 kg/kW |
| 0-100 km/h | 4.5s |
| Top speed | 239 km/h |

¹With Push-to-pass

AUDI NEUBURG

- / Audi driving experience center
- / Competence Center Motorsport/
Audi Sport
- / Audi Sport customer racing
- / Development functions of
Technical Development

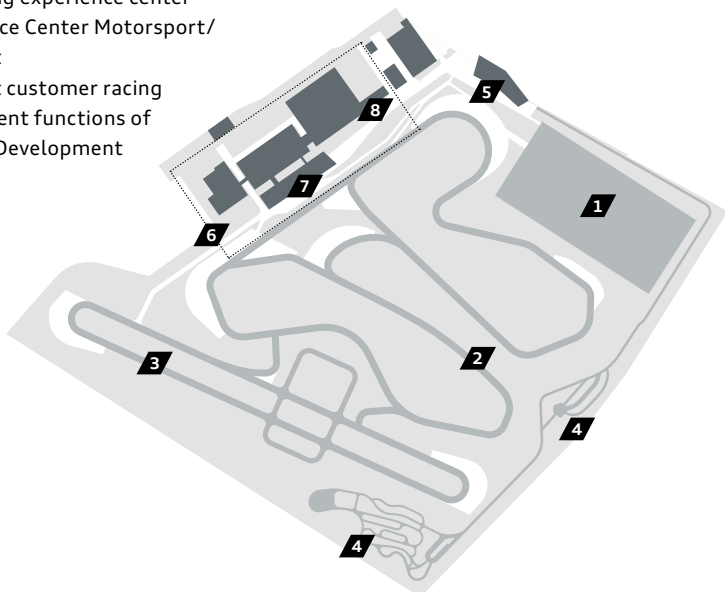

2010-2011
Land purchase
and drafting of
development plan

August 2012
Ground-breaking
ceremony

May 2014
Commissioning
Audi driving
experience center

May 2015
Commissioning
Audi Sport
customer racing

2011-2012
Planning stage

November 2013
Topping-out ceremony
Motorsport building

August 2014
Opening Audi Neuburg /
Commissioning Competence
Center Motorsport/ Audi Sport

2016

1 **30,000 m²**
Vehicle dynamics test area

2 **2.2 km**
Handling circuit

3 **1.2 km**
Straight

4 **10**
Off-road modules

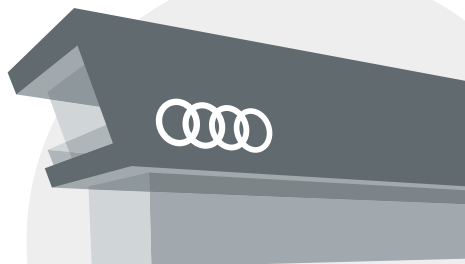

5 Audi driving experience center

6 Competence Center Motorsport

7 Audi Sport

8 Audi Sport customer racing

Awards

Audi driving
experience center



The German Sustainable
Building Council (DGNB)

Competence Center
Motorsport



Trade exhibition 'Professional
MotorSport World Expo'

Software 'Audi Multi Media
System Octopus' in Audi
driving experience center



Association 'Point of Purchase
Advertising International'

THE HISTORY OF AUDI IN MOTORSPORT

Key

Head of Audi Sport

D Victory/Title Driver

M Victory/Title Manufacturer

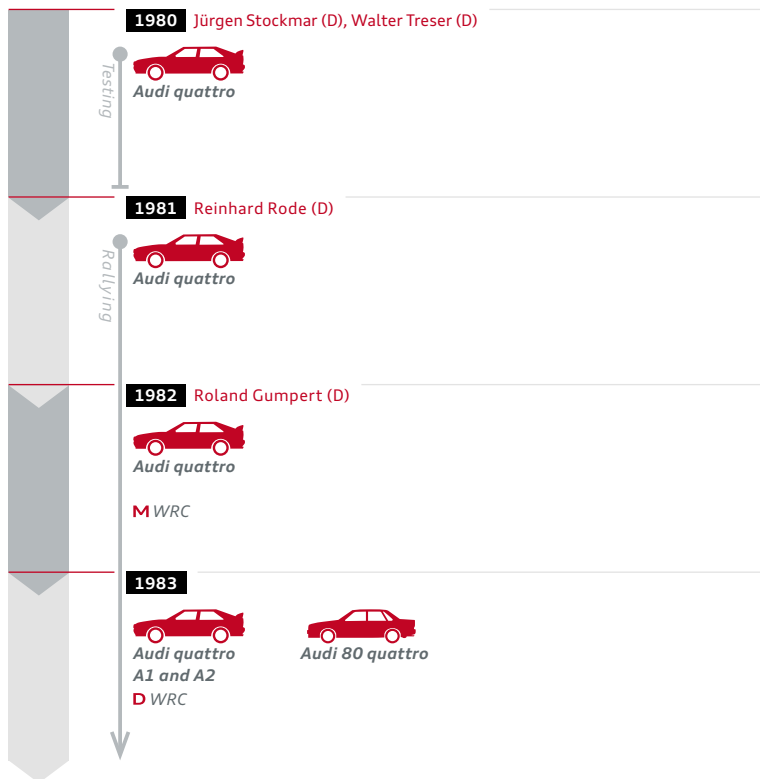

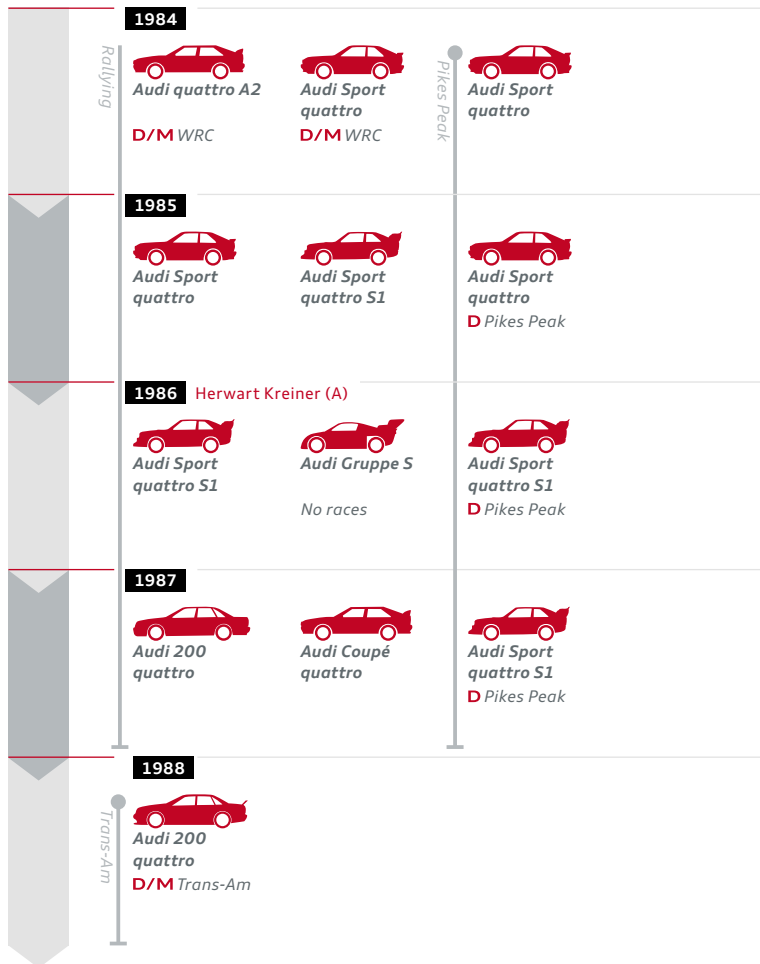

1989

IMSA GTO



Audi 90 quattro

1990

DTM



Audi V8 quattro

D DTM

1991 Dieter Basche (D)



Audi V8 quattro

D DTM

1992



Audi V8 quattro



*Audi 80 DTM
Class 1*

No races

1993 Dr. Wolfgang Ullrich (A)

Super Touring
Cars



Audi 80 quattro

D/M STC France

2016

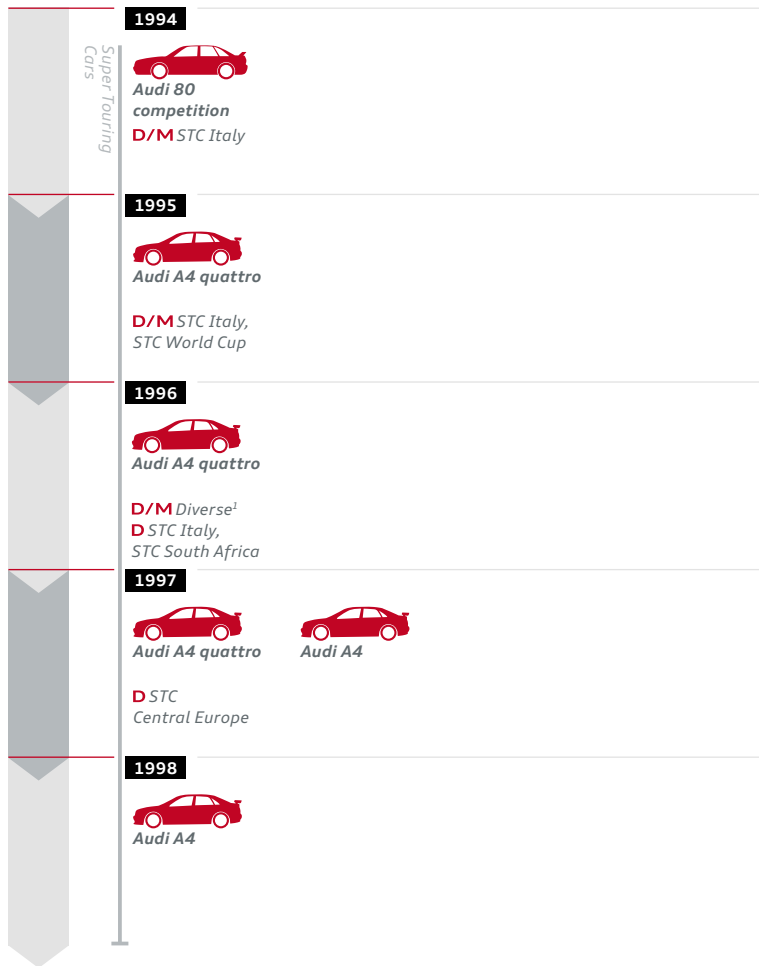

¹ STC Australia, Belgium, Germany, Great Britain, Spain

1999

Sports car
LMP



Audi R8R

Sports car
LMGT-P



Audi R8C

2000



Audi R8



Audi R8R

D/M ALMS
D 24h Le Mans

2001



Audi R8

D/M ALMS
D 24h Le Mans,
ELMS

2002



Audi R8

D/M ALMS
D 24h Le Mans

2003



Audi R8

D/M ALMS

2016

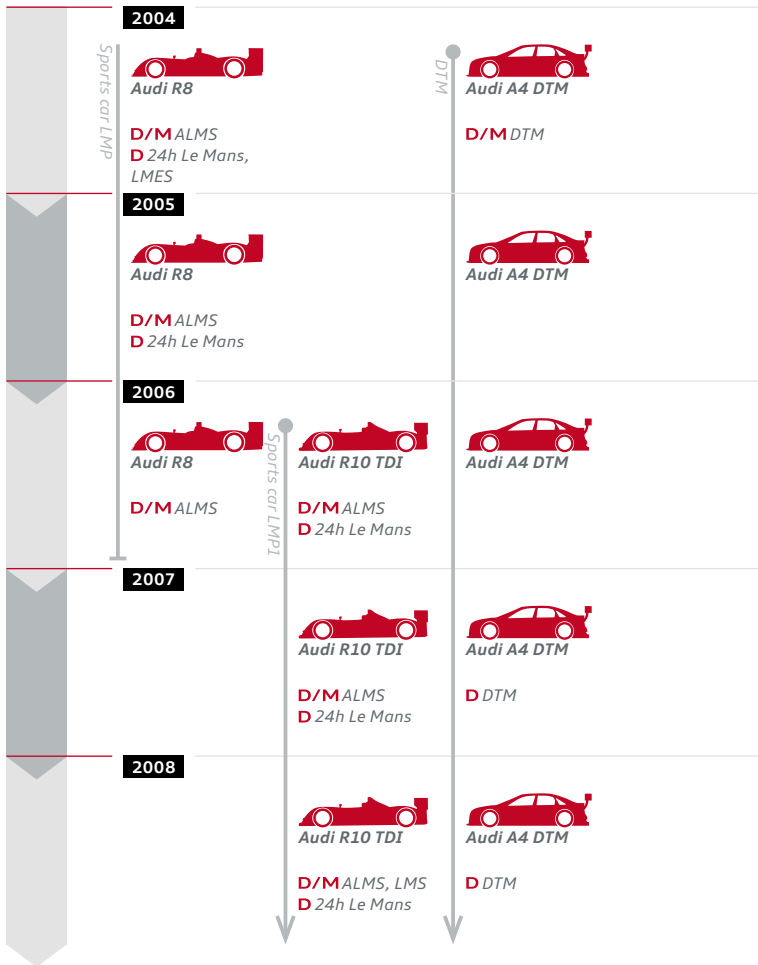

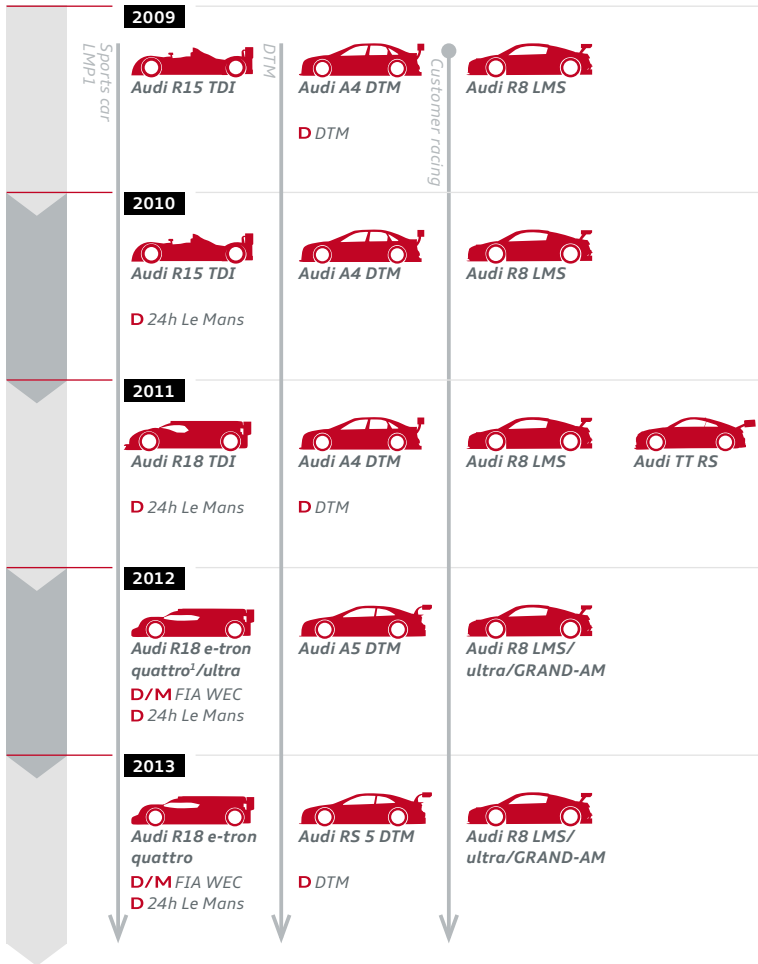

2016

¹ Only the Audi R18 e-tron quattro took the victories

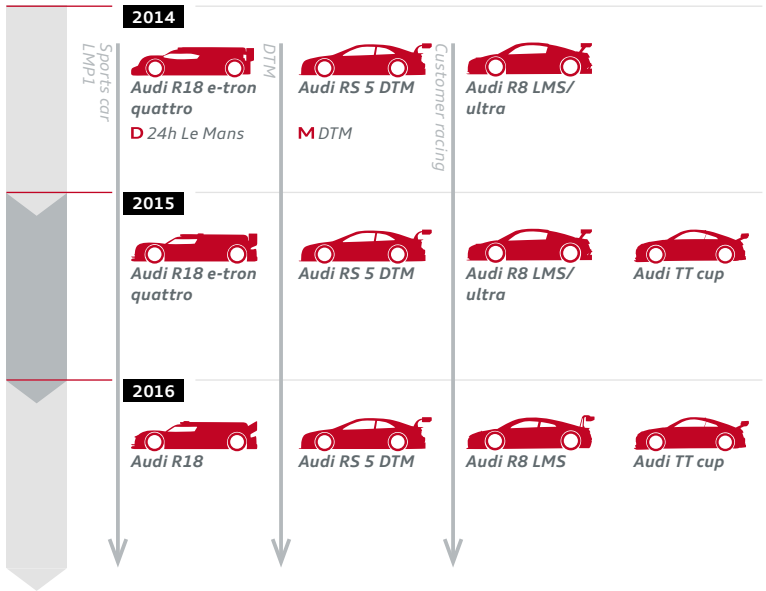



WEC

- 28 Technology
- 36 Basics
- 38 Key personnel
- 39 Drivers and engineers
- 40 Team
- 41 Drivers
- 48 Circuits
- 58 Le Mans
- 63 LMP statistics
- 66 Partners

INNOVATIONS AT LE MANS

2001

TFSI technology

2006

TDI technology / LED daytime driving lights

2009

Lithium ion battery / V10 TDI replaces V12 TDI / Turbocharger with VTG control

2010

LED light technology

2011

Downsizing from V10 TDI (5.5 liter) to V6 TDI (3.7 liter) / Dual-flow pressurized mono turbocharger / Full LED headlights / Intensification of ultra lightweight design

2012

Hybrid drive e-tron quattro with hybrid powertrain 150 kW / Matrix LED headlights

2013

Power increase of hybrid system to more than 160 kW

2014

Efficiency regulations (consumption reduction compared to 2006: minus 38 per cent) / V6 TDI (4 liter) / Audi Laserlight / Optimization lightweight design: first Audi LMP race car which is lighter than 900 kg (870 kg) / Power increase of hybrid system to more than 170 kW / Accumulator capacity 600 kJ / Reduction of car and tire width / Significant aerodynamic optimization

2015

Redesign of V6 TDI to further reduce consumption / Power increase of hybrid system to more than 200 kW, accumulator capacity 700 kJ / Further optimization of lightweight design / Significant aerodynamic optimization

2016

V6 TDI reworked, consumption reduced by approx. 9.79 per cent / Hybrid drive performance increase to more than 350 kW (+106 %) / Lithium ion battery replaces flywheel accumulator as storage medium / Further optimizations in the aerodynamics and lightweight design, power transmission and suspension

EFFICIENCY IMPROVEMENTS AT LE MANS

Fuel consumption -33%

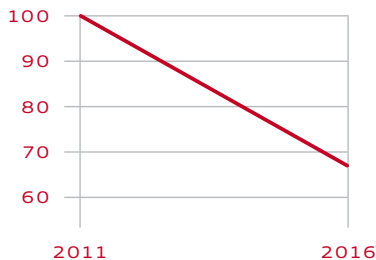

/ Since Audi has competed at Le Mans with the V6 TDI (2011), the energy consumption has fallen by around 67 per cent per lap (calculated for 2016)

Average speed +3.77%

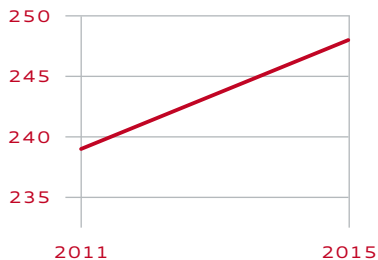

/ In contrast, the average speed, measured on the fastest lap of the fastest Audi, increased from 239 km/h (2011) to 248 km/h (2015)

AUDI R18: HYBRID SYSTEM

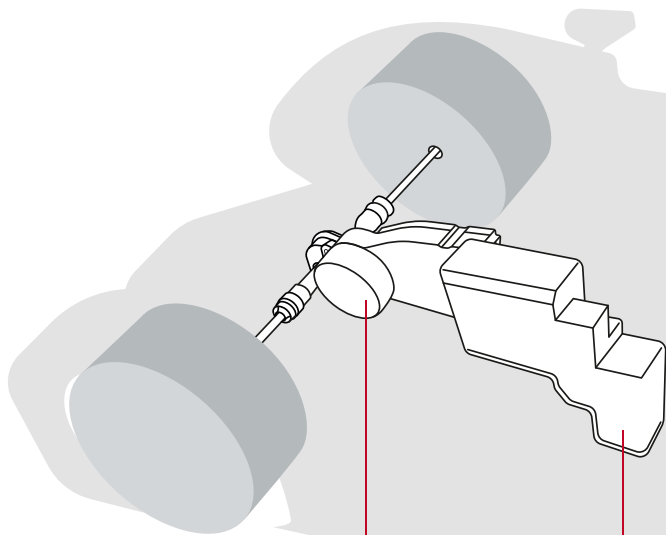

MGU

The Motor Generator Unit (MGU) converts the kinetic energy recovered during braking into electricity. And vice versa, the MGU can drive the front axle with the energy recovered.

Battery

Audi relies on a lithium ion battery as storage medium for the hybrid system for the first time. The battery cells are connected in series and produce a voltage swing of more than 2 mega joules of energy. The thermal management is made via a low temperature circuit comprised of micro channel elements.

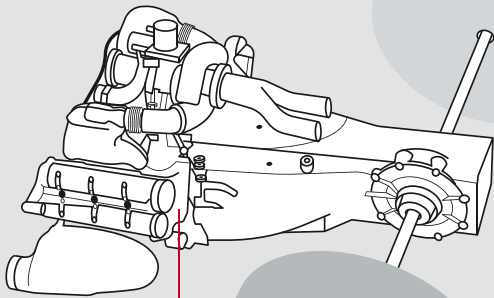

V6 TDI engine

The powerful and efficient V6 TDI with more than 514 hp drives the rear axle. It consumes 46 per cent less energy than Audi's first V12 TDI used at Le Mans in 2006.

THE NEW AUDI R18

Recuperated hybrid energy

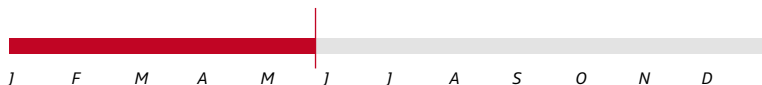
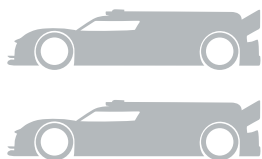

- / Two Audi R18 boost a total of 4,716 Megajoules over the distance of a complete 24-hour race at Le Mans¹
- / 4,716 Megajoules equal 1,310 kWh
- / A German two person household uses 3,248 kWh per annum²
- / With the energy boosted, you could supply this household for 147.3 days assuming constant consumption – from January 1 to May 27

Overall power

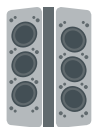

>514 hp
Combustion engine

+



>476 hp
Hybrid system

≈



1,000 hp
Total power

AUDI R18: ENGINE

VTG turbocharger

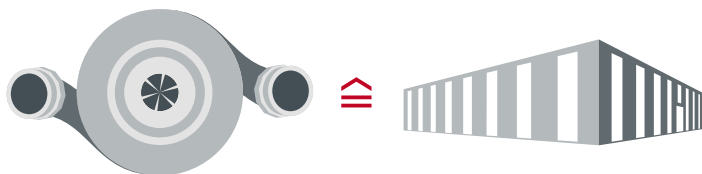

- / Supplies 2,000 kg air per hour at full load
- / At an air density of 1.3 kg/m^3 the resulting volume is $1,538.46 \text{ m}^3$

- / Equates to the content of an empty factory building with internal dimensions of 15.38 meters long, 10 meters wide and 10 meters high

V6 TDI injection pressure

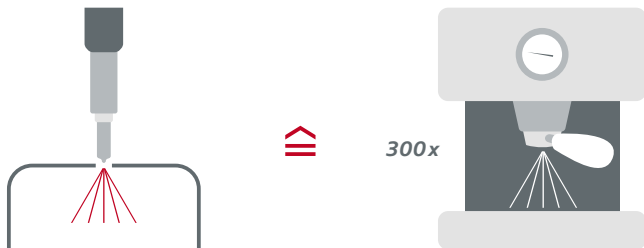

- / The diesel fuel is injected at a pressure of 3,000 bar into the combustion chamber of the V6 TDI powering the R18

- / To compare: the pressure is 300 times greater than the brewing pressure used by an Espresso machine

COCKPIT AUDI R18

Fire extinguisher ('E')
High Voltage System Status (red/green)
High beam (yellow)
Hybrid function (toggle switch)

*AMOLED screen for digital
rearview mirror*

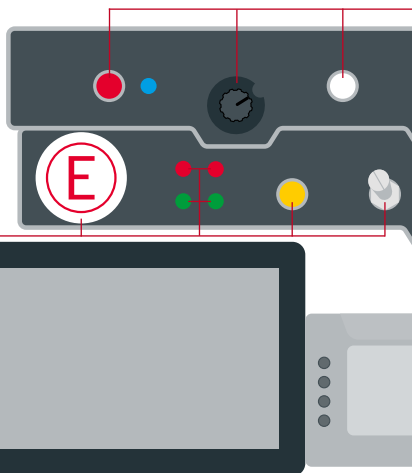

Brake balance (blue)
Traction control TC (red)
*With adjustment in opposite
direction on other side*

Paddles
Headlight flash (top)
Downshift (middle)
Clutch (bottom)

Pit function (yellow)
Hybrid function (blue)
Radio (blue)
Drink system (green)
Engine start (red)

Multifunction rotary switch *Display*

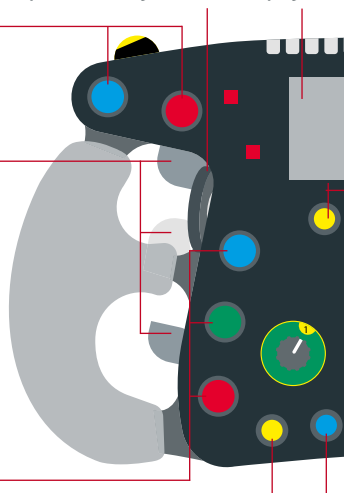

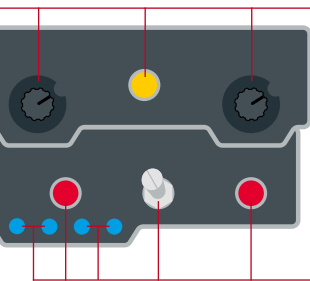

Reset function for fuses (red)
Radio volume (rotary switch, left)
Neutral (white)
Tire setting (rotary switch, middle)
Reverse gear (yellow)
Brake setting (rotary switch, right)

Tire slip indicator (blue)
Data function (red, left)
Main switch (toggle switch)
Fog light (red, right)



Information from the race stewards
e.g. flag signals

Full course yellow (yellow)
Menu guide (white)
Safety car (blue)

Balance settings

Gear shift lights

Fuel function
Identical function
on opposite side

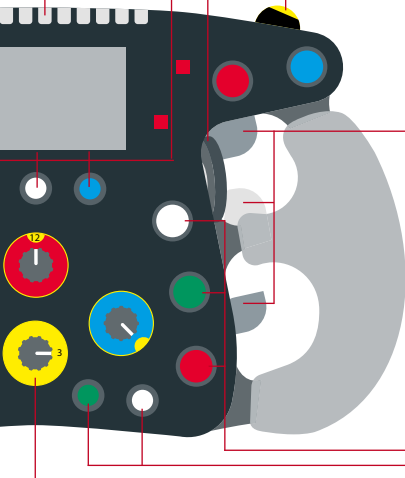

Paddles
Fuel function (top)
Upshift (middle)
Clutch (bottom)

Pit speed limit (white)
Confirm button (green)
Engine start (red)

Windscreen clean (green)
Fuel function (white)

Rotary switch
Windscreen wiper (green)
Engine map (red)
Hybrid system (yellow)
TC setting (blue)

BASICS FIA WORLD ENDURANCE CHAMPIONSHIP (WEC)

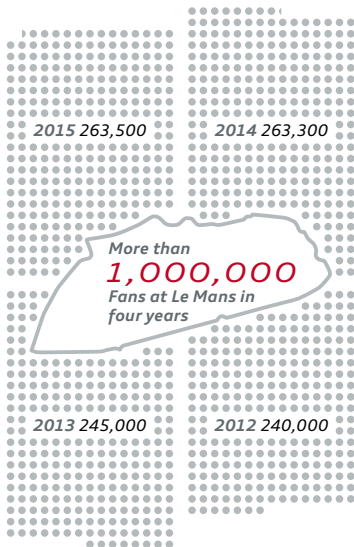
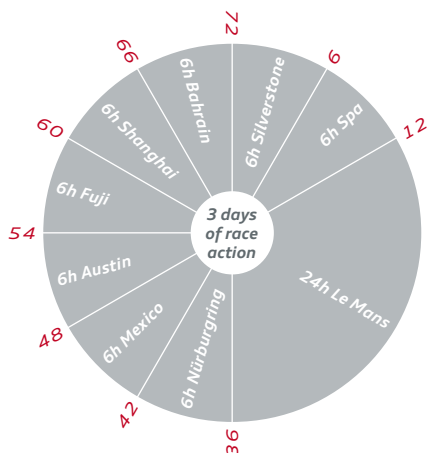

Classes

| | LMP1 | LMP2 |
|---------------------|--|---|
| Race car | Closed prototype | Open or closed prototype |
| Categories | With energy recuperation (hybrid) for manufacturers and without hybrid for private teams | - |
| Price | - | Max 388,500 € Max 463,500 € (closed car) |
| Displacement | Free (hybrid) Max 5,500 cc (without hybrid) | Max 5,000 cc (normally aspirated) Max 3,200 cc (turbo) |
| Cylinders | Free | Max 8 (normally aspirated) Max 6 (turbo) |
| Weight | Min 875 kg (hybrid) Min 855 kg (without hybrid) | Min 900 kg |
| Length | Max 4,650 mm | Max 4,650 mm |
| Width | 1,800–1,900 mm | Max 2,000 mm |
| Driver | Bronze drivers not permitted | Minimum 1 bronze or silver driver per car |

Example of a pit stop

Phase 1: refueling

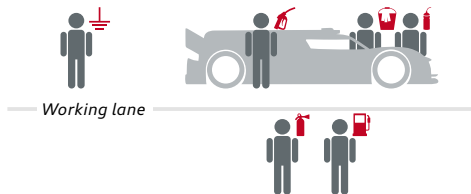

In the working lane

- / 1 attaches the earth strap,
- 1 person refuels
- / Optional: 1 person cleans,
- 1 driver helper

Behind the working lane

- / 1 person with fire extinguisher
- / 1 person on the valve of the fuelling rig

Phase 2: tire change (and driver change)

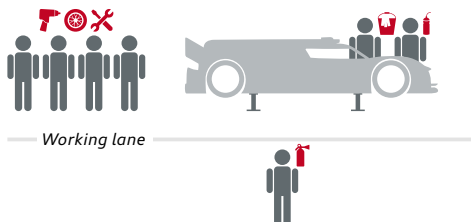

In the working lane

- / 4 people share the tire change, repairing, refilling oil or similar; maximum 1 wheel gun allowed
- / Optional: 1 person cleans,
- 1 driver helper

Behind the working lane

- / 1 person with fire extinguisher

GTE-PRO

GT sports car with 2 doors

-

-

Max 5,500 cc (normally aspirated)

Max 4,000 cc (turbo)

Free

Min 1,245 kg

Max 4,800 mm

Max 2,050 mm

Free

GTE-AM

GT sports car with 2 doors

Cars must be at least 1 year old

-

Max 5,500 cc (normally aspirated)

Max 4,000 cc (turbo)

Free

Min 1,245 kg

Max 4,800 mm

Max 2,050 mm

Min 1 bronze and 1 bronze or silver driver per car

KEY PERSONNEL IN THE LMP PROGRAM



*Stefan Dreyer
Head of LMP (from 07/2016)*



*Tristan Summerscale
Project Manager
Vehicle Development*



*Hartmut Diel
Project Manager
Engine Development*



*Andreas Roos
Project Manager
Racing*



*Dominic Zeitler
Project Manager
Testing*



*Dieter Meissler
Project Manager
Vehicle Build-up*



*Holger Turczynski
Project Manager Electronics,
Electronics, Hybrid*



*Elmar Adler
Partnerships*



*David Pfanner
Technical Team
Coordinator*

Audi Sport Team Joest



*Reinhold Joest
Team Owner*



*Ralf Jüttner
Team Director*



*Sigrun Eith-Jüttner
Organization and
Administration*

DRIVERS AND ENGINEERS

#7 Audi R18

Marcel Fässler (CH)

André Lotterer (D)

Benoît Tréluyer (F)



*Leena Gade
Car engineer*



*Erik Schuivens
Car engineer*

R18 #7 (up to 06/2016) R18 #7 (from 07/2016)



#8 Audi R18

Lucas di Grassi (BR)

Loïc Duval (F)

Oliver Jarvis (GB)



*Justin Taylor
Car engineer
R18 #8*



AUDI SPORT TEAM JOEST

1978

Founded

Since 1999

Partner of Audi

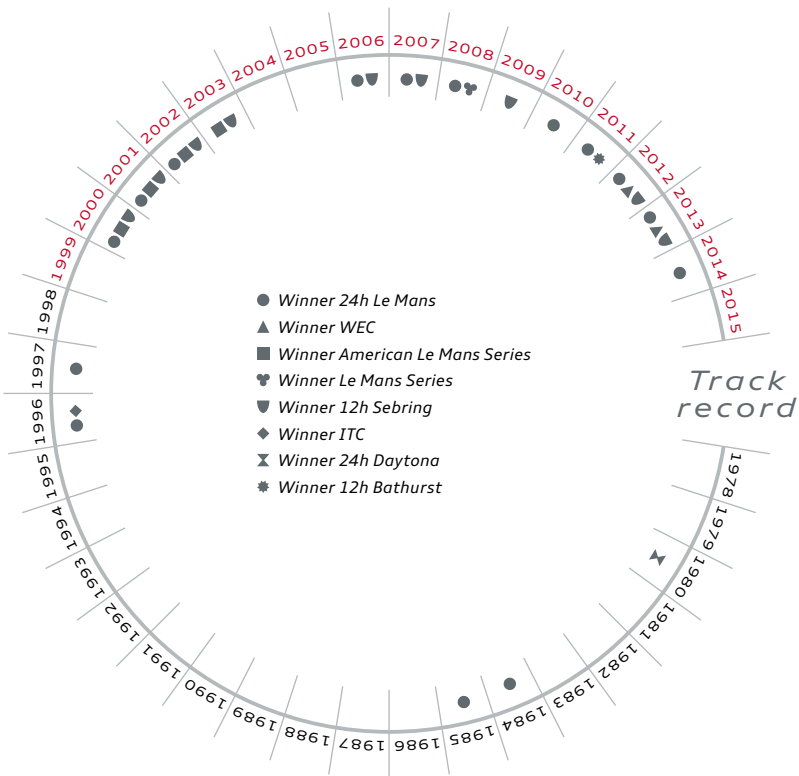



#8 LUCAS DI GRASSI



1.79 m

* August 11, 1984, São Paulo (BR)
▲ Monaco (MC)

Hobby







Triathlon

Marital status



Married

Statistics

| | WEC | Le Mans |
|---|-----------------------|-------------------------|
|  Best table ranking | 4 th 2x | |
|  Number of races | 19 | 3 |
|  Best grid position ¹ | 2 nd 4x | 2 nd 2013 |
|  Best result | 2 nd 3x | 2 nd 2014 |

¹ Car grid position

Career highlights

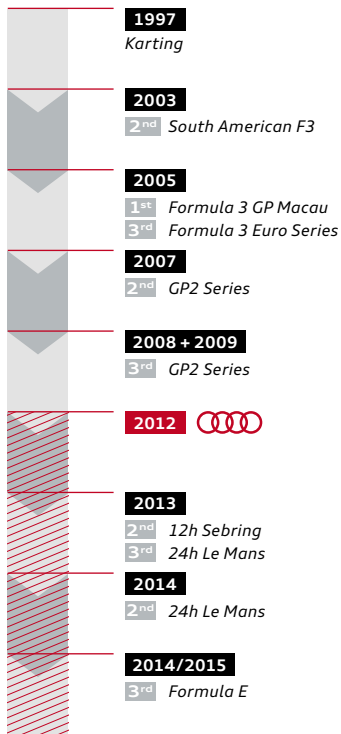

 lucasdigrassi.com.br

 [lucasdigrassiofficial](https://www.facebook.com/lucasdigrassi)

 [@lucasdigrassi](https://twitter.com/lucasdigrassi)

 [lucasdigrassi](https://www.instagram.com/lucasdigrassi)



#8 LOIC DUVAL



* June 06, 1982, Chartres (F)
▲ Geneva (CH)





Hobbies



Marital status



Statistics

| | WEC | Le Mans |
|--|-------------------------------|-------------------------------|
|  Best table ranking | 1st 2013 | |
|  Number of races | 26 | 6 |
|  Best grid position ¹ | 1st 2x | 1st 2013 |
|  Best result | 1st 4x | 1st 2013 |

Career highlights

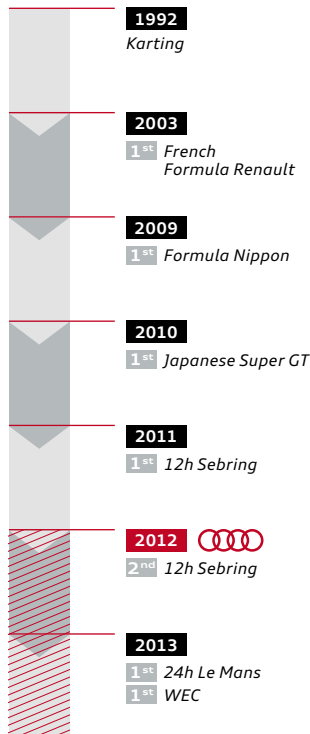

 loicduval.com
 [loic.duval.official](https://www.facebook.com/loic.duval.official)
 [@loicduval](https://twitter.com/loicduval)
 [loicduval](https://www.instagram.com/loicduval)



#7 MARCEL FÄSSLER



1.78 m

* May 27, 1976, Einsiedeln (CH)

▲ Gross (CH)

Hobbies



Mountain biking



Skiing

Marital status



Married



4 daughters

Statistics

| | WEC | Le Mans |
|---------------------------------|-------------------------------|-----------------------------|
| Best table ranking | 1st 2012 | |
| Number of races | 32 | 10 |
| Best grid position ¹ | 1st 6x | 1st 2x |
| Best result | 1st 10x | 1st 3x |

Career highlights

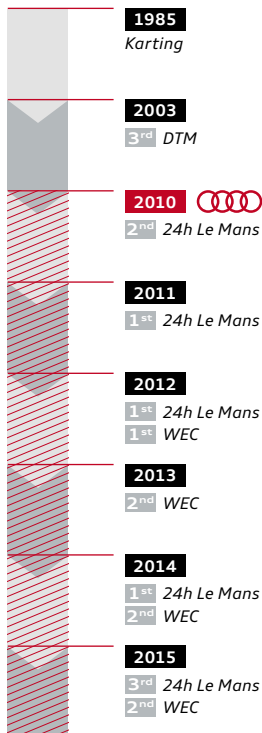

 marcel-faessler.ch

 [marcel-faessler-433092060095169](https://www.facebook.com/marcel-faessler-433092060095169)

 [marcel_faessler](https://www.instagram.com/marcel_faessler)

¹ Car grid position



#8 OLIVER JARVIS



1.80 m

* January 09, 1984, Burwell (GB)
▲ Burwell (GB)

Hobbies



Soccer



Tennis

Marital status





Married



1 daughter

Statistics

| | WEC | Le Mans |
|--|-------------------------|-------------------------|
|  Best table ranking | 4 th 2015 | |
|  Number of races | 13 | 5 |
|  Best grid position ¹ | 2 nd 3x | 2 nd 2013 |
|  Best result | 3 rd 5x | 3 rd 2x |

Career highlights

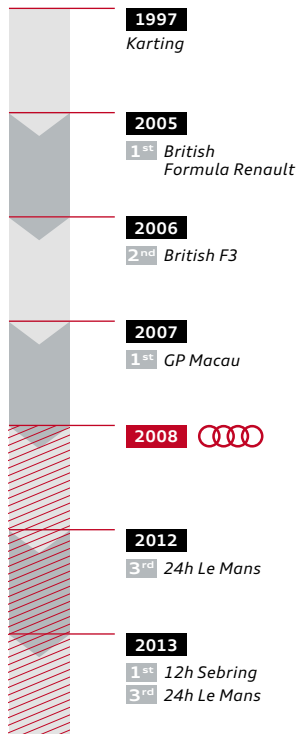

 oliverjarvis.com

 [olly.jarvis.73](https://www.facebook.com/olly.jarvis.73)

 [@ollyjarvis](https://twitter.com/@ollyjarvis)

 [oliverjarvis1](https://www.instagram.com/oliverjarvis1)



#7 ANDRÉ LOTTERER



* November 19, 1981, Duisburg (D)
▲ Tokyo (J)

Hobbies



Mountain biking







Single



Cycling

Marital status

Statistics

| | WEC | Le Mans |
|---|-------------------------------|-----------------------------|
|  Best table ranking | 1st 2012 | |
|  Number of races | 32 | 7 |
|  Best grid position ¹ | 1st 6x | 1st 2x |
|  Best result | 1st 10x | 1st 3x |

¹ Car grid position

Career highlights

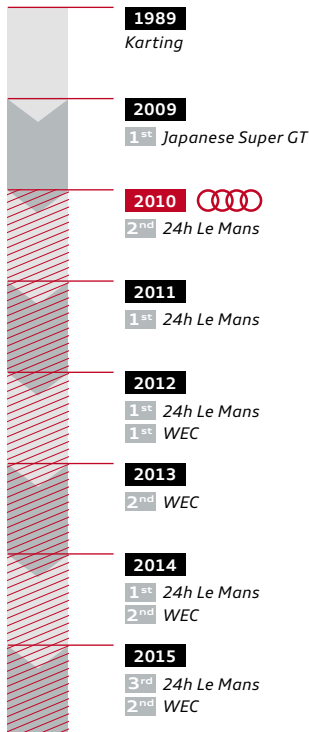

 alotterer

 @andre_lotterer

 andre_lotterer



RENÉ RAST¹



1.79 m

* October 26, 1986, Minden (D)
▲ Frankfurt (D)

Hobbies

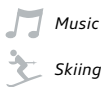

Music





Skiing

Marital status





Single

Statistics

| | WEC | Le Mans |
|--|--------------------------|-------------------------|
|  Best table ranking | 12 th 2015 | |
|  Number of races | 3 | 2 |
|  Best grid position ² | 6 th 2015 | 6 th 2015 |
|  Best result | 4 th 2015 | 7 th 2015 |

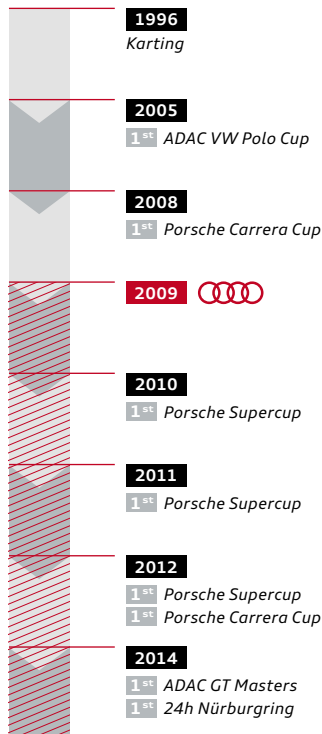
Career highlights



 rene-rast.de

 [rené-rast-438204456206325](https://www.facebook.com/rené-rast-438204456206325)

 [@renerastracing](https://twitter.com/renerastracing)

WEC

¹ Reserve driver
² Car grid position



#7 BENOÎT TRÉLUYER



1.78 m

* December 07, 1976, Alençon (F)
▲ Gordes (F)

Hobbies



Motocross



Mountain biking

Marital status







Married



1 son

Statistics

| | WEC | Le Mans |
|---|-------------------------------|-----------------------------|
|  Best table ranking | 1st 2012 | |
|  Number of races | 32 | 11 |
|  Best grid position ¹ | 1st 6x | 1st 2x |
|  Best result | 1st 10x | 1st 3x |

¹ Car grid position

Career highlights

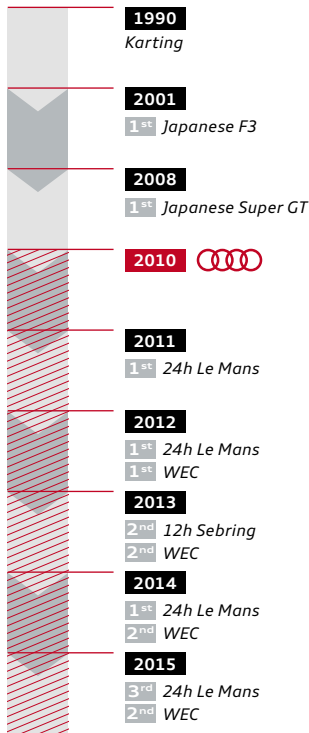

 benoittréluyer.com

 [benoittréluyer](https://www.facebook.com/benoittréluyer)

 [@benoittréluyer](https://twitter.com/benoittréluyer)

1 6H SILVERSTONE, 17/04

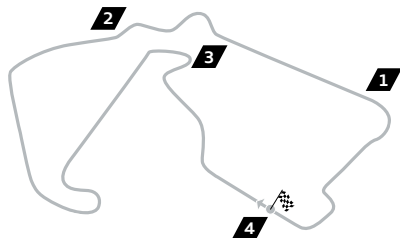

5.891 km *Circuit length*

approx. 210 km/h
Average speed

34 *Gearshifts per lap*

1m 39.721s
Lap record qualifying
Webber/Hartley (Porsche), 2015

1m 40.836s
Lap record race
Benoît Tréluyer (Audi), 2015

- 1 *Top speed 274 km/h*
- 2 *Fastest corner 270 km/h*
- 3 *Slowest corner 74 km/h*
- 4 *Permitted hybrid energy 4.02 MJ*

Audi's WEC track record at Silverstone

- 4 *Races*
- 1 *1-2 & 1-2-3 finish*
- 1 *Pole position*
- 3 *Wins*
- 5 *Podiums*
- 3 *Fastest race laps*

Audi market data in Great Britain 2015

- / *Delivery volume: 166,817 units*
- / *Growth compared to 2014: 5.0 per cent*



-  *Silverstone Circuit*
-  *London*

2 6H SPA, 07/05

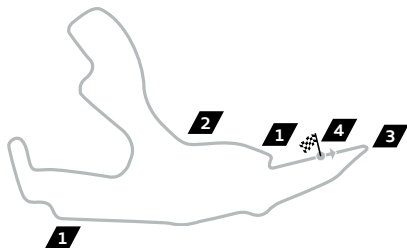

- 1** Top speed 295 km/h
- 2** Fastest corner 287 km/h
- 3** Slowest corner 65 km/h
- 4** Permitted hybrid energy 4.78 MJ

7.004 km Circuit length

approx. 220 km/h
Average speed

46 Gearshifts per lap

1m 54.767s
Lap record qualifying
Bernhard/Hartley (Porsche), 2015

1m 57.972s
Lap record race
Brendon Hartley (Porsche), 2015

Audi's WEC track record at Spa

- | | | |
|----------------|-------------------------------|----------------------------|
| 4 Races | 2 1-2 & 1-2-3 finishes | 2 Pole positions |
| 3 Wins | 8 Podiums | 2 Fastest race laps |

Audi market data in Belgium 2015

- / Delivery volume: 32,000 units
- / Audi A3¹ best selling model
- / Production site: Brussels

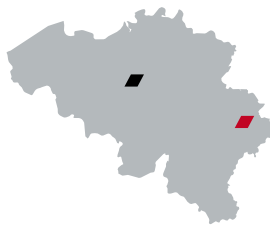

-  Circuit de Spa-Francorchamps
-  Brussels

¹ Please refer to the list on page 5 for the consumption and emission values

3 24H LE MANS, 18-19/06

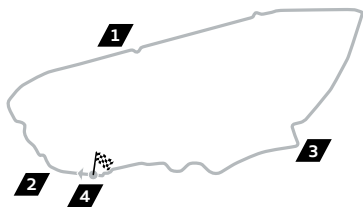

- 1** Top speed 316 km/h
- 2** Fastest corner 271 km/h
- 3** Slowest corner 74 km/h
- 4** Permitted hybrid energy 6.00 MJ

13.629 km Circuit length

approx. 250 km/h
Average speed

62 Gearshifts per lap

3m 16.887s
Lap record qualifying
Neel Jani (Porsche), 2015

3m 17.475s
Lap record race
André Lotterer (Audi), 2015

Site map

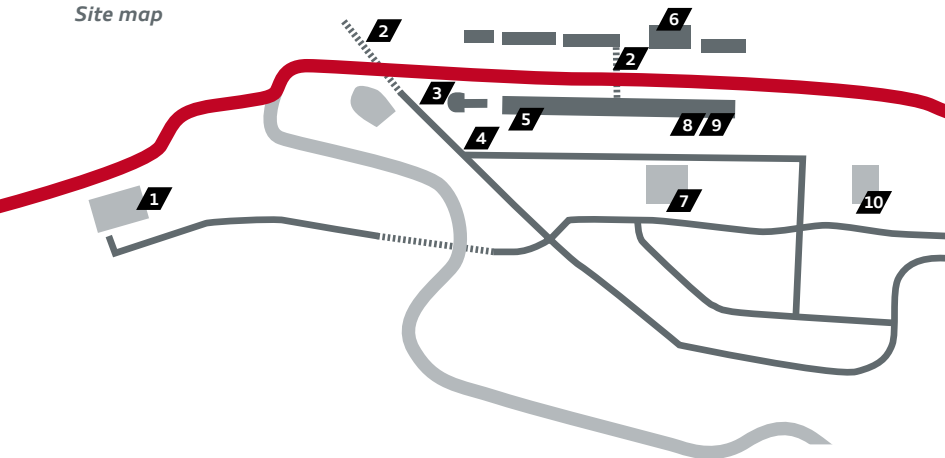

Audi's WEC track record at Le Mans

| | | |
|----------------|-------------------------------|----------------------------|
| 4 Races | 2 1-2 & 1-2-3 finishes | 2 Pole positions |
| 3 Wins | 8 Podiums | 4 Fastest race laps |

Audi market data in France 2015

/ Delivery volume: 60,216 units

/ Growth compared to 2014:

5.7 per cent

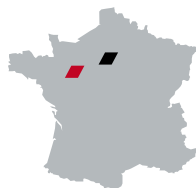

 Circuit des 24 Heures
 Paris

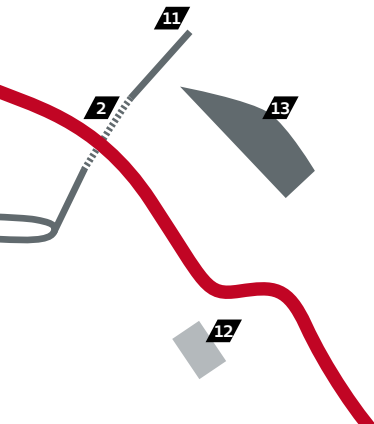

Key

- 1** Audi Racing Arena, Audi Press Conference (Parc du Raccordement)
- 2** Tunnel
- 3** Race direction
- 4** Paddock entrance
- 5** Media Center
- 6** Audi Racing Club
- 7** Audi Team and Media Hospitality (paddock)
- 8** Audi Sport Team Joest, Pit 45, 46
- 9** Audi Racing Lounge, No. 145/146
- 10** Audi Racing Garden, Audi Racing Shop, Audi Tower
- 11** Circuit entrance
- 12** Audi Fan Area
- 13** Museum

4 6H NÜRBURGRING, 24/07

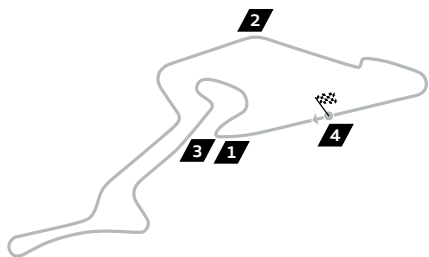

5.137 km *Circuit length*

approx. 190 km/h
Average speed

52 *Gearshifts per lap*

1m 36.473s
Lap record qualifying
Dumas/Lieb (Porsche), 2015

1m 37.955s
Lap record race
Neel Jani (Porsche), 2015

- 1** Top speed 265 km/h
- 2** Fastest corner 222 km/h
- 3** Slowest corner 69 km/h
- 4** Permitted hybrid energy 3.51 MJ

Audi's WEC track record at the Nürburgring

1 Races

0 1-2 & 1-2-3 finishes

0 Pole positions

0 Wins



1 Podium

0 Fastest race laps

Audi market data in Germany 2015

- / Delivery volume: 270,063 units
- / Growth compared to 2014:
5.7 per cent
- / Production sites: Ingolstadt,
Neckarsulm



 Nürburgring
 Berlin

5 6H MEXICO, 03/09

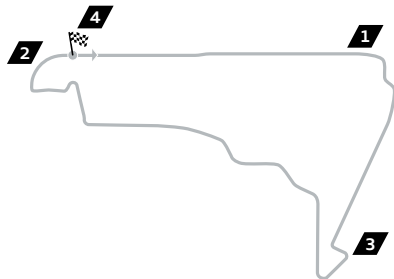

4.304 km Circuit length

— Average speed

30 Gearshifts per lap

— Lap record qualifying

— Lap record race

- 1** Top speed 292 km/h
- 2** Fastest corner 179 km/h
- 3** Slowest corner 58 km/h
- 4** Permitted hybrid energy 2.94 MJ

Audi's WEC track record in Mexico

- Races
- Wins
- 1-2 & 1-2-3 finishes
- Podiums
- Pole positions
- Fastest race laps

Audi market data in Mexico 2015

- / Delivery volume: 14,147 units
- / Growth compared to 2014: 9.3 per cent
- / Production site: San José Chiapa



-  Autodromo Hermanos Rodriguez
-  Mexico City

6 6H AUSTIN, 17/09

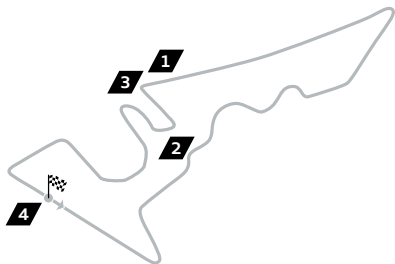

5.513 km *Circuit length*

approx. 185 km/h
Average speed

52 *Gearshifts per lap*

1m 46.211s
Lap record qualifying
Jani/Lieb (Porsche), 2015

1m 47.375s
Lap record race
Benoît Tréluyer (Audi), 2013

1 *Top speed 276 km/h*

2 *Fastest corner 242 km/h*

3 *Slowest corner 65 km/h*

4 *Permitted hybrid energy 3.76 MJ*

Audi's WEC track record in Austin

3 *Races*

1 *1-2 & 1-2-3 finish*

1 *Pole position*

2 *Wins*

6 *Podiums*

1 *Fastest race lap*

Audi market data in the USA 2015

/ Delivery volume: 202,202 units

/ Growth compared to 2014:

11.1 per cent

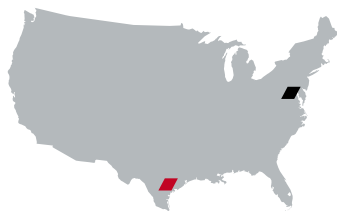

 *Circuit of The Americas*

 *Washington D.C.*

7 6H FUJI, 16/10

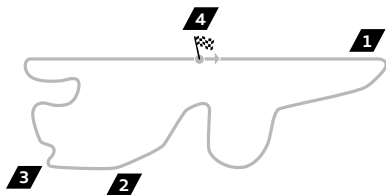

- 1** Top speed 296 km/h
- 2** Fastest corner 247 km/h
- 3** Slowest corner 65 km/h
- 4** Permitted hybrid energy 3.11 MJ

4.563 km Circuit length

approx. 200 km/h
Average speed

38 Gearshifts per lap

1m 22.763s
Lap record qualifying
Bernhard/Webber (Porsche), 2015

1m 25.621s
Lap record race
Loïc Duval (Audi), 2015

Audi's WEC track record at Fuji

- | | | |
|----------------|-------------------------------|----------------------------|
| 4 Races | 0 1-2 & 1-2-3 finishes | 1 Pole position |
| 0 Wins | 4 Podiums | 2 Fastest race laps |

Audi market data in Japan 2015

- / Delivery volume: 29,400 units
- / Audi A3¹ best selling model



 Fuji Speedway
 Tokyo

¹ Please refer to the list on page 5 for the consumption and emission values

8 6H SHANGHAI, 06/11

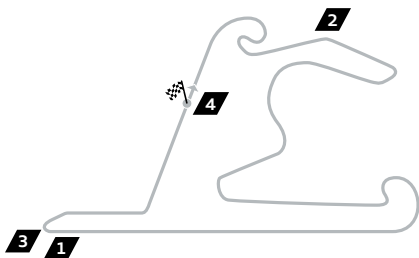

- 1** Top speed 299 km/h
- 2** Fastest corner 235 km/h
- 3** Slowest corner 56 km/h
- 4** Permitted hybrid energy 3.72 MJ

5.451 km Circuit length

approx. 190 km/h
Average speed

40 Gearshifts per lap

1m 42.719s
Lap record qualifying
Hartley/Webber (Porsche), 2015

1m 46.685s
Lap record race
André Lotterer (Audi), 2015

Audi's WEC track record in Shanghai

4 Races

0 1-2 & 1-2-3 finishes

0 Pole positions

1 Win

5 Podiums

2 Fastest race laps

Audi market data in China 2015

/ Delivery volume: 570,889 units

/ Production sites: Changchun,
Foshan



■ Shanghai International Circuit
■ Beijing

9 6H BAHRAIN, 19/11

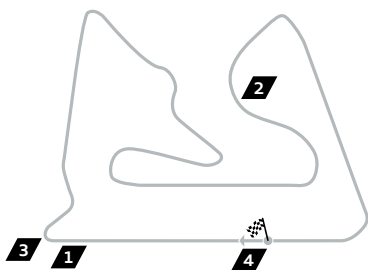

- 1** Top speed 285 km/h
- 2** Fastest corner 197 km/h
- 3** Slowest corner 59 km/h
- 4** Permitted hybrid energy 3.69 MJ

5.412 km Circuit length

approx. 195 km/h
Average speed

56 Gearshifts per lap

1m 39.736s
Lap record qualifying
Bernhard/Hartley (Porsche), 2015

1m 41.893s
Lap record race
Neel Jani (Porsche), 2015

Audi's WEC track record in Bahrain

- | | | |
|----------------|-----------------------------|---------------------------|
| 4 Races | 1 1-2 & 1-2-3 finish | 1 Pole position |
| 1 Win | 4 Podiums | 1 Fastest race lap |

Audi market data in the Middle East 2015

- / Delivery volume: 11,100 units
- / Audi Q7¹ best selling model



 Bahrain International Circuit
 Manama

¹ Please refer to the list on page 5 for the consumption and emission values

EVERY WINNER OF THE 24H LE MANS

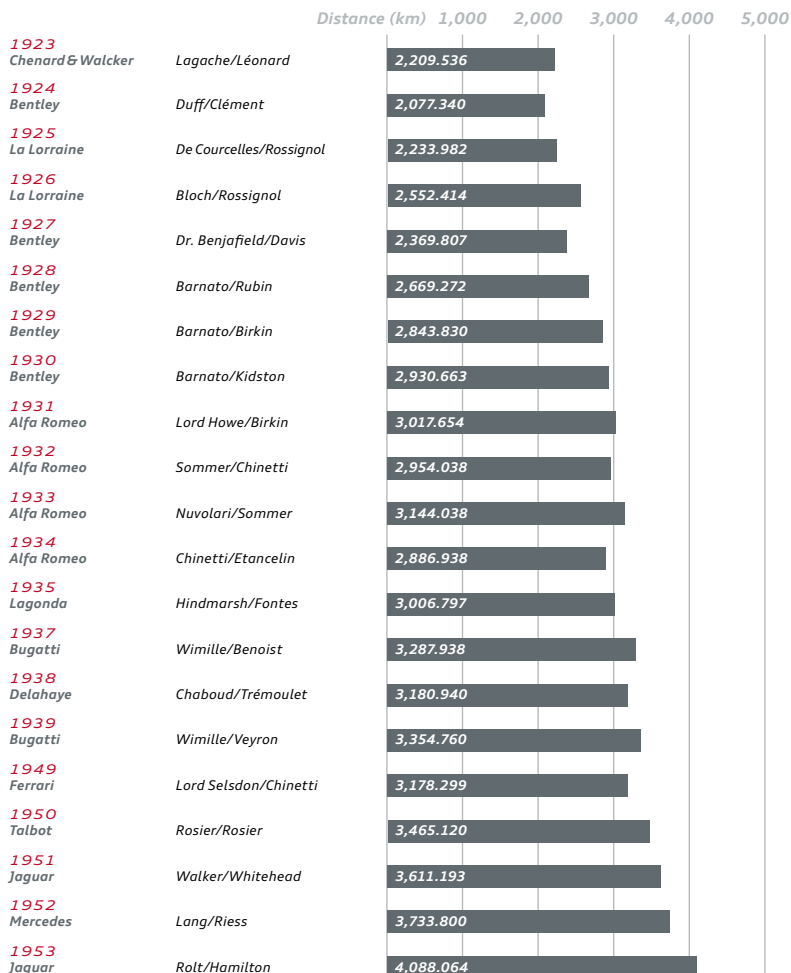

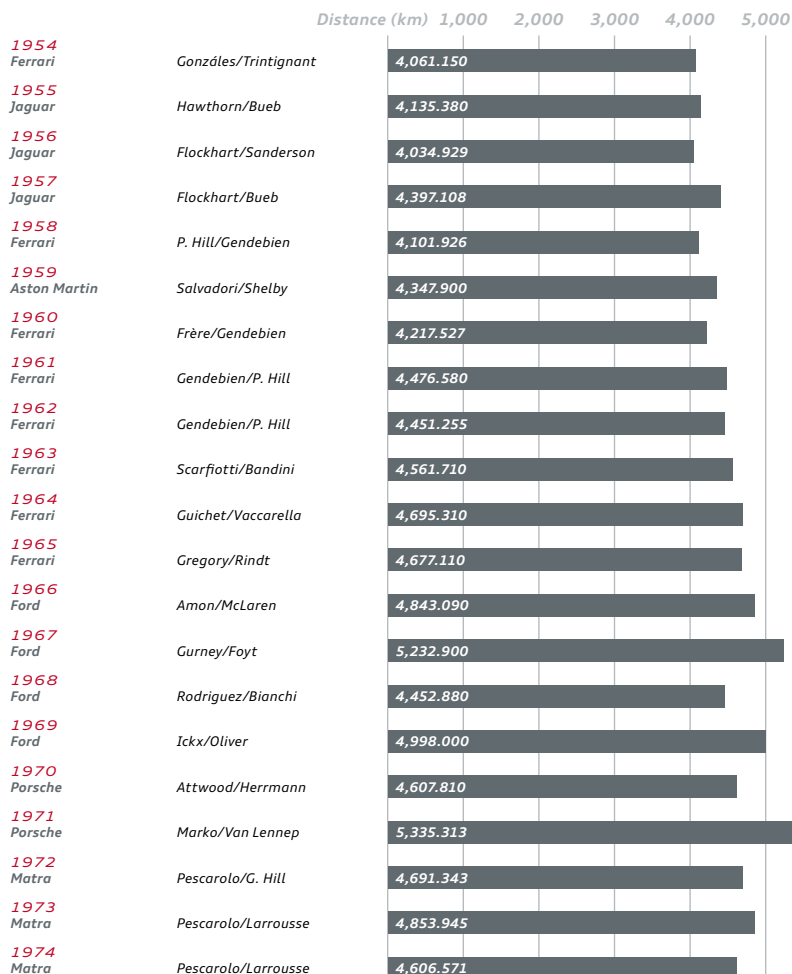

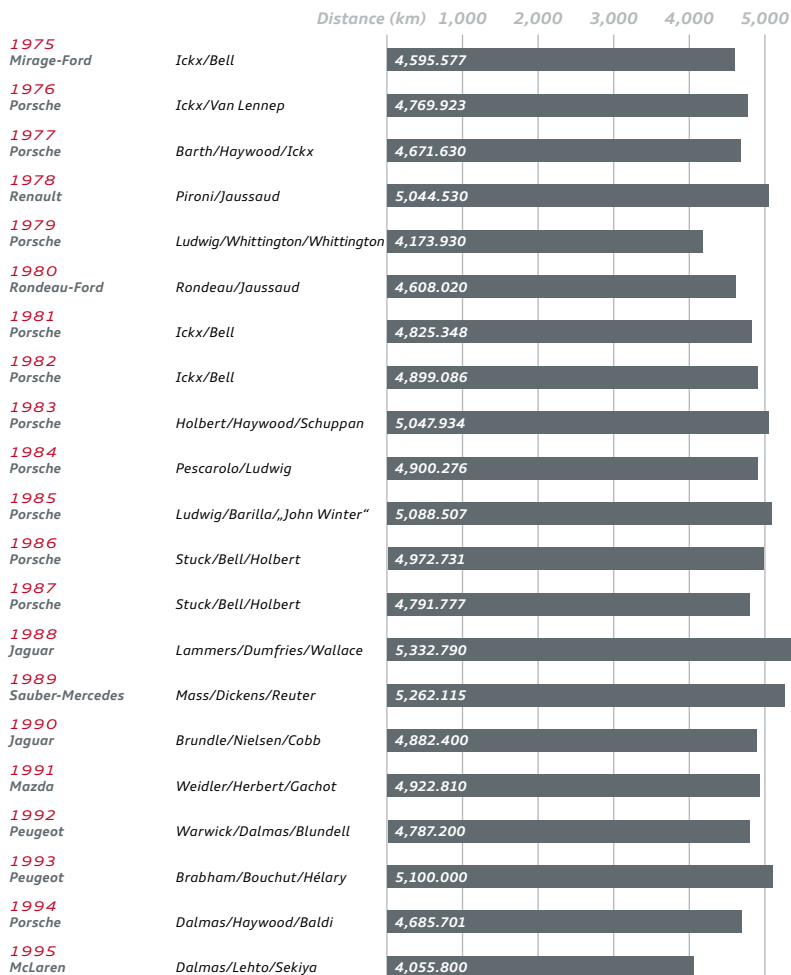

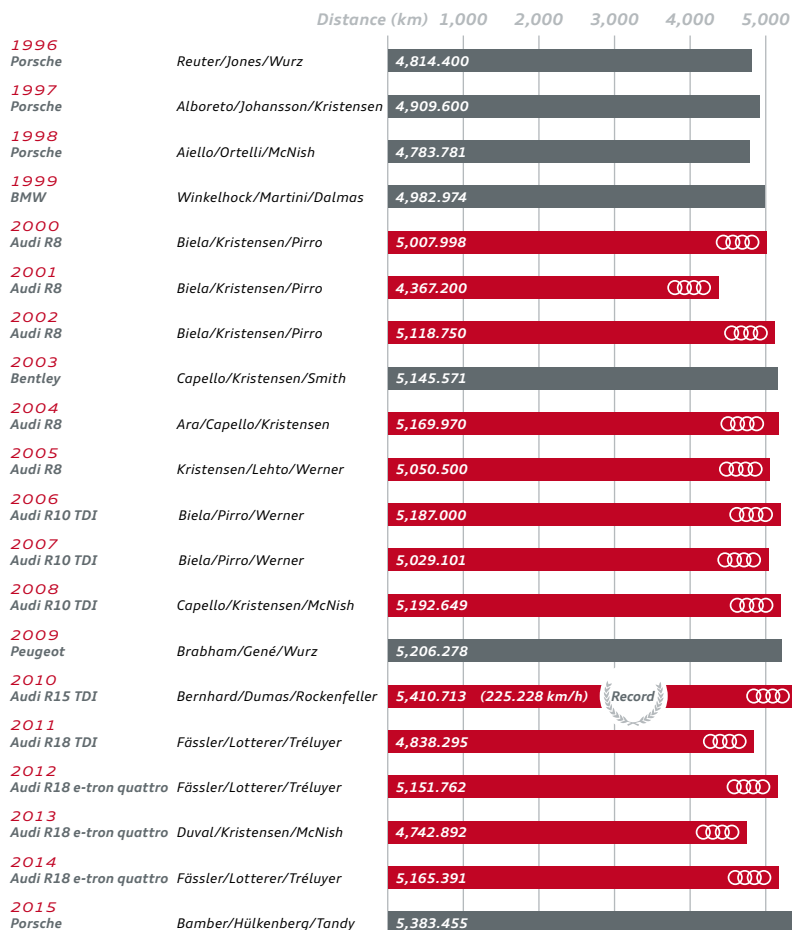

ALL 14 CIRCUIT VERSIONS EVER USED FOR THE 24H LE MANS

1929 16.340 km

1979 13.626 km
2007 13.629 km

1932 13.492 km
2002 13.650 km

1956 13.461 km
1987 13.535 km
1997 13.605 km
2006 13.650 km

1968 13.469 km

1972 13.640 km

1990 13.600 km

..... 1923 17.262 km

■ 2007-2016 13.629 km

● Modifications

1986 13.528 km

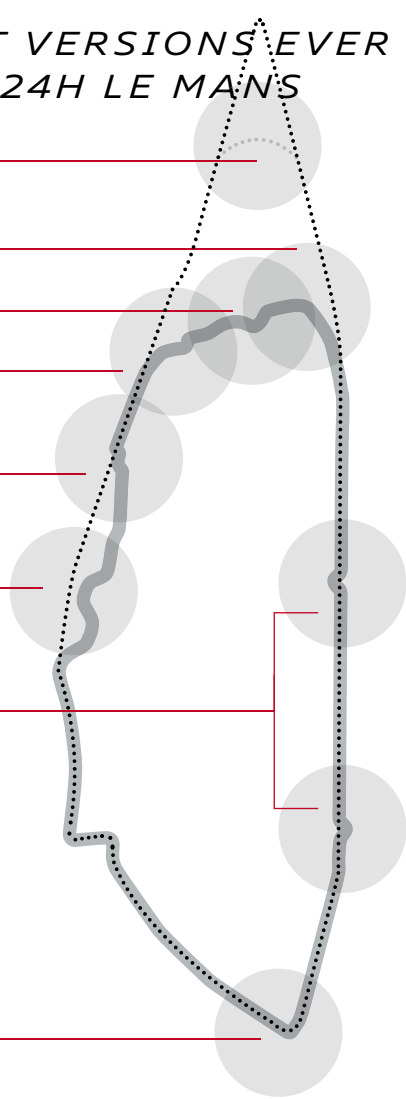

AUDI IN THE WEC (2012-2015)

10

Pole positions

2 Manufacturers' titles

48 Podiums

32
Races

15 Wins

19 Fastest laps

10
1-2 & 1-2-3 finishes

16
Drivers

2 Drivers' titles

1 Title defence
(2012,2013)

AUDI'S LMP TITLES AND GREAT ENDURANCE RACE VICTORIES

| |  Audi R8 |  Audi R10 TDI |  Audi R15 TDI |  Audi R18 TDI/ e-tron quattro ¹ |
|---------------------|--|---|---|---|
| WEC titles (2) | | | | ● ● 2012-2013 ¹ |
| ALMS titles (9) | ● ● ● ● ● ● ● ● ● 2000-2006 ¹ | ● ● ● 2006 ¹ -2008 | | |
| ELMS titles (3) | ● ● 2001, 2004 | ● 2008 | | |
| 24h Le Mans (13) | ● ● ● ● ● ● 2000-2002 2004-2005 | ● ● ● ● 2006-2008 | ● 2010 | ● ● ● ● ● 2011 ¹ 2012-2014 ¹ |
| 12h Sebring (11) | ● ● ● ● ● ● ● ● ● 2000-2005 | ● ● 2006-2007 | ● 2009 | ● ● 2012 ¹ 2013 ¹ |
| 'Petit Le Mans' (9) | ● ● ● ● ● ● ● ● ● 2000-2005 | ● ● ● ● 2006-2008 | | |

EVERY VICTORY FOR AUDI'S LMP RACE CARS 1999-2015

— Wins
— Races
% Winning ratio

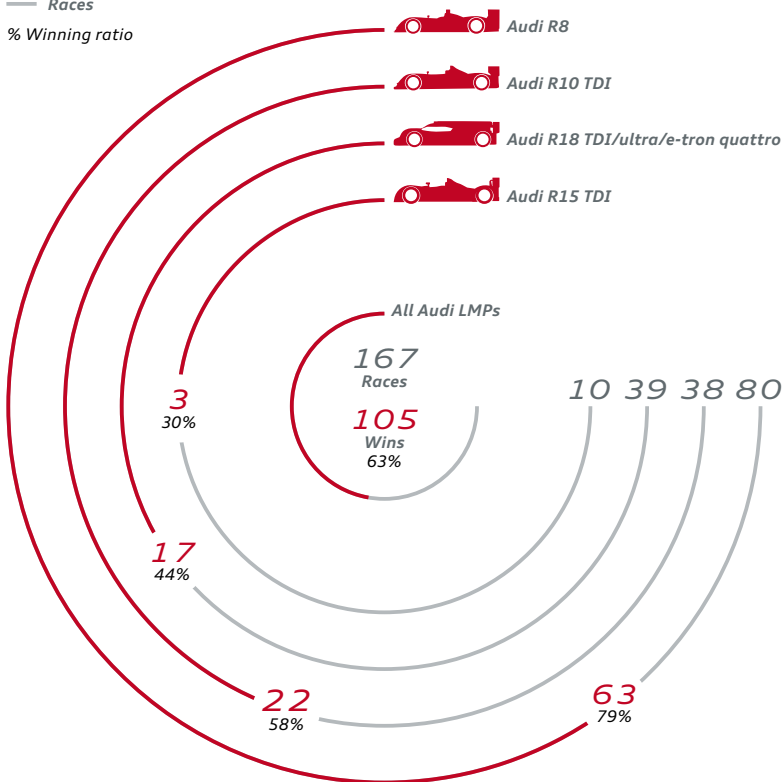

PARTNERS IN THE WEC



akrapovic.com



Technik fürs Leben

bosch.com



castrol.com



itk-engineering.com



mahle.com



michelin.com



Swiss Watches

oris.ch/en

WEC

Other partners



alpinestars.com



Das Wasser mit Stern

gerolsteiner.com



hofmuehl.de



oz-racing.de



| | | |
|-------------------|------------|-------------------|
| <i>DTM</i> | 70 | Technology |
| | 76 | Basics |
| | 80 | Key personnel |
| | 82 | Teams and drivers |
| | 83 | Teams |
| | 86 | Drivers |
| | 94 | Circuits |
| | 103 | Statistics |
| | 106 | Partners |

AUDI RS 5 DTM: SAFETY ELEMENTS

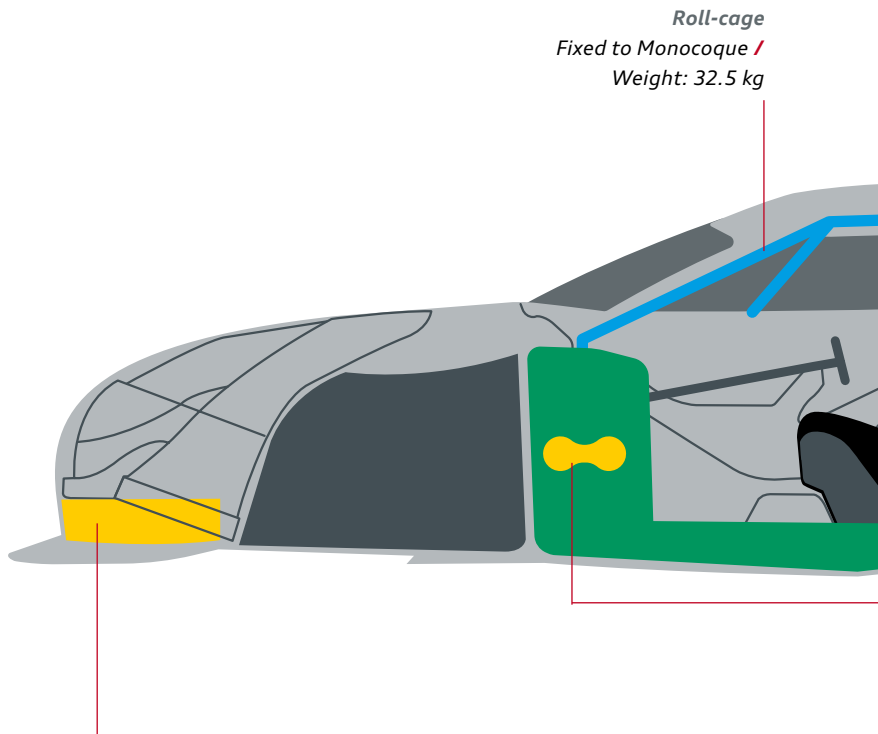

Roll-cage

Fixed to Monocoque /

Weight: 32.5 kg

Crash box, front

In a frontal impact at 54 km/h, the driver's chest must only be subject to a maximum load of 60 g

Monocoque

*Manufactured entirely from
Carbon / Weight: 126 kg /
120 liter fuel tank integrated*

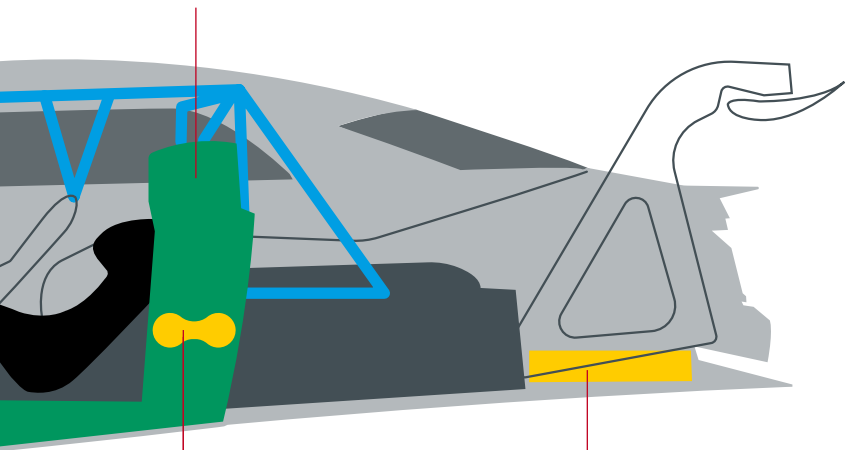

Crash boxes, lateral
*Complete side panel
must withstand a force of
360 kN in the side impact
test – this equals 36 tons*

Crash box, rear
*Length: 65 cm (as front) /
Must survive a crash test
against a solid wall at a
speed of about 50 km/h*

DRAG REDUCTION SYSTEM (DRS)

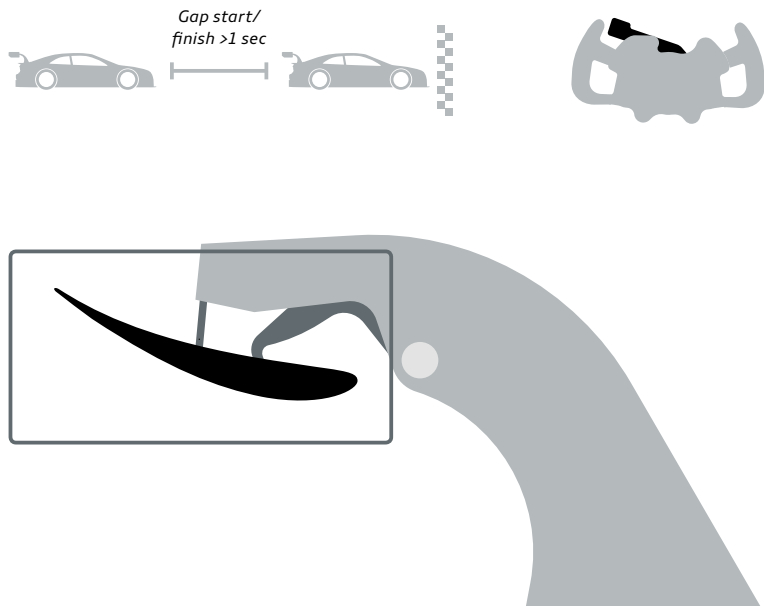

- / Movable rear wing in normal position
- / Greater air resistance generates downforce in the corners
- / Distance to car in front is measured at start/finish
- / If the interval is greater than one second: DRS disabled



Current position in race displayed by green LEDs in the rear side window



If a driver has used up his allocation of DRS activations, the position appears in red

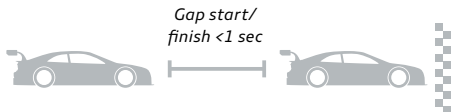

↗ 18° Rear wing angle reduction

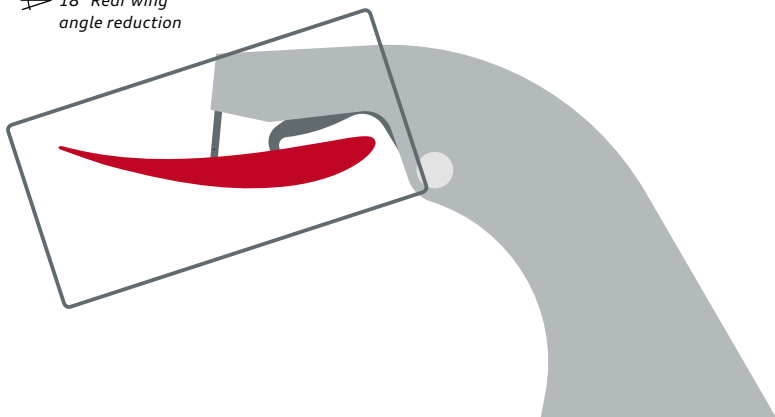

- / If the interval is less than one second: DRS enabled
- / DRS can be used up to three times during the following lap
- / Activations per race and driver are limited
- / The top speed increases on the straights owing to a reduction in drag

COCKPIT AUDI RS 5 DTM

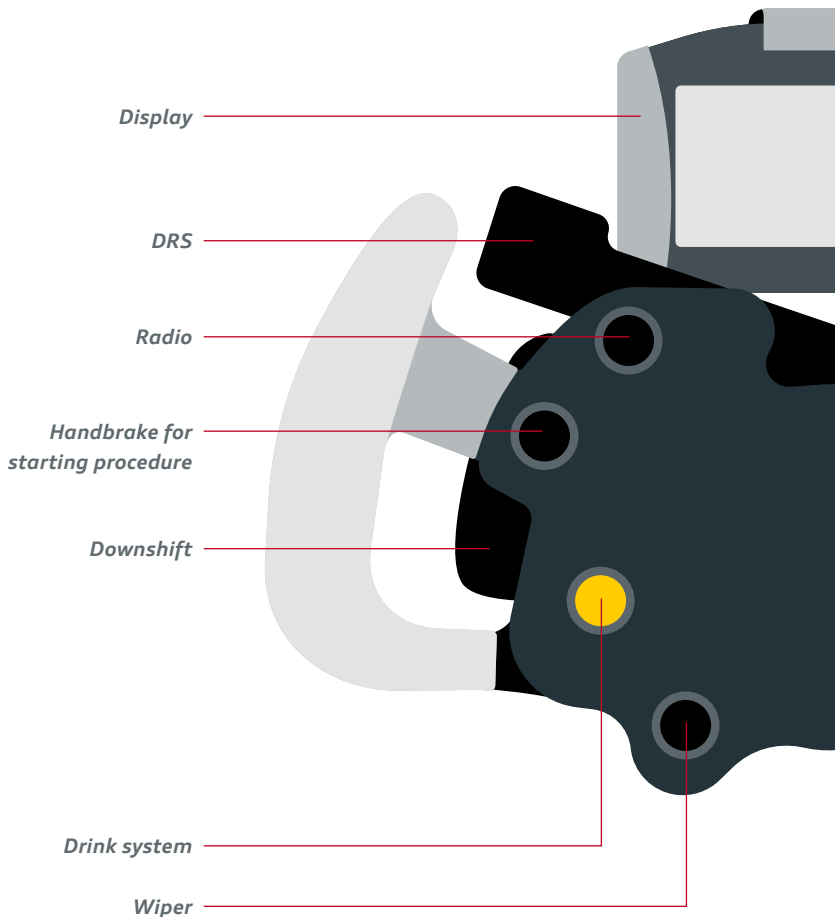

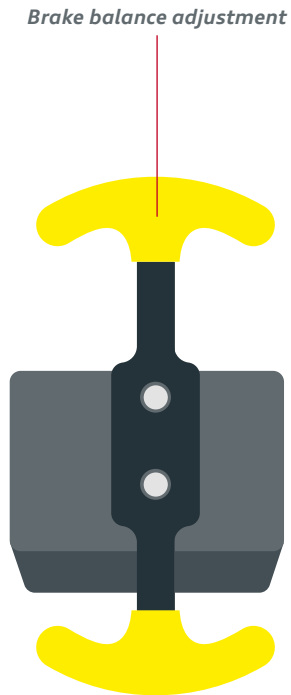
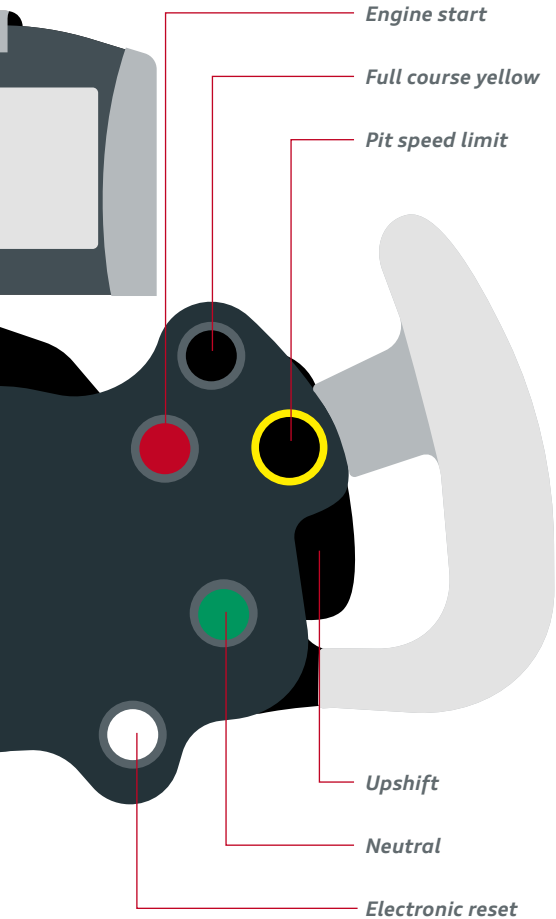

BASICS DTM

A race weekend schedule

Friday

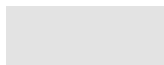

Free practice 1



30 min



Saturday



Free practice 2



30 min

Qualifying 1



20 min

Race 1



40 min



1 lap



Sunday



Free practice 3



30 min

Qualifying 2



20 min

Race 2



60 min



1 lap



Performance weight

$$S1 + S2 + S3 = \#1$$

In every qualifying session, the ideal lap time of every driver from each brand is determined from their fastest three sector times



Subject to the difference in time between a brand's best driver, a performance weight of up to 5 kg is added to or removed from the corresponding cars or the weight remains identical

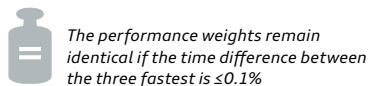

Points scoring system

| 1 st place | 2 nd place | 3 rd place | 4 th place | 5 th place | 6 th place | 7 th place | 8 th place | 9 th place | 10 th place |
|-----------------------|-----------------------|-----------------------|-----------------------|-----------------------|-----------------------|-----------------------|-----------------------|-----------------------|------------------------|
| ●●●●● | ●●●●● | ●●●●● | ●●●●● | ●●●●● | ●●●●● | ●●●●● | ●●●●● | ●● | ● |
| 25 | 18 | 15 | 12 | 10 | 8 | 6 | 4 | 2 | 1 |

Tires

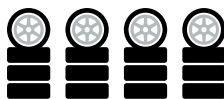

Four sets of slicks per car per weekend for qualifying and races

Titles



Driver



Team



Manufacturer

EVERY DTM YEAR

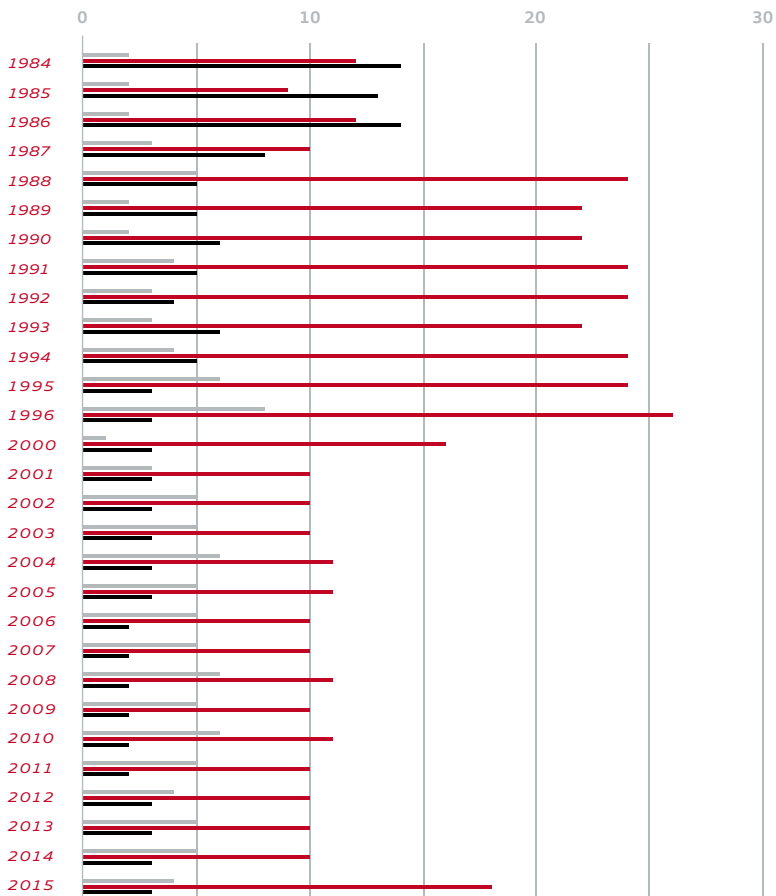

— Host countries

— Races

— Competing manufacturers

DTM

THE AVERAGE DTM CHAMPION ...

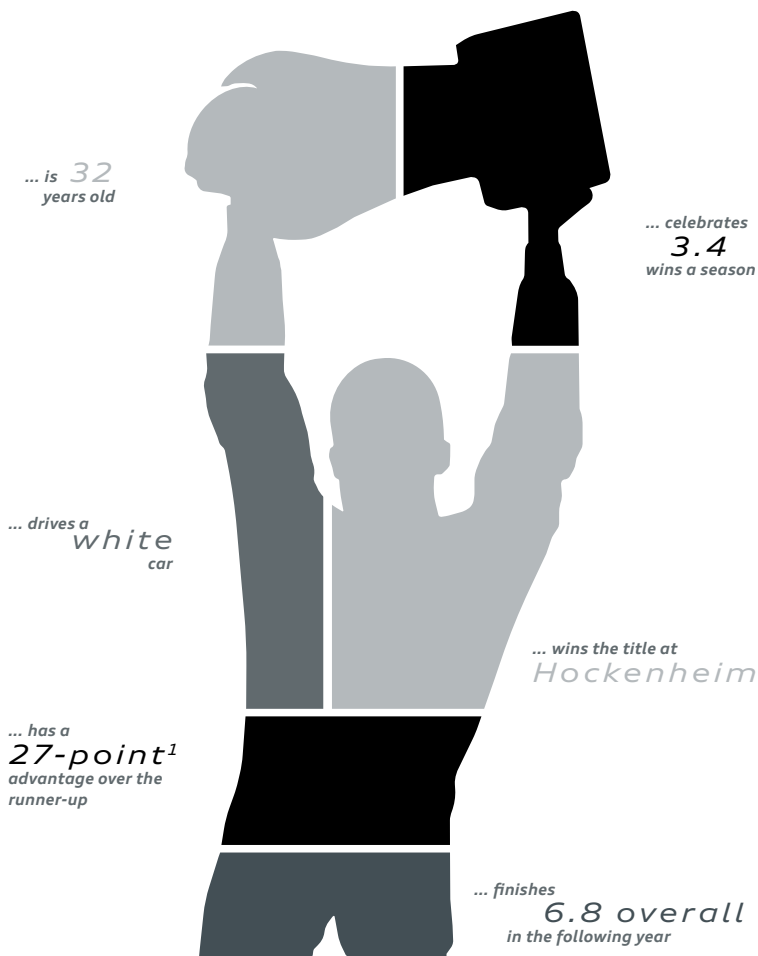

¹ Calculated using the current points scoring system

KEY PERSONNEL IN THE DTM PROGRAM



*Dieter Gass
Head of DTM*



*Stefan Gugger
Project Manager
Vehicle Development*



*Jürgen Hofbauer
Technical Coordinator*



*Dr. Andrea Milocco
Project Manager Engine*



*Florian Modlinger
Project Manager Test
& Technology*



*Volker Nossek
Project Manager Organization*



*Oliver Straube
Partnerships*

Audi Sport Team Abt Sportsline



Hans-Jürgen Abt
Team Director



Harry Unflath
Head of Marketing



Thomas Biermaier
Sport Director



Michael Seifert
Team Manager

Audi Sport Team Phoenix



Ernst Moser
Team Director



Dirk Theimann
Team Manager

Audi Sport Team Rosberg



Arno Zensen
Team Director



Francesco Nenci
Technical Director



Kimmo Liimatainen
Team Manager



Ramon Hämmerle
Team Coordinator

TEAMS AND DRIVERS

Audi Sport Team Abt Sportsline

 **EKS**
Mattias Ekström

Florian Modlinger
Car engineer



#5

Red Bull Audi RS 5 DTM

 **MOR**
Edoardo Mortara

Nicola Palarchi
Car engineer



#48

Castrol EDGE Audi RS 5 DTM

Audi Sport Team Abt

 **MOL**
Miguel Molina

Markus Michelberger
Car engineer



#17

Teufel Audi RS 5 DTM

 **MUE**
Nico Müller

Daniel Grunwald
Car engineer



#51

Playboy Audi RS 5 DTM

Audi Sport Team Phoenix

 **TSC**
Timo Scheider

Laurent Fedacou
Car engineer



#10

AUTO BILD MOTORSPORT Audi RS 5 DTM

 **ROC**
Mike Rockenfeller

Arnau Niubó
Car engineer



#99

Schaeffler Audi RS 5 DTM

Audi Sport Team Rosberg

 **TAM**
Adrien Tambay

Karl Jennings
Car engineer



#27

Speedweek.com Audi RS 5 DTM

 **GRE**
Jamie Green

Erich Baumgärtner
Car engineer



#53

Hoffmann Group Audi RS 5 DTM

DTM

AUDI SPORT TEAM ABT SPORTSLINE

1991
Founded

Since 1996
Partner of Audi

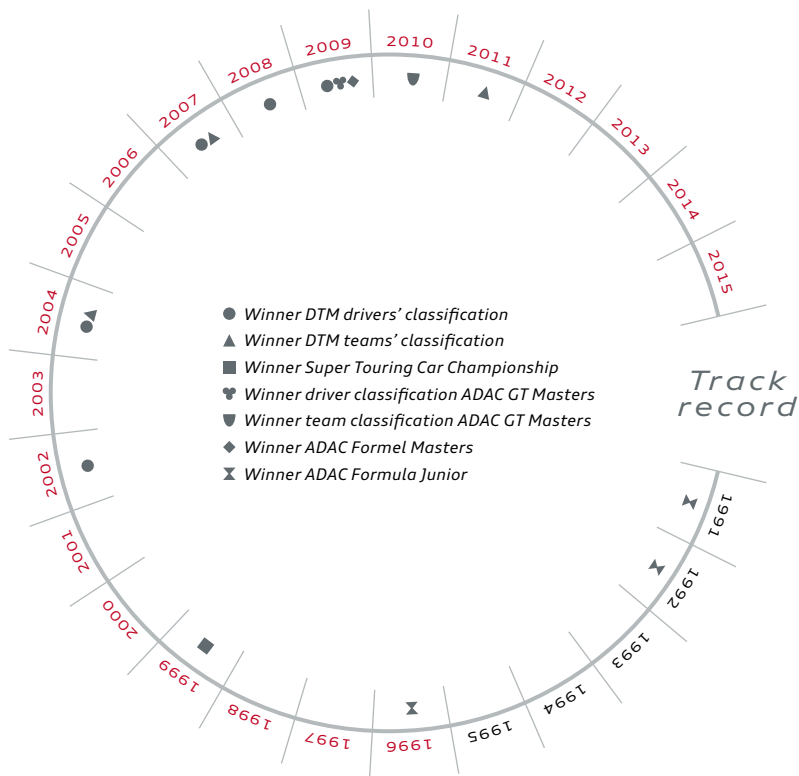

AUDI SPORT TEAM PHOENIX

1999
Founded

Since 2006
Partner of Audi

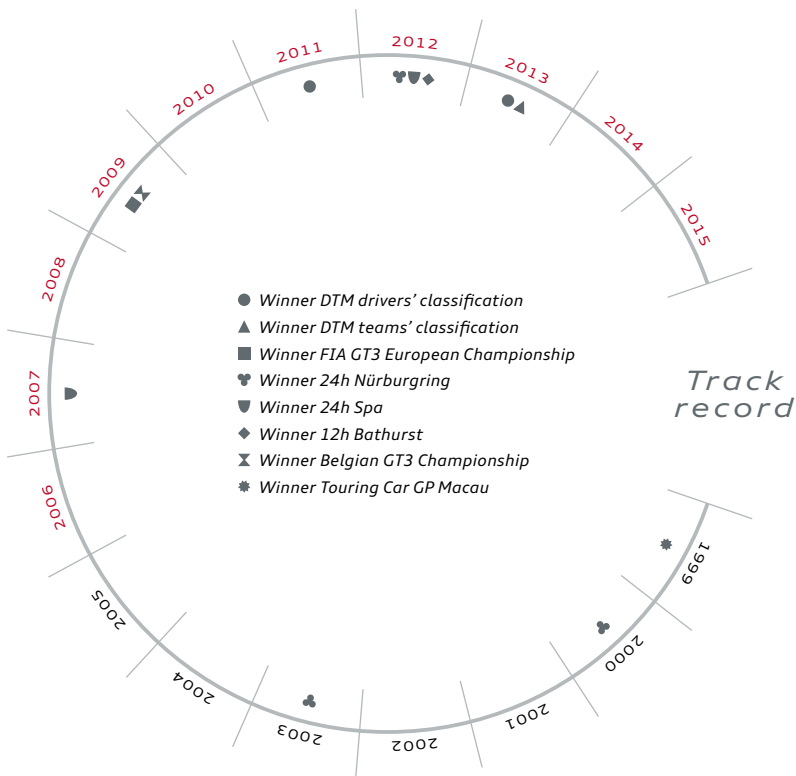

DTM

AUDI SPORT TEAM ROSBERG

1994
Founded

Since 2006
Partner of Audi

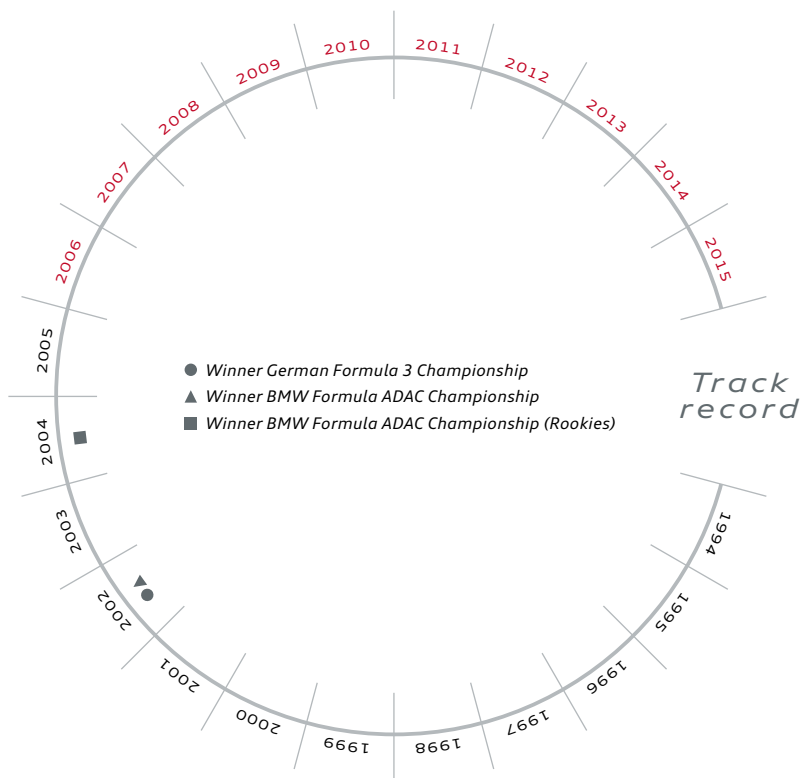



#5 MATTIAS EKSTRÖM



* July 14, 1978, Falun (S)
▲ Ellmau (A)

Hobbies



Marital status

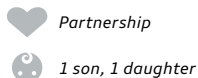

Statistics

| | DTM |
|--------------------|------------------------------|
| Best table ranking | 1st 2x |
| Number of races | 161 |
| Best grid position | 1st 20x |
| Best result | 1st 21x |

Career highlights

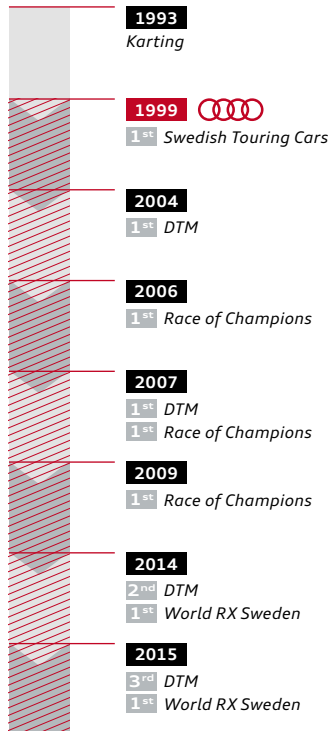

- mattiasekstrom.com
- [mattiasekstrom.racing](https://www.facebook.com/mattiasekstrom.racing)
- [@mattiasekstroem](https://twitter.com/mattiasekstroem)
- [mattiasekstromracing](https://www.instagram.com/mattiasekstromracing)



#53 JAMIE GREEN



1.78 m

* June 14, 1982, Leicester (GB)
▲ Monaco (MC)

Hobbies

 Soccer





 Golf

Marital status

 Married

 2 sons

Statistics

| | DTM |
|--|-------------------------|
|  Best table ranking | 2 nd 2015 |
|  Number of races | 121 |
|  Best grid position | 1 st 9x |
|  Best result | 1 st 11x |

Career highlights

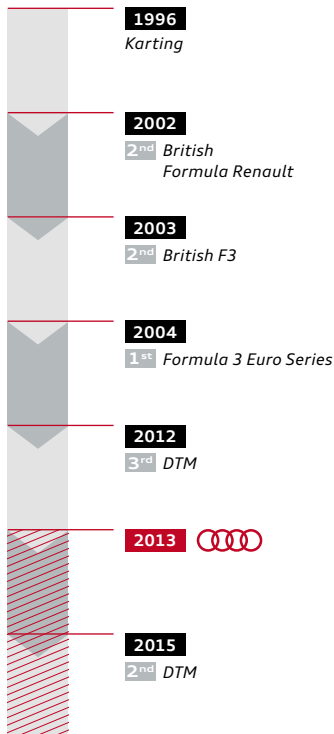

 jamiengreenracing.com

 @jamiengreen_



#17 MIGUEL MOLINA



1.75 m

* February 17, 1989, Barcelona (E)
▲ Lloret de Mar (E)

Hobby







Slotcars

Marital status



Partnership

Statistics

| | DTM |
|---|--------------------------------|
|  Best table ranking | 10th 2010 |
|  Number of races | 69 |
|  Best grid position | 1st 5x |
|  Best result | 1st 2015 |

Career highlights

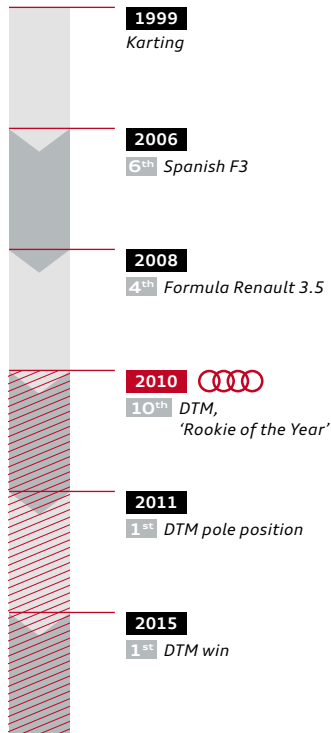

 miguelmolina.net

 [miguelmolina.racing](https://www.facebook.com/miguelmolina.racing)

 [@miguelmolina2](https://twitter.com/miguelmolina2)

 [miguelmolina2](https://www.instagram.com/miguelmolina2)

DTM



#48 EDOARDO MORTARA



1.82 m

* January 12, 1987, Geneva (CH)

▲ Geneva (CH)

Hobbies



Skiing



Wakeboarding

Marital status



Married

Statistics

| | |
|--------------------|-------------------------------|
| | DTM |
| Best table ranking | 4th 2015 |
| Number of races | 58 |
| Best grid position | 1st 2012 |
| Best result | 1st 3x |

Career highlights

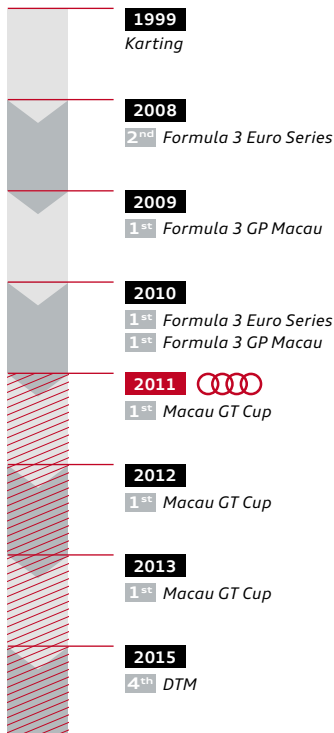

 [edoardomortara.com](https://twitter.com/edoardomortara)

 [edomortararacing](https://www.facebook.com/edomortararacing)

 [@edomortara](https://www.instagram.com/edomortara)

 [edomortara](https://www.youtube.com/edomortara)



#51 NICO MÜLLER



* February 25, 1992, Thun (CH)
▲ Bern (CH)

Hobbies



Karting







Cycling

Marital status



Single

Statistics

| | DTM |
|---|--------------------------------|
|  Best table ranking | 19th 2014 |
|  Number of races | 28 |
|  Best grid position | 3rd 2014 |
|  Best result | 5th 2x |

Career highlights

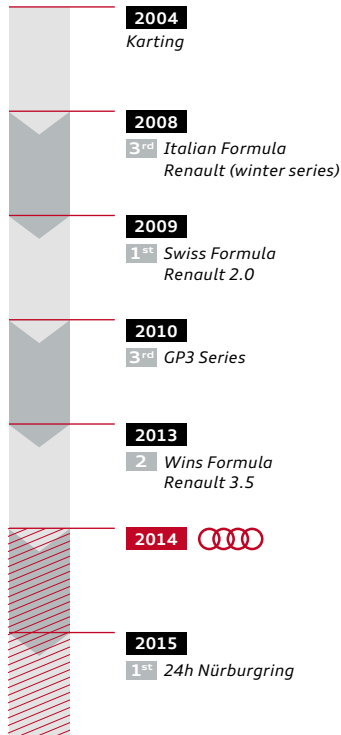

 nicomueller.ch

 [nicomuellerofficial](https://www.facebook.com/nicomuellerofficial)

 [@nico_mueller](https://twitter.com/nico_mueller)

 [nico.mueller51](https://www.instagram.com/nico.mueller51)



#99 MIKE ROCKENFELLER



* October 31, 1983, Neuwied (D)
▲ Landschlacht (CH)

Hobbies

 Historic cars





 Cycling

Marital status

 Married

 1 son

Statistics

| | DTM |
|--|-------------------------------|
|  Best table ranking | 1st 2013 |
|  Number of races | 99 |
|  Best grid position | 1st 6x |
|  Best result | 1st 4x |

Career highlights

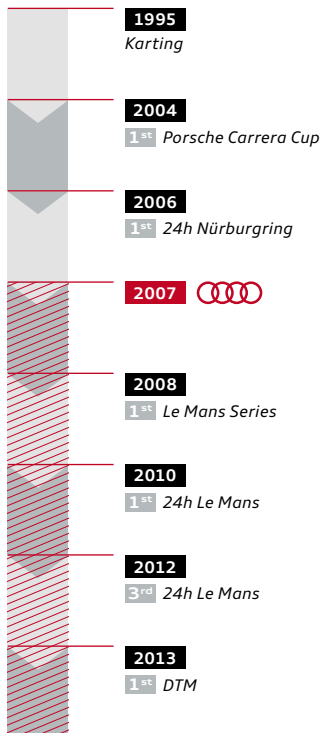

 [mike-rockenfeller.de](#)

 [mikerockenfeller](#)

 [@m_rockenfeller](#)

 [mike_rockenfeller](#)



#10 TIMO SCHEIDER



1.78 m

* November 10, 1978, Lahnstein (D)
▲ Lochau (A)

Hobbies



Family



Karting

Marital status







Engaged





1 son

Statistics

| | DTM |
|---|------------------------------|
|  Best table ranking | 1st 2x |
|  Number of races | 163 |
|  Best grid position | 1st 11x |
|  Best result | 1st 7x |

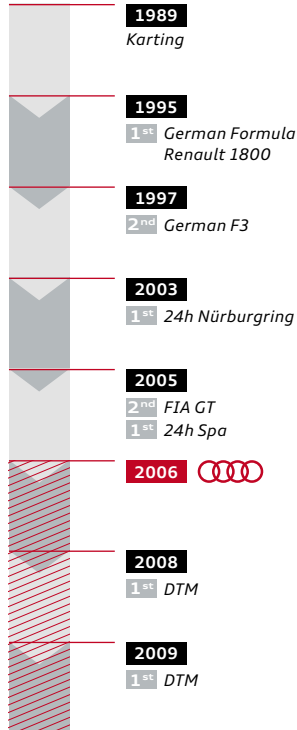
Career highlights



 timoscheider.de

 [scheider](https://www.facebook.com/scheider)

 [@scheidertimo](https://twitter.com/scheidertimo)

 [timoscheider](https://www.instagram.com/timoscheider)





DTM

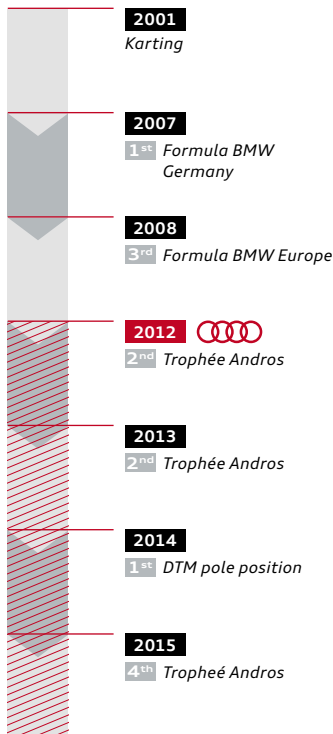

#27 ADRIEN TAMBAY

Career highlights



-  adrientambay.com
-  [adrientambayofficial](https://www.facebook.com/adrientambayofficial)
-  [@tambayracing](https://twitter.com/tambayracing)
-  [adrientambay](https://www.instagram.com/adrientambay)



 1.81 m

* February 25, 1991, Paris (F)
▲ London (GB)

Hobbies





 Family

 Fitness

Marital status

 Single

Statistics

| | DTM |
|--|--------------------------|
|  Best table ranking | 10 th 2012 |
|  Number of races | 48 |
|  Best grid position | 1 st 2014 |
|  Best result | 2 nd 2012 |

1 HOCKENHEIM, 07-08/05

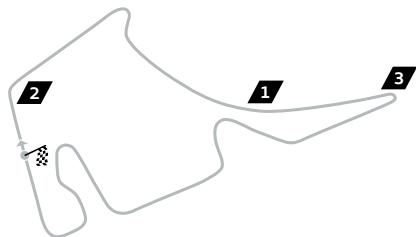

4.574 km Track length

approx. 180 km/h
Average speed

30 Gearshifts per lap

1m 32.244s
Lap record qualifying
Mattias Ekström (Audi), 2008

1m 32.532s
Lap record race
Martin Tomczyk (BMW), 2014

- 1** Top speed 255 km/h
- 2** Fastest corner 185 km/h
- 3** Slowest corner 55 km/h

Audi's DTM track record at Hockenheim opener¹

19 Events
37 overall including finale

24 Races
46 overall including finale

6 Wins
14 overall including finale

5 1-2 & 1-2-3 finishes
12 overall including finale

23 Podiums
55 overall including finale

9 Pole positions
20 overall including finale

4 Fastest race laps
10 overall including finale

Audi Zentrum close by

Audi Zentrum Heidelberg
Hebelstraße 12
D-69115 Heidelberg
Phone +49 6221 535200



-  Hockenheimring
-  Audi Zentrum (distance 21 km)

2 SPIELBERG, 21-22/05

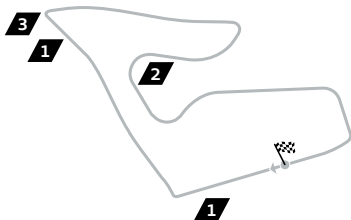

- 1** Top speed 240 km/h
- 2** Fastest corner 175 km/h
- 3** Slowest corner 65 km/h

Audi's DTM track record in Spielberg

- 8** Events
- 9** Races
- 4** Wins
- 0** 1-2 & 1-2-3 finishes
- 7** Podiums
- 5** Pole positions
- 4** Fastest race laps

4.326 km Track length

approx. 185 km/h
Average speed

30 Gearshifts per lap



1m 24.588s
Lap record qualifying
Bruno Spengler (BMW), 2013

1m 25.266s
Lap record race
Mike Rockenfeller (Audi), 2014

Audi Zentrum close by

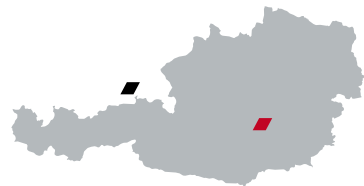
Audi Zentrum Rosenheim Ludwig
Kriechbaum GmbH
Innstraße 63
D-83022 Rosenheim
Phone +49 8031 389370



-  Red Bull Ring Spielberg
-  Audi Zentrum (distance 334 km)

3 LAUSITZRING, 04-05/06

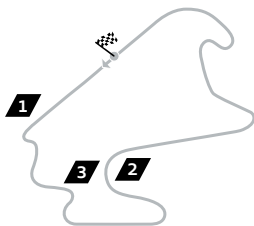

- 1** Top speed 245 km/h
- 2** Fastest corner 165 km/h
- 3** Slowest corner 80 km/h

3.478 km Track length

approx. 160 km/h
Average speed

25 Gearshifts per lap

1m 17.386s
Lap record qualifying
Jamie Green (Audi), 2015

1m 18.268s
Lap record race
Mike Rockenfeller (Audi), 2013

Audi's DTM track record at the Lausitzring

- 17** Events
- 17** Races
- 4** Wins
- 3** 1-2 & 1-2-3 finishes
- 21** Podiums
- 4** Pole positions
- 8** Fastest race laps

Audi Zentrum close by

Audi Zentrum Dresden
Hamburger Straße 28
D-01067 Dresden
Phone +49 351 4920100



-  EuroSpeedway Lausitz
-  Audi Zentrum (distance 65 km)

4 NORISRING, 25-26/06

2.300 km Track length

approx. 175 km/h
Average speed

22 Gearshifts per lap

47.785s
Lap record qualifying
Bruno Spengler (Mercedes-Benz), 2008

48.178s
Lap record race
Robert Wickens (Mercedes-Benz), 2015

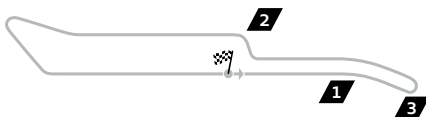

- 1** Top speed 250 km/h
- 2** Fastest corner 110 km/h
- 3** Slowest corner 55 km/h

Audi's DTM track record at the Norisring

18 Events

22 Races

3 Wins

1 1-2 & 1-2-3 finish

15 Podiums

3 Pole positions

6 Fastest race laps

Audi Zentrum close by

Audi Zentrum Nürnberg-Marienberg GmbH
Marienbergstraße 88
D-90411 Nuremberg
Phone +49 911 54030



-  Norisring
-  Audi Zentrum (distance 9 km)

5 ZANDVOORT, 16-17/07

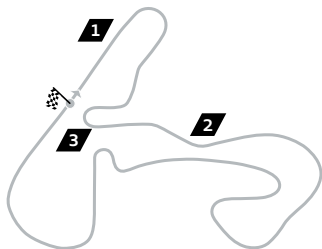

- 1** Top speed 250 km/h
- 2** Fastest corner 190 km/h
- 3** Slowest corner 85 km/h

Audi's DTM track record at Zandvoort

- 15** Events
- 16** Races
- 8** Wins
- 4** 1-2 & 1-2-3 finishes
- 25** Podiums
- 8** Pole positions
- 6** Fastest race laps

4.307 km Track length

approx. 170 km/h
Average speed

25 Gearshifts per lap



1m 30.449s
Lap record qualifying
Pascal Wehrlein (Mercedes-Benz), 2014

1m 32.296s
Lap record race
Marco Wittmann (BMW), 2013

Audi Zentrum close by

Audi Centrum Amsterdam
Klokkenbergweg 19
1101 AK Amsterdam Zuidoost
The Netherlands
Phone +31 20 5646464



-  Circuit Park Zandvoort
-  Audi Zentrum (distance 37 km)

6 MOSCOW, 20-21/08

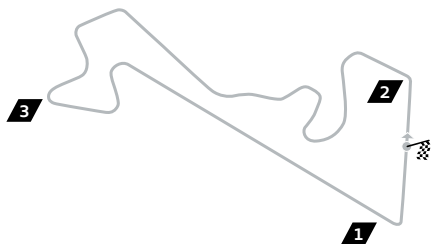

- 1** Top speed 250 km/h
- 2** Fastest corner 180 km/h
- 3** Slowest corner 70 km/h

3.931 km Track length

approx. 160 km/h
Average speed

26 Gearshifts per lap

1m 28.523s
Lap record qualifying
Maxime Martin (BMW), 2014

1m 28.305s
Lap record race
Miguel Molina (Audi), 2014

Audi's DTM track record in Moscow

- 3** Events
- 4** Races
- 2** Wins
- 1** 1-2 & 1-2-3 finish
- 5** Podiums
- 2** Pole positions
- 3** Fastest race laps

Audi Zentrum close by

Audi Centr Moskva
Horoshevskoe Shosse, 70, Korpus 1
123007 Moskva
Russia
Phone +7 495 7979090



-  Moscow Raceway
-  Audi Zentrum (distance 98 km)

7 NÜRBURGRING, 10-11/09

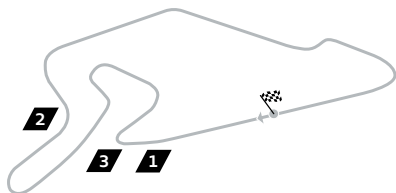

- 1** Top speed 245 km/h
- 2** Fastest corner 145 km/h
- 3** Slowest corner 70 km/h

3.629 km Track length

approx. 160 km/h
Average speed

23 Gearshifts per lap

1m 21.732s

Lap record qualifying
Miguel Molina (Audi), 2015

1m 23.175s

Lap record race
Marco Wittmann (BMW), 2014



Audi's DTM track record at the Nürburgring

- 26** Events
- 36** Races
- 10** Wins
- 3** 1-2 & 1-2-3 finishes
- 25** Podiums
- 9** Pole positions
- 5** Fastest race laps

Audi Zentrum close by

Audi Zentrum Koblenz GmbH
Friedrich-Mohr-Straße 4
D-56070 Koblenz
Phone +49 261 808040



-  Nürburgring
-  Audi Zentrum (distance 56 km)

8 BUDAPEST, 24-25/09

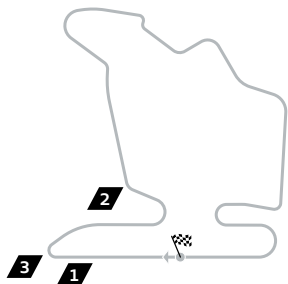

- 1** Top speed 240 km/h
- 2** Fastest corner 175 km/h
- 3** Slowest corner 80 km/h

Audi's DTM track record at Budapest

- 1** Event
- 1** Race
- 0** Wins
- 0** 1-2 & 1-2-3 finishes
- 1** Podium
- 0** Pole positions
- 1** Fastest race lap

4.381 km Track length

approx. 160 km/h
Average speed

28 Gearshifts per lap

1m 36.518s
Lap record qualifying
Marco Wittmann (BMW), 2014

1m 37.556s
Lap record race
Nico Müller (Audi), 2014

Audi Zentrum close by

Óbudai Autójavító Kft
Mozaik utca 1-3
1033 Budapest
Hungary
Phone +36 1 2500222



-  Hungaroring
-  Audi Zentrum (distance 24 km)

9 HOCKENHEIM, 15-16/10

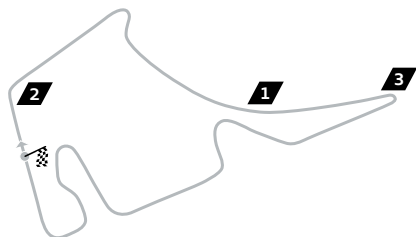

4.574 km Track length

approx. 180 km/h
Average speed

30 Gearshifts per lap

1m 32.244s
Lap record qualifying
Mattias Ekström (Audi), 2008

1m 32.532s
Lap record race
Martin Tomczyk (BMW), 2014

- 1** Top speed 255 km/h
- 2** Fastest corner 190 km/h
- 3** Slowest corner 55 km/h

Audi's DTM track record at the Hockenheim finale¹

18 Events
37 overall including opener

22 Races
46 overall including opener

8 Wins
14 overall including opener

7 1-2 & 1-2-3 finishes
12 overall including opener

32 Podiums
55 overall including opener

11 Pole positions
20 overall including opener

6 Fastest race laps
10 overall including opener

Audi Zentrum close by

Audi Zentrum Heidelberg
Hebelstraße 12
D-69115 Heidelberg
Phone +49 6221 535200



-  Hockenheimring
-  Audi Zentrum (distance 21 km)

¹Hockenheim did not host the season finale in 1991 and 2010

AUDI IN THE DTM

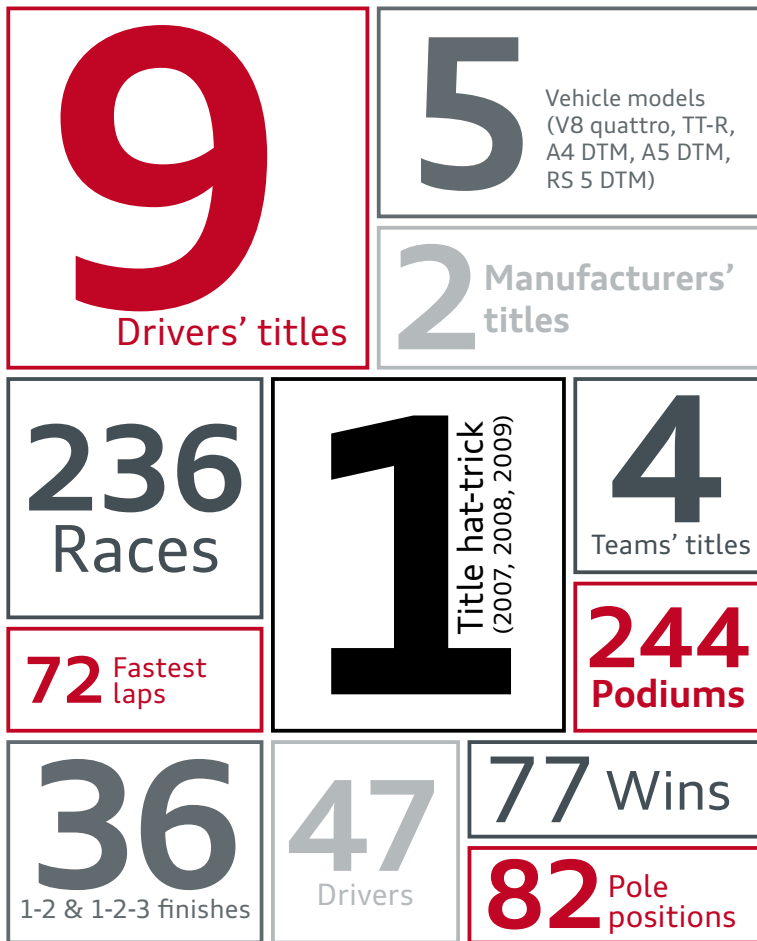

BEST AUDI DRIVERS EACH SEASON

1ST place

1990
Hans-Joachim Stuck

1991
Frank Biela

2002
Laurent Aiello

2004
Mattias Ekström

2007
Mattias Ekström

2008
Timo Scheider

2ND place

2005
Mattias Ekström

2009
Timo Scheider

2014
Mattias Ekström

2011
Martin Tomczyk

2015
Jamie Green

2013
Mike Rockenfeller

3RD place

2006
Tom Kristensen

2003
Mattias Ekström 4th place

2012
Mike Rockenfeller 4th place

1992
Frank Biela 15th place

2010
Timo Scheider 4th place

2001
Laurent Aiello 5th place

2000
Laurent Aiello 16th place

WINNING RATIO BY CAR

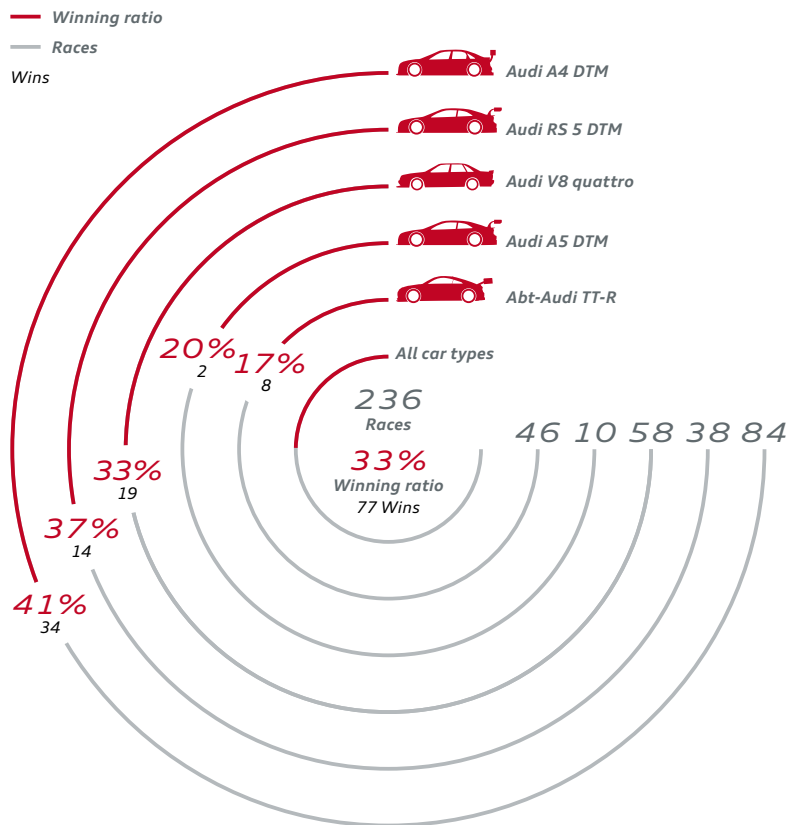

PARTNERS IN THE DTM



akrapovic.com



aral.de



audi-motorsport.com



autobild.de/motorsport



castrol.com



cisco.com



hoffmann-group.com



oris.ch/en



playboy.com



redbull.com



schaeffler.com



speedweek.com



teufel.de

DTM

Other partners



alpinestars.com

Audi
Top Service®

audi.com



eibach.de



Das Wasser mit Stern

gerolsteiner.com



hofmuehl.de



man.eu



oz-racing.de

DIE  **WELT**

welt.de



GT RACING

- 110** Technology
- 114** Global appeal
- 116** Contacts
- 117** Audi R8 LMS Cup
- 118** Audi race experience
- 119** Audi Sport racing academy
- 120** Statistics
- 123** Partners

NEW AUDI R8 LMS

Technical progress

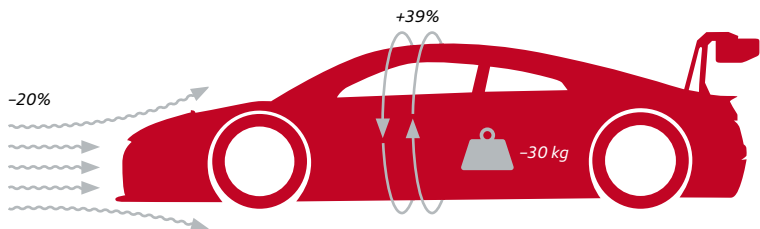

- / Aerodynamic drag reduced by 20 per cent
- / Torsional stiffness of chassis increased by 39 per cent
- / Chassis 30 kg lighter

Robust V10 engine

After **10,000 km** running: first service



After **20,000 km** running: first rebuild

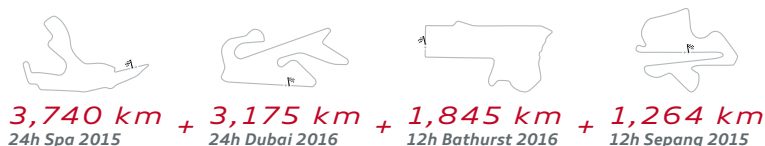

GT RACING

¹ Distance at all of the seven races measured to the best placed Audi

Successful model Audi R8 LMS

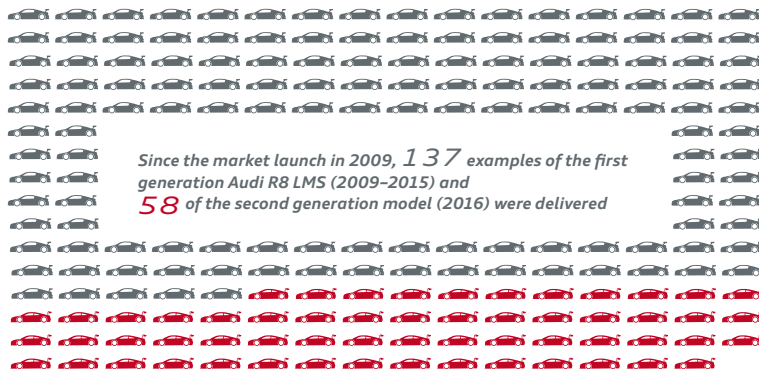

Spare parts warehouse Audi Sport customer racing



11,213
Individual parts

Parts deliveries 2015

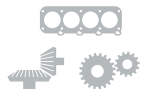

133,000
Parts



1,618
Deliveries



62
Customers on 4 continents

COCKPIT AUDI R8 LMS

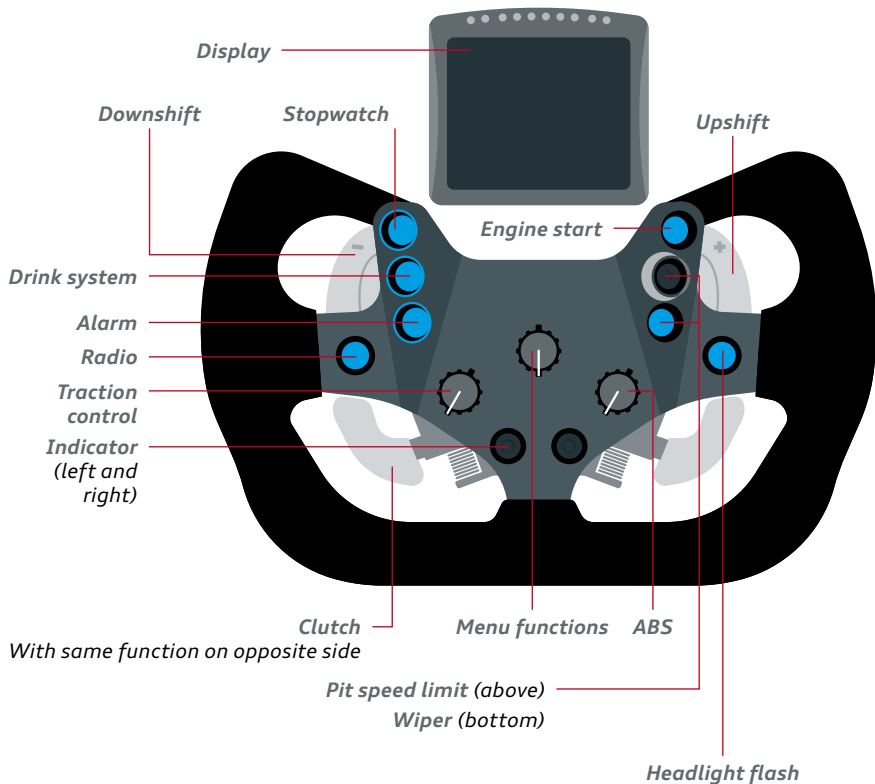

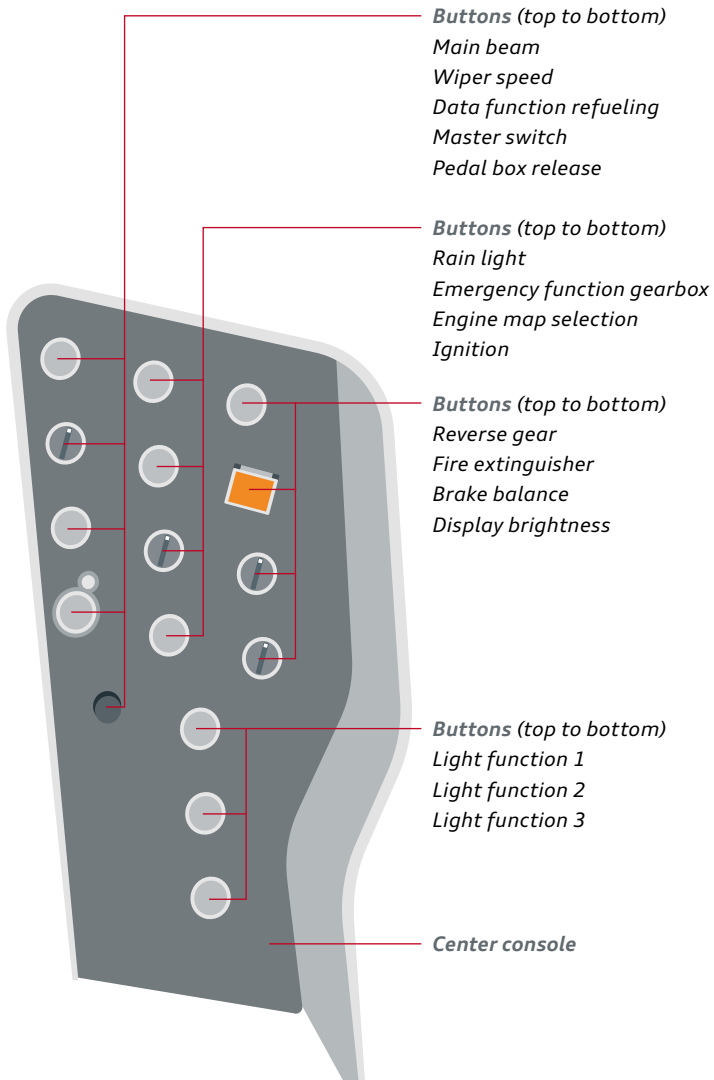

THE AUDI R8 LMS WORLDWIDE

Endurance races

12h Bathurst

bathurst12hour.com.au

24h Daytona

daytonainternationalspeedway.com

24h Dubai

24hseries.com

24h Nürburgring

24h-rennen.de

12h Sebring

sebringraceway.com

12h Sepang

sepang12hours.com

24h Spa

24hoursofspa.com

25h Thunderhill

nasa25hour.com

America

IMSA WeatherTech SportsCar Championship

imsa.com

Pirelli World Challenge

world-challenge.com

Asia

Asian Le Mans Series

asianlemansseries.com

Audi R8 LMS Cup

audi-motorsport-asia.com

GT Asia

gtasiaseries.com

Super GT

supergt.net/en

Super Taikyu

supertaikyu.com

Thailand Super Series

thailandsuperseries.net

Australia

Australian GT Championship

australiangt.com.au

GT RACING

Europe

ADAC GT Masters

adac-gt-masters.de

Campionato Italiano GT

acisportitalia.it/CIGT

GT Cup Championship

gtcup.co.uk

GT Tour

gt-tour.fr

Spezial Tourenwagen Trophy

spezial-tourenwagen-trophy.de

VLN Langstrecken-Meisterschaft

vln.de

British GT Championship

britishgt.com

DMV GTC

dmv-gtc.de

GT Sports Club

gtsportsclub.com

International GT Open

gtopen.net

V de V Challenge GT

vdev.fr

International

Blancpain GT Series

blancpain-gt-series.com

International Endurance Series

24hseries.com

Intercontinental GT Challenge

sro-motorsports.com/series/details/Intercontinental-GT-Challenge

CONTACTS AUDI SPORT CUSTOMER RACING



Dietmar Ponticelli
Project Manager
customer racing



Philipp Mondelaers
Project Manager
Audi Sport TT Cup



Chris Reinke
Head of
Audi Sport
customer racing



Dirk Spohr
Head of Customer
Management



Hendrik Többe
Sales/Marketing

Audi Sport customer racing

Asia



Rene Koneberg
Head of Audi Sport
customer racing Asia



Erin Keating
Product Strategy,
Launch and Audi Sport



Tristan Herbert
Manager Motorsport &
Customer Racing
Audi Sport customer racing
North America

Audi race experience



Klaus Demel
Head of
Audi driving experience



Rainer Kammerbauer
Project Manager of
Audi race experience



Josef Haider
Sporting Director
Audi race experience

GT RACING

AUDI R8 LMS CUP

Event calendar

- 1** 21-22/05 Shanghai (China)
- 2** 23-24/07 Buriram (Thailand)
- 3** 13-14/08 Kuala Lumpur (Malaysia)
- 4** 24-25/09 Yeongam (South Korea)
- 5** 15-16/10 Penbay (Taiwan)
- 6** 04-05/11 Shanghai (China)

2012

Debut season

2

Car types

Audi R8 LMS, Audi R8 LMS ultra

12

Different race tracks

Between 2012 and 2016

Every champion



2012

Marchy Lee



2013

Adderly Fong





2014 + 2015

Alex Yoong





AUDI RACE EXPERIENCE



License training

- ! Driver training
-  Audi R8 V10 plus Coupé
-  DMSB theory and tests, warm-up, race situations, guided driving
-  Neuburg a. d. Donau, Driving Center Groß Dölln



Experience Audi R8 LMS

- ! Race track experience recommended
-  Audi R8 LMS, Audi R8 V10
-  Guided and free driving
-  Driving Center Groß Dölln



Individual training motorsport

- ! Race track experience useful
-  Audi R8 LMS, Audi R8 V10, Audi TT cup
-  Personal coordination
-  Driving Center Groß Dölln



Experience Audi TT cup

- ! Race track experience recommended
-  Audi R8 V10 plus Coupé, Audi TT cup
-  Guided and free driving
-  Driving Center Groß Dölln



Experience Audi R8 LMS pro

- ! Race track experience
-  Audi R8 LMS, Audi R8 V10
-  Guided and free driving
-  Driving Center Groß Dölln

Audi R8 LMS customer racing

- ! Motorsport license, motorsport experience, track knowledge Nürburgring-Nordschleife
-  Audi R8 LMS
-  Races on the Nürburgring-Nordschleife, e.g. 24h qualification race and 24h Nürburgring
-  Nürburgring

- ! Requirements
-  Training contents

-  Training car
-  Training location

AUDI SPORT RACING ACADEMY

Academy Stages

Stage 1

/ Academy Meetings

Stage 2

/ Academy Meetings

/ Audi Sport TT Cup

Stage 3

/ Academy Meetings

/ GT racing (from 2017)

Candidates for support 2016



*Vivien
Keszthelyi*



*Sheldon
van der Linde*



*Nicklas
Nielsen*



Mentors



*Pierre
Kaffer*



*Rahel
Frey*



*Josef
Haider*



Academy Meetings

Content

- / Nutrition
- / Mental fitness
- / Motorsport technology, Set-up
- / Dealing with sponsors
- / Dealing with the press
- / Public appearance
- / Driver coaching
- / Physical fitness

Objective

To facilitate the move into professional motorsport

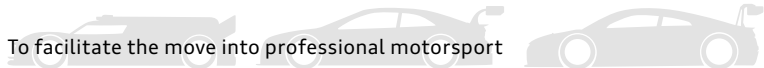

CHAMPIONSHIP TITLES (DRIVERS) IN GT RACING



ADAC GT Masters
Christian Abt (D)

Belgium

Jean-François Hemroulle/Tim Verbergt (B/B)

FIA GT3 (Europe)

Christopher Haase/Christopher Mies (D/D)



Australia
Mark Eddy (AUS)

Blancpain Endurance Series
Greg Franchi (B)

Italy
Marco Bonanomi (I)

Super Taikyu Series
*Tomonobu Fujii/Akihiro Tsuzuki/
Michael Kim (J/J/USA)*

Taça Portugal
César Campaniço/João Figueiredo (P/P)

Spain
César Campaniço/João Figueiredo (P/P)



DMSB-GT-Meisterschaft
Luca Ludwig (D)

Belgium
Greg Franchi/Anthony Kumpen (B/B)

Portugal
César Campaniço/João Figueiredo (P/P)

Spain
César Campaniço/João Figueiredo (P/P)



2012

Blancpain Endurance Series
Christopher Haase/Christopher Mies/
Stéphane Ortelli (D/D/MC)

Portugal

César Campaniço/Carlos Vieira (P/P)

Taça Portugal

César Campaniço/Carlos Vieira (P/P)

Iberian Supercars Trophy

César Campaniço/Carlos Vieira (P/P)

Spain

Mikko Eskelinen (FIN)



2014

ADAC GT Masters

Kelvin van der Linde/René Rast (ZA/D)

Blancpain Endurance Series

Laurens Vanthoor (B)

Blancpain GT Series

Laurens Vanthoor (B)



2013

Belgium

Anthony Kumpen/Bert Longin/
Maarten Makelberge (B/B/B)

FIA GT Series

Stéphane Ortelli/Laurens Vanthoor (MC/B)

GT Sprint International

Thomas Schöffler (D)

Portugal

César Campaniço (P)

Sweden

Jan Brunstedt (S)



2015

Australia

Christopher Mies (D)

Blancpain GT Series

Robin Frijns (NL)

OVERALL VICTORIES IN ENDURANCE RACES



12h Hungary

Thomas Gruber/Philip König/
Walter Lechner/Niki Mayr-Melnhof (A/A/A/A)



12h Bathurst

Christer Jöns/Christopher Mies/
Darryl O'Young (D/D/HK)

24h Nürburgring

Marc Basseng/Christopher Haase/
Frank Stippler/Markus Winkelhock (D/D/D/D)

24h Spa

Andrea Piccini/René Rast/Frank Stippler (I/D/D)

24h Zolder

Marco Bonanomi/Anthony Kumpen
Edward Sandström/Laurens Vanthoor (I/B/S/B)



24h Nürburgring

Christopher Mies/Edward Sandström/
Nico Müller/Laurens Vanthoor (D/S/CH/B)

25h Thunderhill

Guy Cosmo/Tomonabu Fujii/Darren Law/
Johannes van Overbeek (USA/J/USA/USA)

12h Sepang

Stuart Leonard/Stéphane Ortelli/
Laurens Vanthoor (GB/MC/B)



12h Bathurst

Marc Basseng/Christopher Mies/
Darryl O'Young (D/D/HK)

24h Spa

Mattias Ekström/Greg Franchi/
Timo Scheider (S/B/D)

24h Zolder

Enzo Ide/Bert Longin/Xavier Maassen/
François Verbist (B/B/B/B)



24h Nürburgring

Christopher Haase/Christian Mamerow/
René Rast/Markus Winkelhock (D/D/D/D)

24h Spa

René Rast/Laurens Vanthoor/
Markus Winkelhock (D/B/B)



24h Dubai

Alain Ferté/Stuart Leonard/Michael Meadows/
Laurens Vanthoor (F/GB/GB/B)

PARTNERS OF AUDI SPORT CUSTOMER RACING IN GT RACING



akrapovic.com



castrol.com



eibach.de



staeubli.de



mayer-motorsport.com



AUDI SPORT

TT CUP

- 126** Technology
- 130** Basics
- 131** Key personnel
- 132** Drivers
- 136** Circuits
- 138** Statistics
- 139** Partners

TECHNOLOGY AUDI SPORT TT CUP

Development in record time

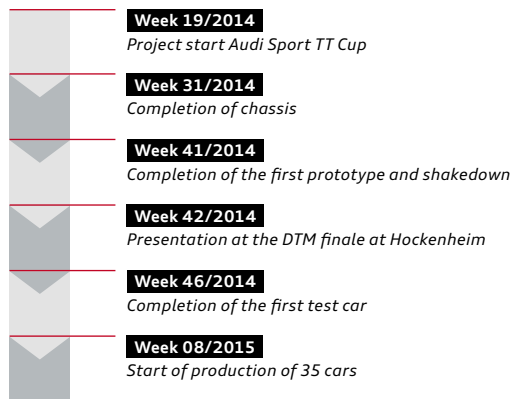

Technology transfer

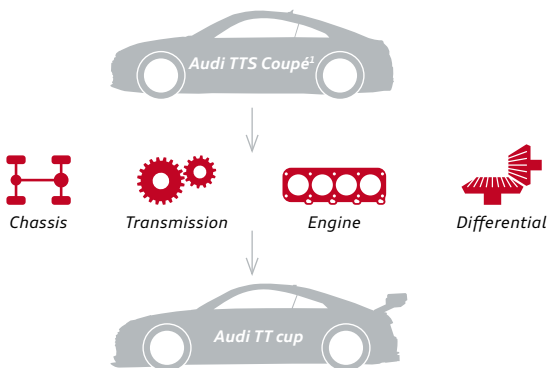

TT CUP

¹ Please refer to the list on page 5 for the consumption and emission values

Push-to-pass – more power at the push of a button

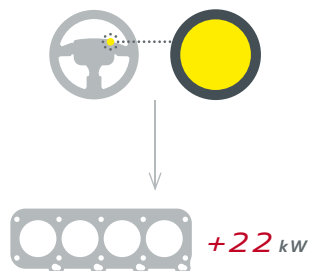

Engine power

By activating the Push-to-pass system the power produced by the Cup car briefly increases from 228 to 250 kW



Push-to-pass procedure

Quantity identical on all circuits, duration and pauses are adapted. Indicated by white LEDs in the rear side window



Push-to-pass in use

Indicated by blue lamps in the windshield

Adjustment options for the driver

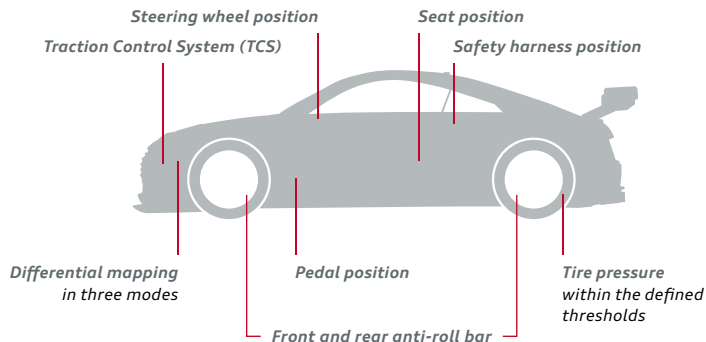

COCKPIT CUP RACE CAR

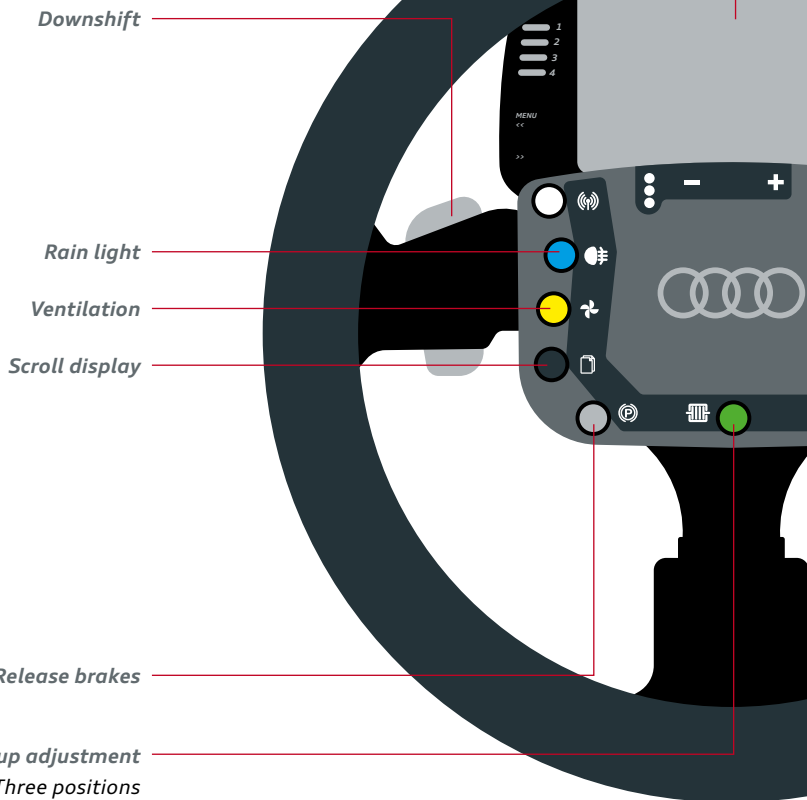

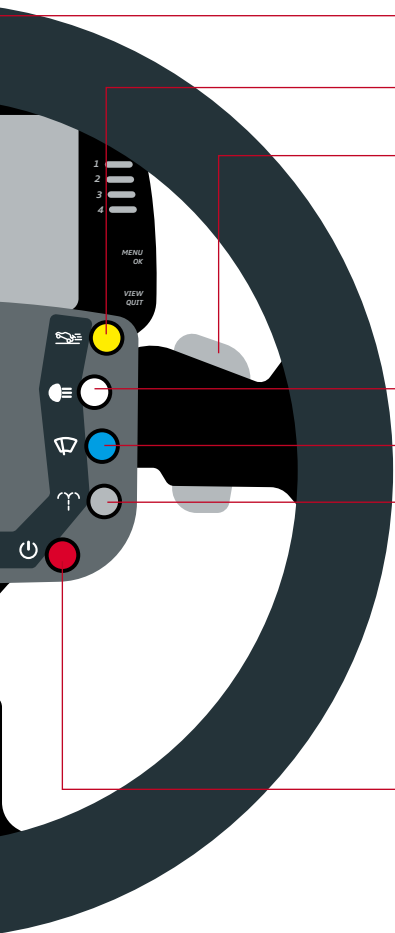

Display

Push-to-pass

Upshift

Main beam

Wiper

Screen wash

Engine start
If car is not moving

Pit speed limit
If car is moving

BASICS AUDI SPORT TT CUP

Race format

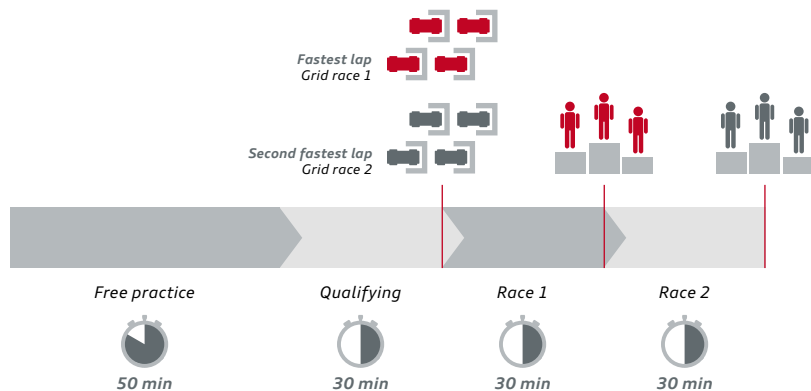

Starters

16 permanent starters (age, sex, nationality)

+ max 8 guest starters
(including VIPs and journalists)

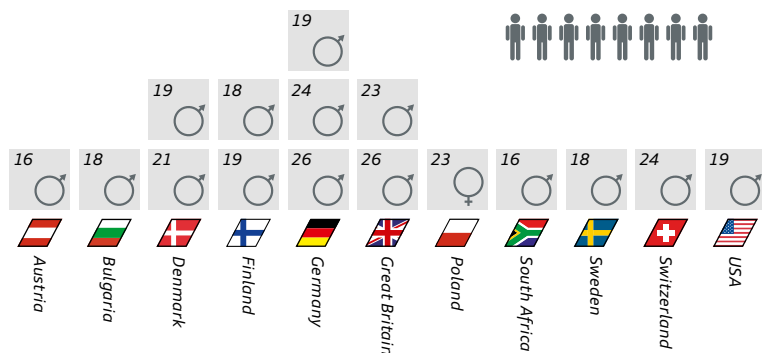

KEY PERSONNEL IN AUDI SPORT TT CUP



Philipp Mondelaers
Project Manager



Detlef Schmidt
Technical Project Manager



Manuel Jahn
Marketing/Partnerships



Christiane Fritz
Marketing/Driver Supervision



Jan-Philipp Heuvel dop
Race Organization



Markus Winkelhock
Coach/Instructor



Marco Werner
Instructor

DRIVERS AUDI SPORT TT CUP

Kevin Strohschänk 



- * May 24, 1989, Kempten (D)
- ▲ Sonthofen (D)
- i Works as car salesman in Audi Zentrum Kempten

 Kevin-Strohschänk-Official-208641085855727

Gosia Rdest 



- * January 14, 1993, Żyrardów (PL)
- ▲ Krakow (PL)
- i Is the only woman after Mikaela Åhlin-Kottulinsky left the series

 Gosia-Rdest-Life-is-a-Race

Joonas Lappalainen 



- * March 01, 1998, Helsinki (FIN)
- ▲ Vantaa (FIN)
- i Prefers to spend his holiday at home in Finland

 joonaslappalainenofficial

Nicklas Nielsen 



- * February 06, 1997, Silkeborg (DK)
- ▲ Hørring (DK)
- i One of the three candidates of the new Audi Sport racing academy

 Nicklas-Nielsen-483503575109941

TT CUP

Pavel Lefterov 🇧🇬



- * November 12, 1997, Varna (BG)
- 📍 Sofia (BG)
- i At a height of 1.90 meters he is unusually tall for a racing driver

bulavtoracing

Christoph Hofbauer 🇩🇪



- * July 15, 1991, Kösching (D)
- 📍 Lippertshofen (D)
- i Started his career only six years ago in karts

christoph.racing

Max Hofer 🇦🇹



- * May 23, 1999, Vienna (A)
- 📍 Perchtoldsdorf (A)
- i Ritual before every race: eyes closed and three deep breaths

maxhofercom

Simon Larsson 🇸🇪



- * May 13, 1997, Lund (S)
- 📍 Bjärred (S)
- i Would buy his own apartment if he won the lottery

SimonLarssonR12

Josh Caygill



- * June 22, 1989, Dewsbury (GB)
- ▲ Huddersfield (GB)
- i Rode motorbikes professionally until the 2013 season

 [joshcaygillracing](#)

Philip Ellis



- * October 09, 1992, Munich (D)
- ▲ Baar (CH)
- i Took a break from motorsport between 2013 and 2015

 [philipellisofficial](#)

Dennis Marschall



- * August 15, 1996, Karlsruhe (D)
- ▲ Eggenstein-Leopoldshafen (D)
- i Title favorite No. 1 on paper. Finished third overall last year

 [Dennis-Marschall-Offizielle-Fanpage](#)

Sheldon van der Linde



- * May 13, 1999, Johannesburg (ZA)
- ▲ Dainfern (ZA)
- i Is the younger brother of Audi GT3 driver Kelvin van der Linde

 [SheldondvLindeFanPage](#)

Emil Lindholm



- * July 19, 1996, Espoo (FIN)
- ▲ Degerby (FIN)
- i Also contests a full season in the sports car series ADAC GT Masters

 [ELindholmRacing](#)

Patrick Egsgaard



- * December 15, 1994, Esbjerg (DK)
- ▲ Esbjerg (DK)
- i Friend of Nicolaj Møller Madsen, the Audi Sport TT Cup 2015 runner up

 [PatrickEgsgaard](#)

Paul Holton



- * October 11, 1996, Tallahassee (USA)
- ▲ Orlando (USA)
- i Flies over the Atlantic for every race weekend

 [pholtonracing](#)

Yves Meyer



- * June 12, 1991, Luzern (CH)
- ▲ Wauwil (CH)
- i Collected motorsport experience in the exotic Time Attack series

 [YMEY-Yves-Meyer-1557958094488668](#)

AUDI SPORT TT CUP CIRCUITS

- / Calendar extended from six to seven events
- / The Netherlands and Hungary: two race weekends abroad
- / For the first time an event during the 24 Hours Nürburgring race week

1 Hockenheim, 07-08/05

4.574 km Track length

1m 48.919s

Lap record qualifying
Joonas Lappalainen, 2015

1m 49.830s

Lap record race
Mikaela Åhlin-Kottulinsky, 2015



2 Nürburgring, 27-28/05

4.638 km Track length

1st Event

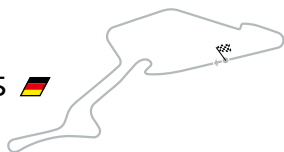

3 Norisring, 25-26/06

2.300 km Track length

58.080s

Lap record qualifying
Shaun Thong, 2015

55.360s

Lap record race
Mikaela Åhlin-Kottulinsky, 2015



TT CUP

4 Zandvoort, 16–17/07 

4.307 km Track length

1st Event

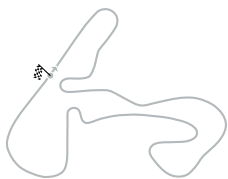

5 Nürburgring, 10–11/09 

3.629 km Track length

1m 35.228s

Lap record qualifying
Emil Lindholm, 2015

1m 35.726s

Lap record race
Jan Kiesel, 2015

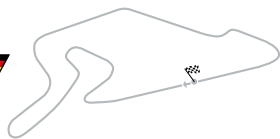

6 Budapest, 24–25/09 

4.381 km Track length

1st Event



7 Hockenheim, 15–16/10 

4.574 km Track length

1m 48.919s

Lap record qualifying
Joonas Lappalainen, 2015

1m 49.830s

Lap record race
Mikaela Åhlin-Kottulinsky, 2015



STATISTICS AUDI SPORT TT CUP¹

Wins



Jan Kisiel



Joonas Lappalainen



*Marc Coleselli, Dennis Marschall,
Nicolaj Møller Madsen,
Shaun Thong, Alexis van de Poele*

Pole positions

3 *Jan Kisiel,
Nicolaj Møller Madsen*

2 *Joonas Lappalainen,
Shaun Thong*

1 *Emil Lindholm,
Alexis van de Poele*

Podiums



Fastest laps



AUDI SPORT TT CUP PARTNERS





CONTACTS

CONTACTS



Jürgen Pippig

Head of Communications Motorsport

Phone +49 841 89-35550

Mobile +49 160 90430634

E-mail juergen.pippig@audi.de



Eva-Maria Becker

Communications LMP

Phone +49 841 89-33922

Mobile +49 173 9393522

E-mail eva-maria.becker@audi.de



Virginia Brusch

*Communications customer racing
and Audi Sport TT Cup*

Phone +49 841 89-41753

Mobile +49 151 52817968

E-mail virginia.brusch@audi.de



Daniel Schuster

Communications DTM

Phone +49 841 89-38009

Mobile +49 151 42134732

E-mail daniel2.schuster@audi.de



Petra Strack

Communications Motorsport

Phone +49 841 89-44784

Mobile +49 172 9101025

E-mail petra.strack@audi.de

***Photos, information and press kits covering every
motorsport program can be found online at
www.audi-mediacycenter.com***

CONTACTS

AUDI AG
Communications Motorsport
D-85045 Ingolstadt

Phone +49 841 8934200
E-mail motorsport-media@audi.de

