

# MediaInfo 2015

## Audi Sport Factbook



 Audi Sport



# Foreword

LMP, DTM, GT racing and the new Audi Sport TT Cup – Audi backs motorsport more consistently than ever before in 2015. The brand's sportiness is accentuated worldwide through the most extensive program in history.

Audi Sport has represented successful motorsport since 1981. Now a brand emerges under which the sporty RS production models and the R8 are also marketed. It's a strong signal that Audi Sport is visible equally on the race tracks as well as on public roads worldwide.

The new Audi Sport Factbook provides a comprehensive summary of this year's Audi Sport program. Facts are quite literally created here – informative and surprising.

Discover 84 subjects on 152 pages, illustrated with 227 graphics, explained by 1,099 figures that should ease your coverage and reporting.



**Jürgen Pippig**

AUDI AG

Head of Communications Motorsport

# Contents

## **Audi in motorsport 2015** **6**

Audi's motorsport program 2015 ...	8
Event calendar .....	10
Our race cars 2015 .....	12

## **WEC** **28**

Audi's innovations at Le Mans .....	32
Audi R18 e-tron quattro: engine ...	33
Audi R18 e-tron quattro: hybrid system .....	34
Principle of recuperation .....	36
Recuperated hybrid energy .....	37
A glance in the R18 cockpit .....	38
FIA World Endurance Championship (WEC) .....	40
Key personnel in the LMP program .....	42

## **DTM** **72**

Audi RS 5 DTM: safety elements ...	76
Drag Reduction System (DRS) .....	78
A glance in the RS 5 DTM cockpit...	80
DTM race weekend format .....	82
Every DTM year .....	84
The average DTM Champion .....	85

## **Audi Sport** **14**

The brand Audi Sport .....	16
Key personnel in Audi's motorsport program .....	18
Audi Neuburg .....	20
Audi Sport – a success story .....	22

Drivers and engineers .....	43
Audi Sport Team Joest .....	44
The nine drivers – a quick profile ...	45
The eight tracks – a summary .....	54
Every winner of the 24h Le Mans ...	63
All 14 circuit versions ever used for the 24h Le Mans .....	67
Audi's LMP titles and great endurance race victories .....	68
Every victory for Audi's LMP race cars 1999–2014 .....	69
Partners of Audi Sport in the WEC ...	70

Key personnel in the DTM program .....	86
Teams and drivers .....	88
Audi Sport Team Abt Sportsline ....	89
Audi Sport Team Phoenix .....	90
Audi Sport Team Rosberg .....	91



The eight drivers – a quick profile.....	92	Best Audi drivers each season .....	110
The tracks – a summary .....	100	Winning ratio by car .....	111
Titles and victories in the DTM ....	109	Partners of Audi Sport in the DTM .	112

## **GT racing** **114**

Audi R8 LMS – 2016 model.....	118	Audi R8 LMS Cup .....	126
A glance in the R8 LMS cockpit....	120	Audi race experience.....	127
The Audi R8 LMS in action worldwide.....	122	Championship titles (drivers) in GT racing .....	128
Key personnel in the GT racing program .....	124	Overall victories in endurance races.....	130
Endurance test for the new R8 LMS.....	125	Partners of Audi Sport customer racing in GT racing.....	131

## **Audi Sport TT Cup** **132**

Audi Sport TT Cup – development in record time.....	136	Centralized preparation of Cup race cars.....	143
Endurance testing at Motorland Aragón .....	137	The Audi Sport TT Cup .....	144
Push-to-pass – more power at the push of a button.....	138	Audi Sport TT Cup drivers .....	146
Overtaking with Push-to-pass .....	139	Partners in the Audi Sport TT Cup ..	150
A glance in the Cup race car cockpit.....	140	Consumption values .....	151
Key personnel in the Audi Sport TT Cup .....	142		

## **Contacts** **152**



# Audi in Motorsport 2015



# Audi's motorsport program 2015

## WEC

Audi R18 e-tron quattro



## DTM

Audi RS 5 DTM



## GT racing

Audi R8 LMS



## Audi Sport TT Cup

Audi TT cup



## Event calendar

### WEC

<b>1</b>	12/04	6h Silverstone (GB)
<b>2</b>	02/05	6h Spa-Francorchamps (B)
<b>3</b>	13-14/06	24h Le Mans (F)
<b>4</b>	30/08	6h Nürburgring (D)
<b>5</b>	19/09	6h Austin (USA)
<b>6</b>	11/10	6h Fuji (J)
<b>7</b>	01/11	6h Shanghai (CN)
<b>8</b>	21/11	6h Bahrain (BRN)

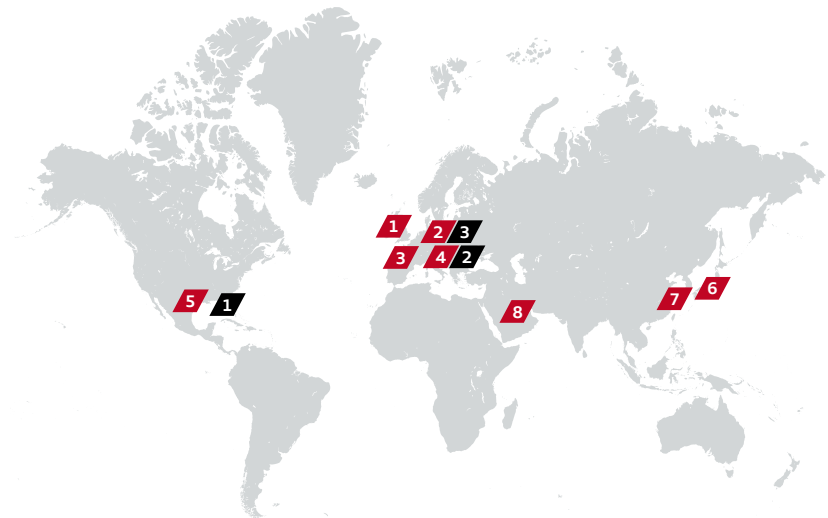

### Important 24-hour races

<b>1</b>	24-25/01	24h Daytona (USA)
<b>2</b>	16-17/05	24h Nürburgring (D)
<b>3</b>	25-26/07	24h Spa-Francorchamps (B)

### DTM / Audi Sport TT Cup

<b>1</b>	02-03/05	Hockenheim (D)	<b>6</b>	29-30/08	Moscow (RUS)
<b>2</b>	30-31/05	Lausitzring (D)	<b>7</b>	12-13/09	Oschersleben (D)
<b>3</b>	27-28/06	Norisring (D)	<b>8</b>	26-27/09	Nürburgring (D)
<b>4</b>	11-12/07	Zandvoort (NL)	<b>9</b>	17-18/10	Hockenheim (D)
<b>5</b>	01-02/08	Spielberg (A)			

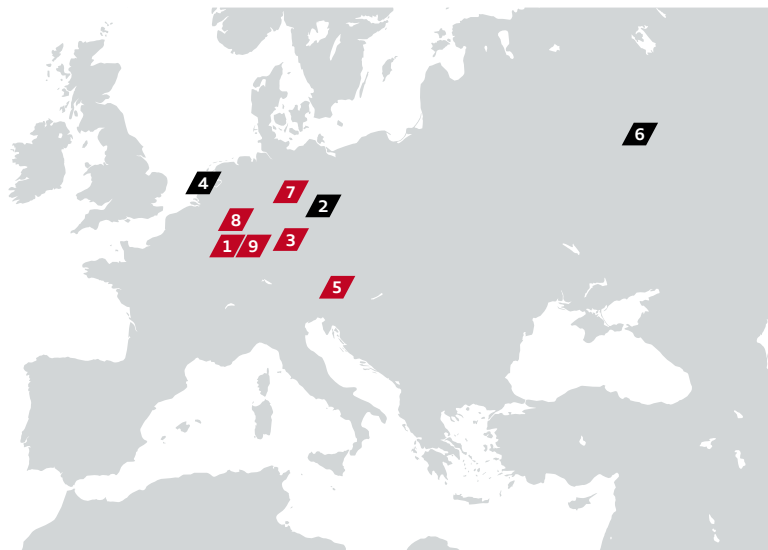

**1** DTM and Audi Sport TT Cup race at same event

**2** DTM only event

## Our race cars 2015



### Audi R18 e-tron quattro

Car type	LMP1 sports car	Cylinders	V6
Weight	870 kg	Power	610 kW (with Hybrid)
Length	4,650 mm	Power/weight ratio	1.4 kg/kW (with Hybrid)
Engine type	TDI	0-100 km/h	2.6s
Displacement	4,000 cc	Top speed	324 km/h



### Audi RS 5 DTM

Car type	DTM touring car	Cylinders	V8
Weight	1,120 kg (incl. driver)	Power	340 kW
Length	5,010 mm	Power/weight ratio	3.4 kg/kW
Engine type	Normally aspirated	0-100 km/h	2.9s
Displacement	4,000 cc	Top speed	280 km/h





## Audi R8 LMS

<i>Car type</i>	<i>GT3 sports car</i>	<i>Cylinders</i>	<i>V10</i>
<i>Weight</i>	<i>1,225 kg</i>	<i>Power</i>	<i>430 kW</i>
<i>Length</i>	<i>4,583 mm</i>	<i>Power/weight ratio</i>	<i>2.8 kg/kW</i>
<i>Engine type</i>	<i>Normally aspirated</i>	<i>0-100 km/h</i>	<i>2.75s</i>
<i>Displacement</i>	<i>5,200 cc</i>	<i>Top speed</i>	<i>295 km/h</i>



## Audi TT cup

<i>Car type</i>	<i>Cup touring car</i>	<i>Cylinders</i>	<i>4 (inline)</i>
<i>Weight</i>	<i>1,125 kg</i>	<i>Power</i>	<i>228 kW/250 kW (with Push-to-pass)</i>
<i>Length</i>	<i>4,260 mm</i>	<i>Power/weight ratio</i>	<i>4.9 kg/kW</i>
<i>Engine type</i>	<i>TFSI</i>	<i>0-100 km/h</i>	<i>4.5s</i>
<i>Displacement</i>	<i>1,984 cc</i>	<i>Top speed</i>	<i>239 km/h</i>



**Audi Sport**



# The brand Audi Sport

- / Audi Sport has represented successful motorsport since 1981
- / Audi Sport has evolved into a unique brand, to which Audi's most sporty production models now belong as well
- / The majority of the activities are pooled in the new Competence Center Motorsport in Neuburg

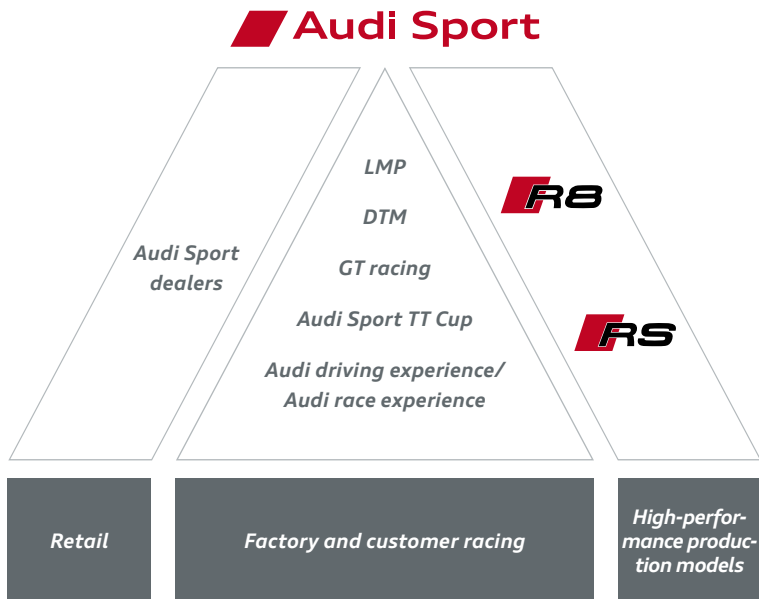

## Current high-performance model range



*Audi RS 3 Sportback*



*Audi RS 4 Avant*



*Audi RS 5 Cabriolet*



*Audi RS 5 Coupé*



*Audi RS 6 Avant*



*Audi RS 7 Sportback*



*Audi RS Q3*



*Audi R8 Coupé*

# Management functions in Audi's motorsport program

## Audi Sport



**Chris Reinke**  
Head of LMP

Continues  
on page 42



**Dr. Wolfgang Ullrich**  
Head of Audi Sport



**Dieter Gass**  
Head of DTM

Continues  
on page 86



**Jörg Zander**  
Head of Engineering



**Klaus Dieter Krieger**  
Head of Finance  
and Organization

## Technology



**Wolfgang-Dieter Appel**  
Head of  
Vehicle Development



**Ulrich Baretzky**  
Head of Engine  
Development



**Joachim Hausner**  
Head of  
Complete Vehicle



**Norbert Medele**  
Head of  
Workshop



**Thomas Laudenschlager**  
Head of Electronics,  
Electronics,  
Hybrid

## Finance and Organization



**Siegfried Krause**  
Head of Procurement  
and Partnerships



**Rainer Kammergruber**  
Head of Audi Sport  
Race Organization

## Customer racing

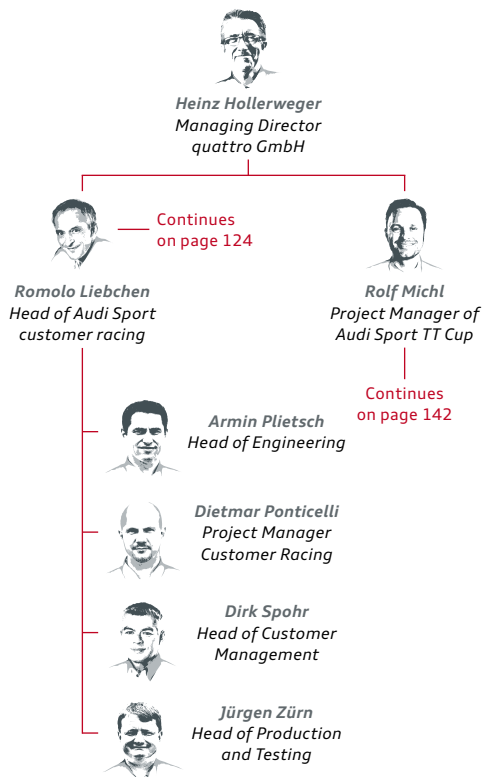

# Audi Neuburg

- / Audi driving experience center
- / Competence Center Motorsport/Audi Sport
- / Audi Sport customer racing
- / Development functions of Technical Development

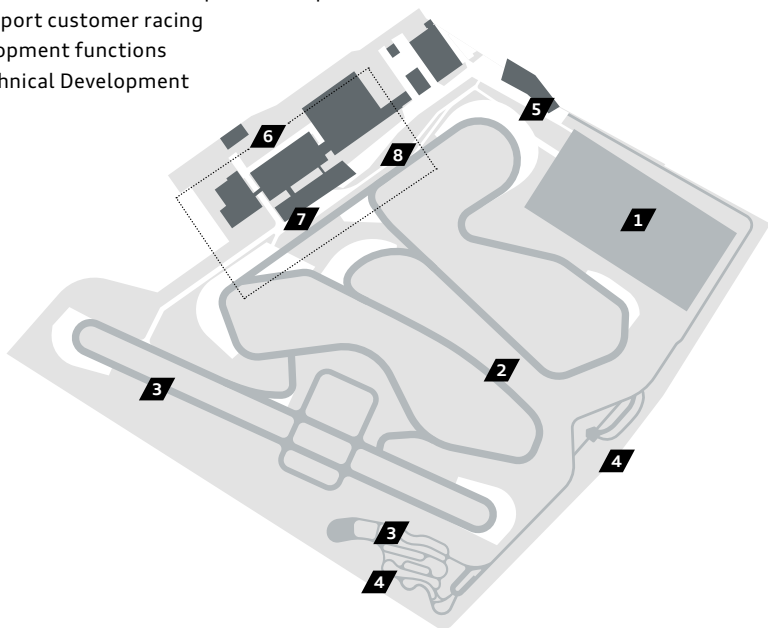

**2010-2011**

*Land purchase and drafting of development plan*

**August 2012**

*Ground-breaking ceremony*

**2011-2012**

*Planning stage*



**1** 30,000 m<sup>2</sup>  
Vehicle dynamics test area

**2** 2.2 km  
Handling circuit

**3** 1.2 km  
Straight

**4** 10  
Off-road module

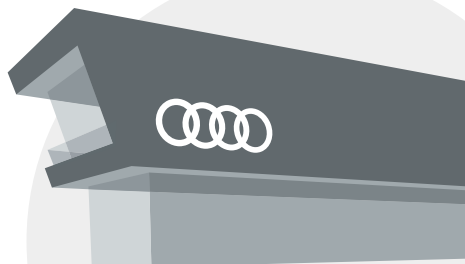

**5** Audi driving experience center

**6** Competence Center Motorsport

**7** Audi Sport

**8** Audi Sport customer racing

**460** Employees Competence Center Motorsport  
(350 Audi employees, 110 employees from partner companies)



**May 2014**

Commissioning  
Audi driving experience center

**Spring 2015**

Commissioning  
Audi Sport customer racing

**November 2013**

Topping-out ceremony  
Motorsport building

**August 2014**

Opening Audi Neuburg / Commissioning  
Competence Center Motorsport / Audi Sport

# Audi Sport – a success story

## Head of Audi Sport

Jürgen Stockmar (D), Walter Treser (D) Reinhard Rode (D)

Roland Gumpert (D)

1980

1981

1982

Testing



*Audi quattro*

Rallying



*Audi quattro*



*Audi quattro<sup>1</sup>*

<sup>1</sup> Rally World Champion  
Manufacturer

## Herwart Kreiner (A)

1986

1987

1988

Rallying



*Audi Sport quattro S1*



*Audi 200 quattro*

Trans Am



*Audi 200 quattro<sup>4</sup>*



*Audi Gruppe S<sup>2</sup>*



*Audi Coupé quattro*

Pikes Peak



*Audi Sport quattro S1<sup>2</sup>*



*Audi Sport quattro S1<sup>3</sup>*

<sup>1</sup> No races

<sup>2</sup> Winner Pikes Peak

<sup>3</sup> Winner Pikes Peak

<sup>4</sup> Winner Trans Am

1983 1984 1985

Rallying



*Audi quattro A1 and A2<sup>1</sup>*



*Audi quattro A2<sup>2</sup>*



*Audi Sport quattro*



*Audi 80 quattro*



*Audi Sport quattro<sup>2</sup>*



*Audi Sport quattro S1*

Pikes Peak



*Audi Sport quattro*



*Audi Sport quattro<sup>3</sup>*

<sup>1</sup>Rally World Champion

<sup>2</sup>Rally World Champion  
Driver & Manufacturer

<sup>3</sup>Winner Pikes Peak

Dieter Basche (D)

1989 1990 1991

IMSA GTO



*Audi 90 quattro*

DTM



*Audi V8 quattro<sup>1</sup>*



*Audi V8 quattro<sup>2</sup>*

<sup>1</sup>Winner DTM

<sup>2</sup>Winner DTM

Dr. Wolfgang Ullrich (A)

1992

1993

1994

DTM



*Audi V8 quattro*



*Audi 80 DTM Class 1<sup>1</sup>*

Super Touring Cars



*Audi 80 quattro<sup>2</sup>*



*Audi 80 competition<sup>3</sup>*

<sup>1</sup> No races

<sup>2</sup> French Touring Cars Champion

<sup>3</sup> Italian Touring Car Champion

1998

1999

2000

Super Touring Cars



*Audi A4*

Sports car LMP



*Audi R8R*



*Audi R8<sup>1</sup>*



*Audi R8R*

Sports car LMGT-P



*Audi R8C*

<sup>1</sup> Winner 24h Le Mans,  
Winner ALMS  
Driver & Manufacturer

1995

1996

1997

Super Touring Cars



*Audi A4 quattro<sup>1</sup>*



*Audi A4 quattro<sup>2</sup>*



*Audi A4 quattro<sup>3</sup>*



*Audi A4*

<sup>1</sup> Italian Touring Car Champion,  
Winner Touring Car World Cup

<sup>2</sup> Super Touring Car Champion in  
Australia, Belgium, Germany,  
Great Britain, Italy, South  
Africa & Spain

<sup>3</sup> Central European Touring  
Car Champion

2001

2002

2003

Sports car LMP



*Audi R8<sup>1</sup>*



*Audi R8<sup>2</sup>*



*Audi R8<sup>3</sup>*

<sup>1</sup> Winner 24h Le Mans,  
Winner ALMS  
Driver & Manufacturer,  
Winner European Le Mans Series

<sup>2</sup> Winner 24h Le Mans,  
Winner ALMS  
Driver & Manufacturer

<sup>3</sup> Winner ALMS  
Driver & Manufacturer

2004

2005

2006

Sports car LMP



Audi R8<sup>1</sup>



Audi R8<sup>3</sup>



Audi R8<sup>4</sup>

Sports car LMP1



Audi R10 TDI<sup>5</sup>

DTM



Audi A4 DTM<sup>2</sup>



Audi A4 DTM



Audi A4 DTM

<sup>1</sup> Winner 24h Le Mans, Winner ALMS Driver & Manufacturer, Winner Le Mans Endurance Series

<sup>2</sup> Winner DTM Driver & Manufacturer

<sup>3</sup> Winner 24h Le Mans, Winner ALMS Driver & Manufacturer

<sup>4,5</sup> Winner ALMS Driver & Manufacturer

<sup>5</sup> Winner 24h Le Mans

2010

2011

2012

Sports car LMP1



Audi R15 TDI<sup>1</sup>



Audi R18 TDI<sup>2</sup>



Audi R18 e-tron quattro<sup>4</sup>/ultra

DTM



Audi A4 DTM



Audi A4 DTM<sup>3</sup>



Audi A5 DTM

Customer racing



Audi R8 LMS



Audi R8 LMS



Audi R8 LMS/ultra/GRAND-AM



Audi TT RS

<sup>1</sup> Winner 24h Le Mans

<sup>2</sup> Winner 24h Le Mans

<sup>3</sup> Winner DTM

<sup>4</sup> Winner 24h Le Mans, Winner FIA WEC Driver & Manufacturer

2007

2008

2009

Sports car LMP1

*Audi R10 TDI<sup>1</sup>**Audi R10 TDI<sup>3</sup>**Audi R15 TDI*

DTM

*Audi A4 DTM<sup>2</sup>**Audi A4 DTM<sup>4</sup>**Audi A4 DTM<sup>5</sup>*

Customer racing

*Audi R8 LMS*

<sup>1</sup> Winner 24h Le Mans,  
Winner ALMS  
Driver & Manufacturer

<sup>2</sup> Winner DTM

<sup>3</sup> Winner 24h Le Mans, Winner  
ALMS Driver & Manufacturer,  
Winner Le Mans Series

<sup>4</sup> Winner DTM

<sup>5</sup> Winner DTM

2013

2014

2015

Sports car LMP1

*Audi R18 e-tron quattro<sup>1</sup>**Audi R18 e-tron quattro<sup>3</sup>**Audi R18 e-tron quattro*

DTM

*Audi RS 5 DTM<sup>2</sup>**Audi RS 5 DTM<sup>4</sup>**Audi RS 5 DTM*

Customer racing

*Audi R8 LMS/ultra/GRAND-AM**Audi R8 LMS/ultra**Audi R8 LMS/ultra**Audi TT cup*

<sup>1</sup> Winner 24h Le Mans,  
Winner FIA WEC  
Driver & Manufacturer

<sup>2</sup> Winner DTM

<sup>3</sup> Winner 24h Le Mans  
<sup>4</sup> Winner DTM Manufacturer





WEC

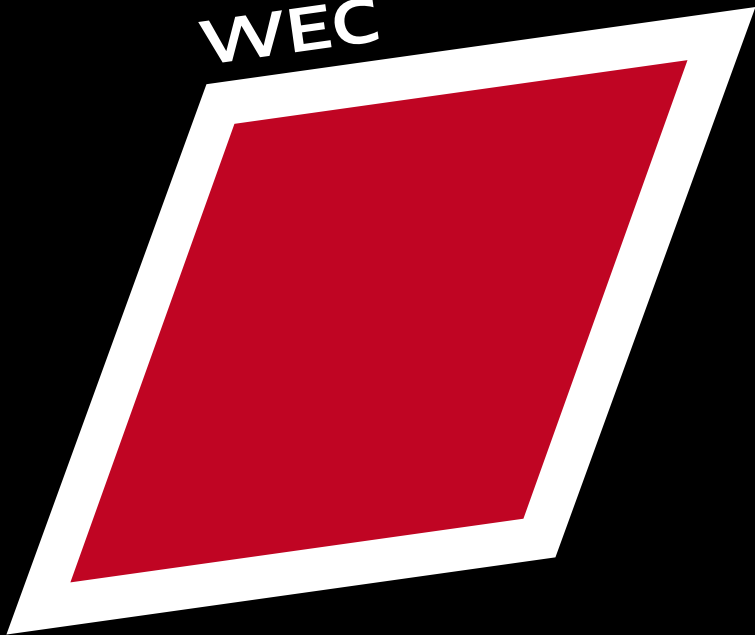

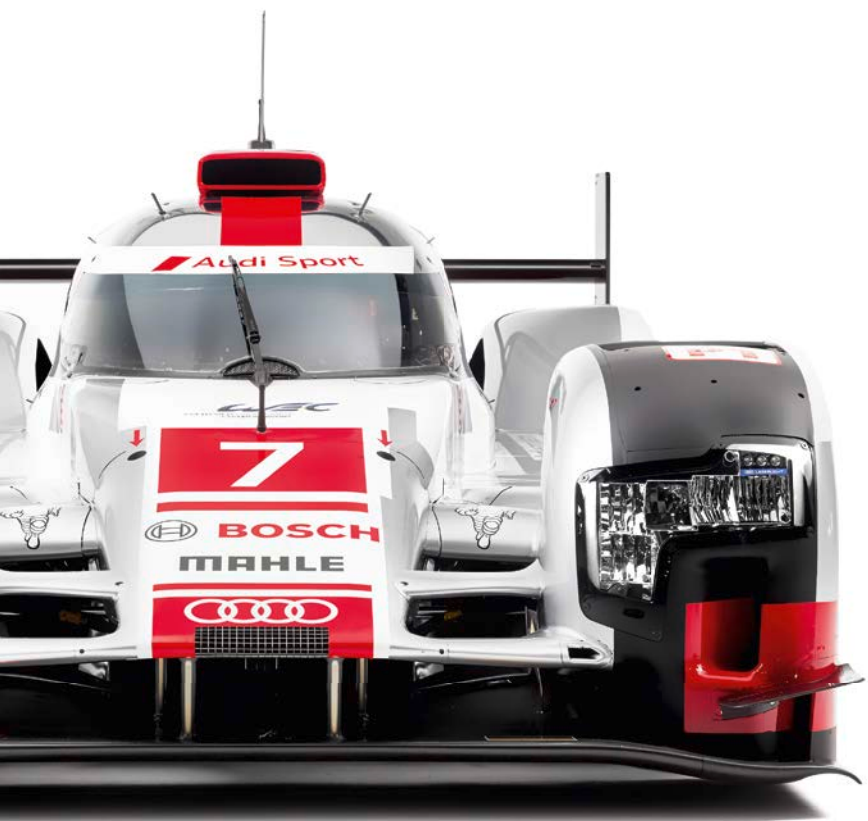

# Contents

---

Audi's innovations at Le Mans .....	32
Audi R18 e-tron quattro: engine .....	33
Audi R18 e-tron quattro: hybrid system .....	34
Principle of recuperation .....	36
Recuperated hybrid energy .....	37
A glance in the R18 cockpit .....	38
FIA World Endurance Championship (WEC) .....	40
Key personnel in the LMP program .....	42
Drivers and engineers .....	43
Audi Sport Team Joest .....	44
The nine drivers – a quick profile .....	45
The eight tracks – a summary .....	54
Every winner of the 24h Le Mans .....	63
All 14 circuit versions ever used for the 24h Le Mans ..	67
Audi's LMP titles and great endurance race victories ...	68
Every victory for Audi's LMP race cars 1999–2014 .....	69
Partners of Audi Sport in the WEC .....	70

# Audi's innovations at Le Mans

**2001**

*TFSI technology*

**2006**

*TDI technology / LED daytime driving lights*

**2009**

*Lithium ion battery / V10 TDI replaces V12 TDI / Turbocharger with VTG control*

**2010**

*LED light technology*

**2011**

*Downsizing from V10 TDI (5.5 Liter) to V6 TDI (3.7 Liter) / Dual-flow pressurized mono turbocharger / Full LED headlights / Intensification of ultra lightweight design*

**2012**

*Hybrid drive e-tron quattro with hybrid powertrain 150 kW / Matrix LED headlights*

**2013**

*Power increase of hybrid system to more than 160 kW*

**2014**

*Efficiency regulations (consumption reduction compared to 2006: minus 38 per cent) / V6 TDI (4 liter) / Audi Laserlight / Optimization lightweight design: first Audi LMP race car, which is lighter than 900 kg (870 kg) / Power increase of hybrid system to more than 170 kW / Accumulator capacity 600 kJ / Reduction of car and tire width / Significant aerodynamic optimization*

**2015**

*Redesign of V6 TDI to further reduce consumption / Power increase of hybrid system to more than 200 kW, Accumulator capacity 700 kJ / Further optimization of lightweight design / Significant aerodynamic optimization*

# Audi R18 e-tron quattro: engine

## VTG turbocharger

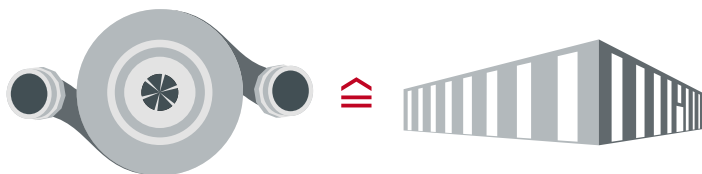

- / Supplies 2,000 kg air per hour at full load (4 bar)
- / At an air density of  $1.3 \text{ kg/m}^3$  the resulting volume is  $1,538.46 \text{ m}^3$

- / This equates to the volume of an empty factory with internal dimensions of 10 meters long, 10 meters wide and 15.38 meters high

## V6 TDI injection pressure

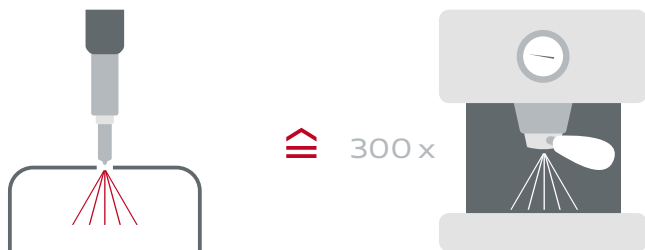

- / The diesel fuel is injected at a pressure of 3,000 bar into the combustion chamber of the V6 TDI powering the R18 e-tron quattro

- / To compare: the pressure is 300 times greater than the brewing pressure used by an Espresso machine

## Audi R18 e-tron quattro: hybrid system

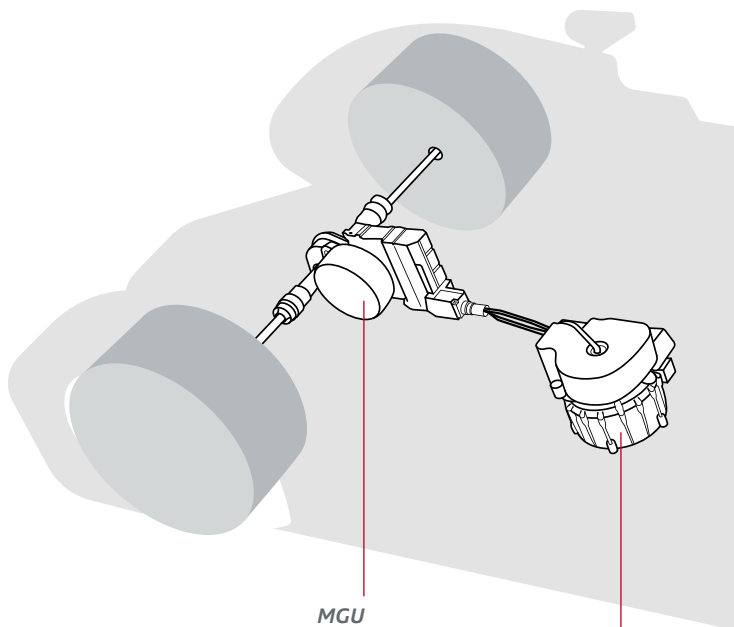

### **MGU**

*The Motor Generator Unit (MGU) converts the kinetic energy recovered during braking into electricity. And vice versa, the MGU can drive the front axle with the energy recovered.*

### **Flywheel accumulator**

*The flywheel accumulator in the cockpit is charged by the MGU. It runs at more than 45,000 rpm and has a useable reserve of 700 Kilojoule.*

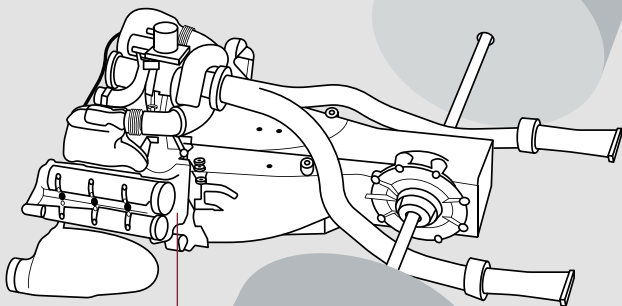

**V6 TDI engine**

*The powerful and efficient V6 TDI with 558 hp drives the rear axle. It consumes 40 per cent less energy than Audi's first V12 TDI used at Le Mans in 2006.*

## Principle of recuperation

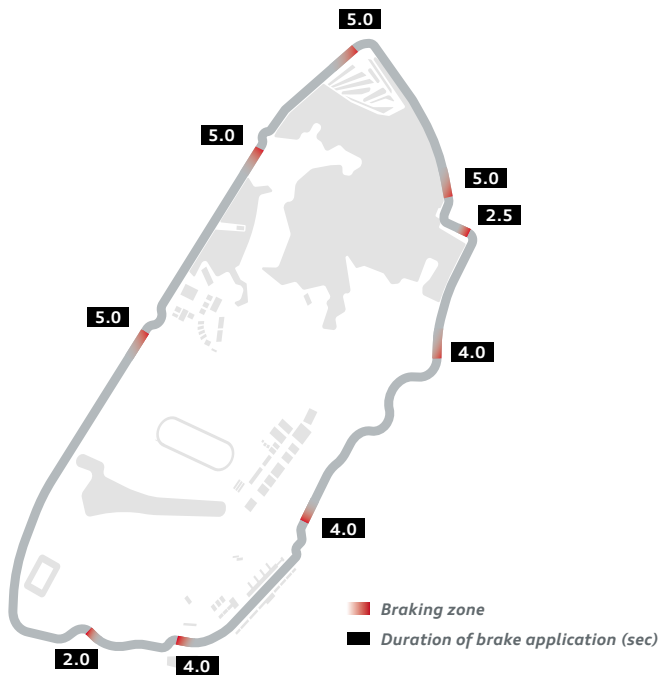

- / Using the circuit map of Le Mans, it can be seen at which points the Audi R18 e-tron quattro recovers energy with its hybrid system
- / There are nine braking zones for recuperation
- / Every brake application lasts between two and five seconds
- / The energy is used to accelerate on the corner exit
- / The Audi R18 e-tron quattro can use a maximum of four Megajoules of hybrid energy per lap at Le Mans



## Recuperated hybrid energy

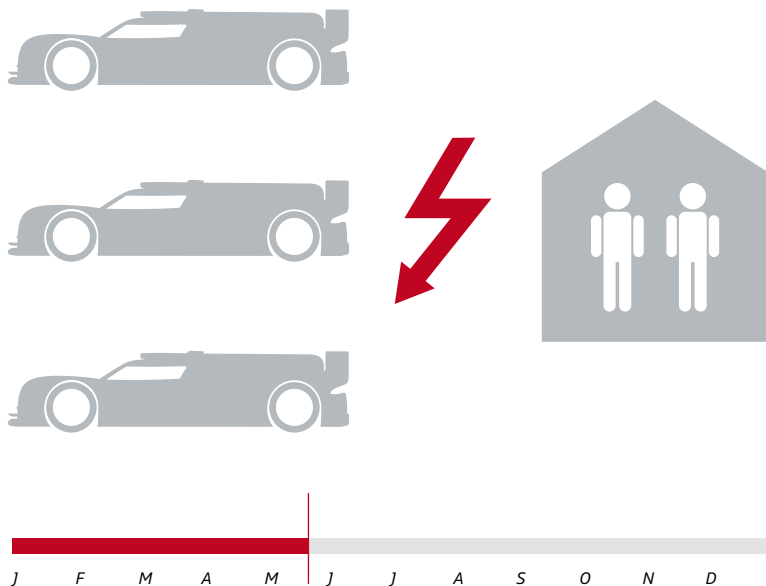

- / Three Audi R18 e-tron quattro recuperate a total of 4,548 Megajoules over the distance of a complete 24-hour race at Le Mans<sup>1</sup>
- / 4,548 Megajoules equal 1,263 kWh
- / A German two person household uses 3,248 kWh per annum<sup>2</sup>
- / With the energy recuperated, you could supply this household for 141.9 days assuming constant consumption – from January 1 to May 21

<sup>1</sup> Measured over 379 race laps (like when Audi won Le Mans in 2014)

<sup>2</sup> Source: Energy Agency NRW

# A glance in the R18 cockpit

AMOLED display for  
digital rearview mirror

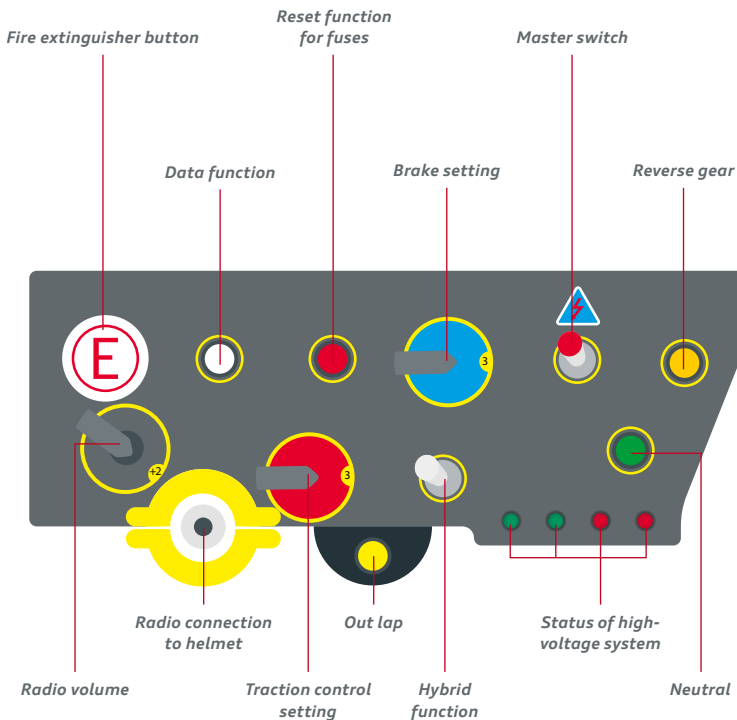
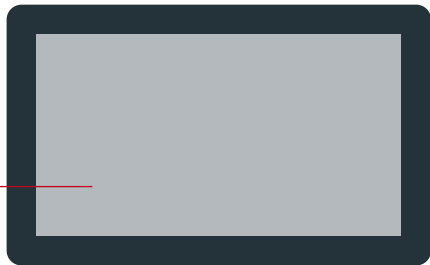

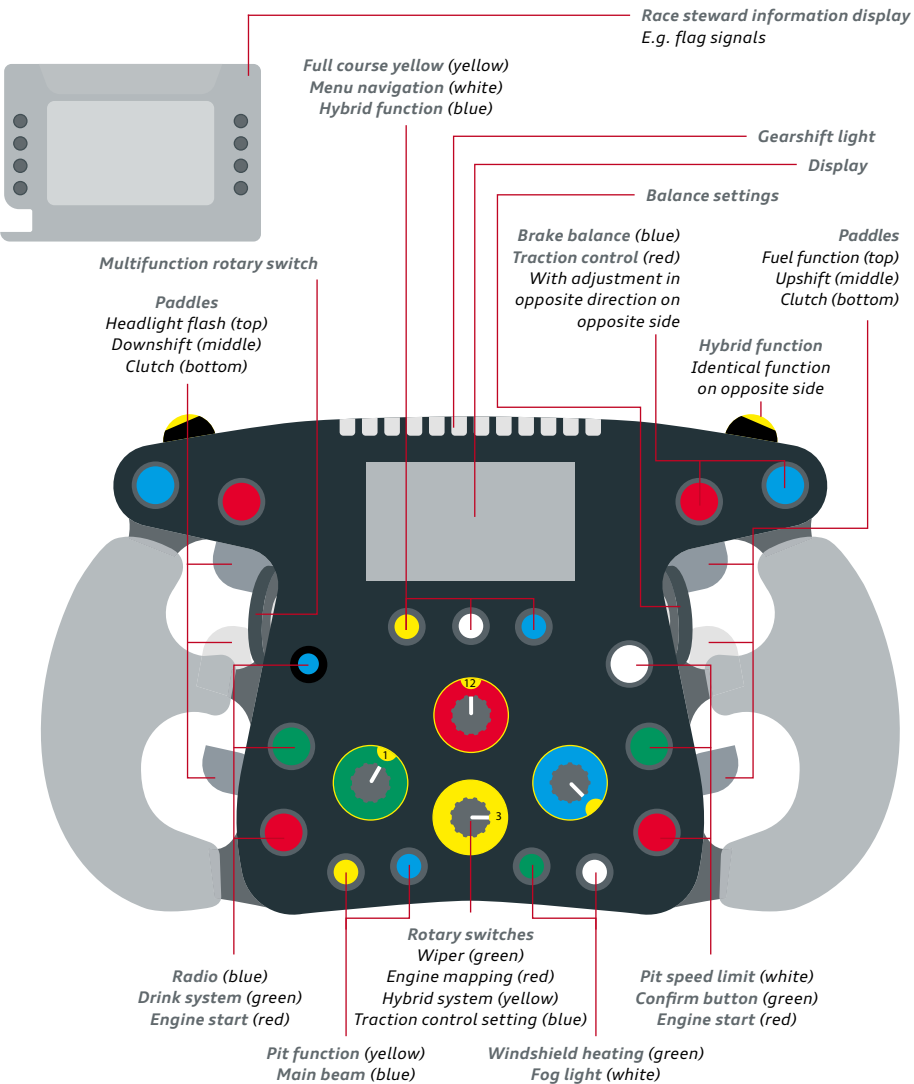

# FIA World Endurance Championship (WEC)

## Manufacturers in the LMP1 category

2012



Audi

TOYOTA HYBRID

Toyota

2013



Audi

TOYOTA HYBRID

Toyota

2014



Audi



Porsche

TOYOTA HYBRID

Toyota

2015



Audi

NISSAN  
nismo

Nissan



Porsche

TOYOTA HYBRID

Toyota

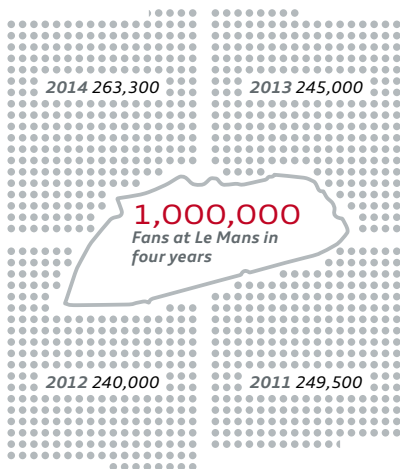

## Classes

	LMP1	LMP2
<b>Race car</b>	Closed prototype	Open or closed prototype
<b>Categories</b>	With energy recuperation (hybrid) for manufacturers and without hybrid for private teams	-
<b>Price</b>	-	Max 370,000 € Max 450,000 € (closed car)
<b>Displacement</b>	Free (hybrid) Max 5,500 cm <sup>3</sup> (without hybrid)	Max 5,000 cm <sup>3</sup> (normally aspirated) Max 3,200cm <sup>3</sup> (turbo)
<b>Cylinders</b>	Free	Max 8 (normally aspirated) Max 6 (turbo)
<b>Weight</b>	Min 870 kg (hybrid) Min 850 kg (without hybrid)	Min 900 kg
<b>Length</b>	Max 4,650 mm	Max 4,650 mm
<b>Width</b>	1,800-1,900 mm	Max 2,000 mm
<b>Driver</b>	Bronze drivers not permitted	Minimum 1 bronze or silver driver per car

## Fan profile WEC 2014



**22%**   **78%**

*Average age*  
36   38

*Social class*  
Middle class   Upper and middle class

*General interests*  
Family, racing drivers   Technology, racing drivers

## Important links

**FIA** #FIA

 [fia.com](http://fia.com)

 [fia](#)

 [@fia](#)

**WEC** #WEC

 [fiawec.com](http://fiawec.com)

 [fiawec](#)

 [@fiawec](#)

**ACO**

 [lemans.org](http://lemans.org)

**Audi Sport**

#AudiSport #WEC #welcomechallenges

 [audi-motorsport.com](http://audi-motorsport.com)

 [AudiSport](#)

 [@Audi\\_Sport](#)

### **GTE-PRO**

GT sports car with 2 doors

-

-

Max 5,500 cm<sup>3</sup> (normally aspirated)

Max 4,000 cm<sup>3</sup> (turbo)

Free

Min 1,245 kg

Max 4,800 mm

Max 2,050 mm

Free

### **GTE-AM**

GT sports car with 2 doors

Cars must be at least 1 year old

-

Max 5,500 cm<sup>3</sup> (normally aspirated)

Max 4,000 cm<sup>3</sup> (turbo)

Free

Min 1,245 kg

Max 4,800 mm

Max 2,050 mm

Minimum 1 bronze or silver driver per car

## Key personnel in the LMP program



**Chris Reinke**  
Head of LMP



**Tristan Summerscale**  
Project Manager  
Vehicle Development



**Hartmut Diel**  
Project Manager  
Engine Development



**Andreas Roos**  
Project Manager  
Racing



**Dominic Zeidler**  
Project Manager  
Testing



**Dieter Meissler**  
Project Manager  
Vehicle Build-up



**Holger Turczynski**  
Project Manager Electrics,  
Electronics, Hybrid



**Elmar Adler**  
Partnerships

## Audi Sport Team Joest



**Reinhold Joest**  
Team Owner



**Ralf Jüttner**  
Team Director

# Drivers and engineers

7

*Marcel Fässler (CH)*

*André Lotterer (D)*

*Benoît Tréluyer (F)*



*Leena Gade*  
Vehicle engineer  
R18 #7

8

*Lucas di Grassi (BR)*

*Loïc Duval (F)*

*Oliver Jarvis (GB)*



*Justin Taylor*  
Vehicle engineer  
R18 #8

9

*Filipe Albuquerque (P)*

*Marco Bonanomi (I)*

*René Rast (D)*



*Matthias Huber*  
Vehicle engineer  
R18 #9

# Audi Sport Team Joest

1978

Founded

Since 1999

Partner of Audi

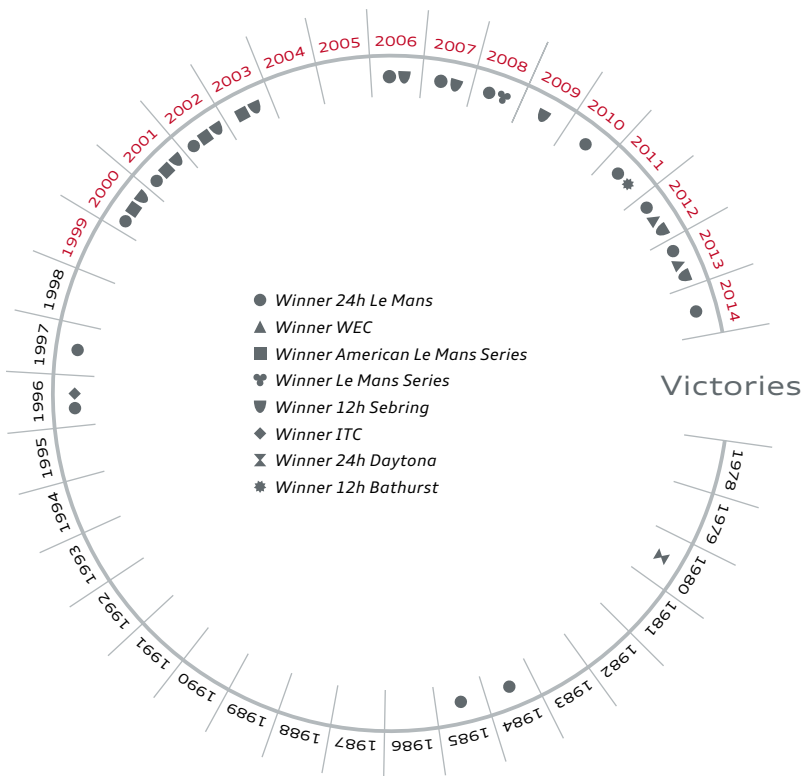





# Filipe Albuquerque



\* June 13, 1985, Coimbra (P)  
▲ Coimbra (P)

## Hobbies



Soccer



Jogging

## Marital status



Single

## Statistics

### WEC | Le Mans

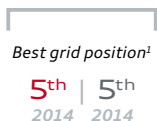
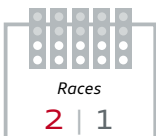

## Career highlights

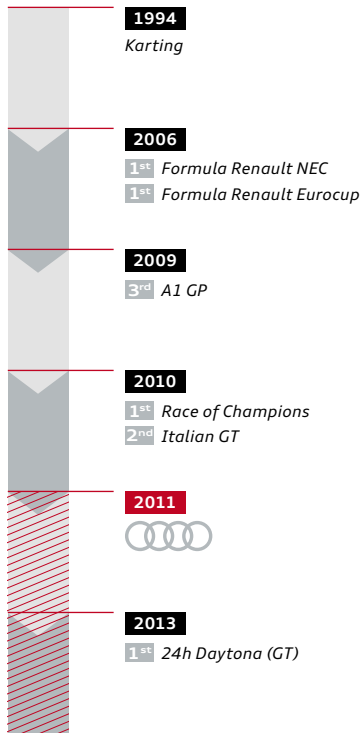

 [filipealbuquerque.com](http://filipealbuquerque.com)

 [filipe.albuquerque1](https://www.facebook.com/filipe.albuquerque1)

 @AlbuquerqueFil

<sup>1</sup> Car grid position

WEC



# Marco Bonanomi



1.76 m

\* March 12, 1985, Lecco (I)

▲ Colle Brianza (I)

## Hobby



Triathlon

## Marital status



Single

## Statistics

### WEC | Le Mans

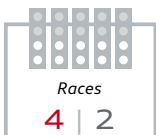

Best grid position<sup>1</sup>  
**2<sup>nd</sup>** | **5<sup>th</sup>**  
2012 | 2014

Best result  
**3<sup>rd</sup>** | **3<sup>rd</sup>**  
2x | 2012

## Career highlights

**1998**

Karting

**2006**2<sup>nd</sup> Formula 3000 Euroseries**2009**2<sup>nd</sup> Formula 3000 Euroseries**2010**2<sup>nd</sup> Italian GT3**2011**1<sup>st</sup> Italian GT3**2012**1<sup>st</sup> 24h Zolder3<sup>rd</sup> 24h Le Mans

 [marcobonanomi.com](http://marcobonanomi.com)

 [marcobonanomi.racing](https://www.facebook.com/marcobonanomi.racing)

 @MarcoBonanomi



# Lucas di Grassi



1.79 m

\* August 11, 1984, São Paulo (BR)  
▲ Monaco (MC)

## Hobby



Triathlon

## Marital status



Married

## Statistics

### WEC | Le Mans

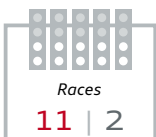

Best grid position<sup>1</sup>

**2<sup>nd</sup>** | **2<sup>nd</sup>**  
4x 2013

Best result

**2<sup>nd</sup>** | **2<sup>nd</sup>**  
3x 2014

## Career highlights

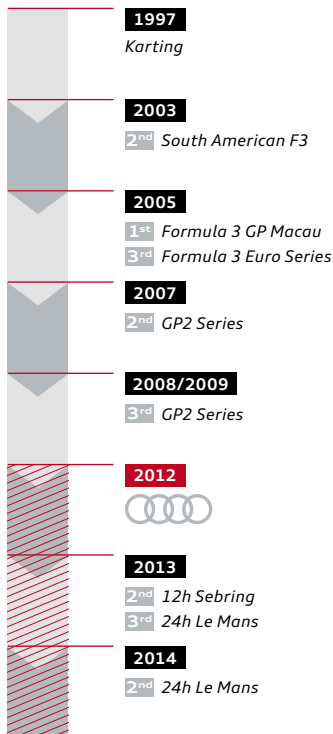

 [lucasdigrassi.com.br](http://lucasdigrassi.com.br)

 [lucasdigrassiofficial](https://www.facebook.com/lucasdigrassiofficial)

 @LucasdiGrassi

<sup>1</sup> Car grid position

WEC



Loïc Duval 

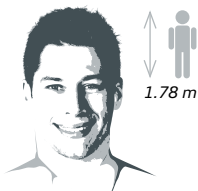

\* June 12, 1982, Chartres (F)  
 ▲ Geneva (CH)

**Hobbies**



**Marital status**



**Statistics**

WEC | Le Mans

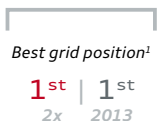
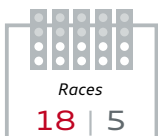

**Career highlights**

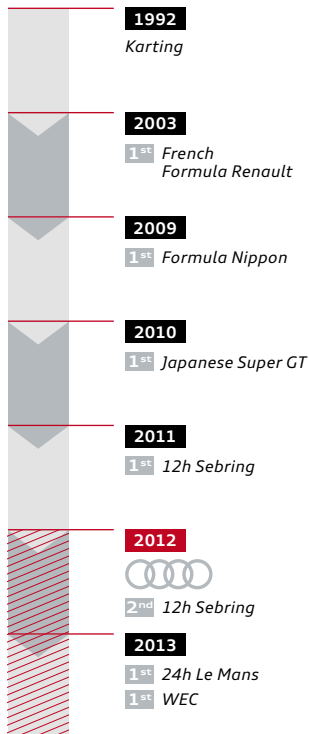

 loicduval.com  
 Loic.Duval.Official  
 @loicduval



# Marcel Fässler



1.78 m

\* May 27, 1976, Einsiedeln (CH)  
▲ Gross (CH)

## Hobbies



Mountain biking



Skiing

## Marital status



Married



4 daughters

## Statistics

### WEC | Le Mans

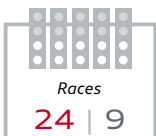

Best grid position<sup>1</sup>

1<sup>st</sup> | 1<sup>st</sup>  
6x | 2x

Best result

1<sup>st</sup> | 1<sup>st</sup>  
8x | 3x

## Career highlights

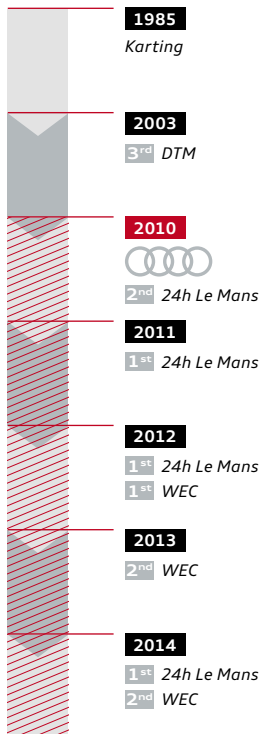

 [marcel-faessler.ch](http://marcel-faessler.ch)

 [pages/Marcel-Faessler/433092060095169](https://www.facebook.com/pages/Marcel-Faessler/433092060095169)

<sup>1</sup> Car grid position



# Oliver Jarvis



1.80 m

\* January 09, 1984, Burwell (GB)

▲ Burwell (GB)

## Hobbies



Soccer



Tennis

## Marital status



Single



1 daughter

## Statistics

### WEC | Le Mans

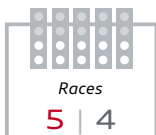

Best grid position<sup>1</sup>  
**2<sup>nd</sup> | 2<sup>nd</sup>**  
3x 2013

Best result  
**3<sup>rd</sup> | 3<sup>rd</sup>**  
4x 2x

## Career highlights

**1997**

Karting

**2005****1<sup>st</sup>** British  
Formula Renault**2006****2<sup>nd</sup>** British F3**2007****1<sup>st</sup>** GP Macau**2008****2012****3<sup>rd</sup>** 24h Le Mans**2013****1<sup>st</sup>** 12h Sebring**3<sup>rd</sup>** 24h Le Mans

 [oliverjarvis.com](http://oliverjarvis.com)

 [olly.jarvis.73](https://www.facebook.com/olly.jarvis.73)

 [@ollyjarvis](https://twitter.com/ollyjarvis)



# André Lotterer



1.84 m

\* November 19, 1981, Duisburg (D)  
▲ Tokyo (J)

## Hobbies



Mountain biking



Single



Cycling

## Marital status

## Statistics

### WEC | Le Mans

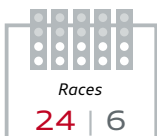

Best grid position<sup>1</sup>

1<sup>st</sup> | 1<sup>st</sup>  
6x | 2x

Best result

1<sup>st</sup> | 1<sup>st</sup>  
8x | 3x

## Career highlights

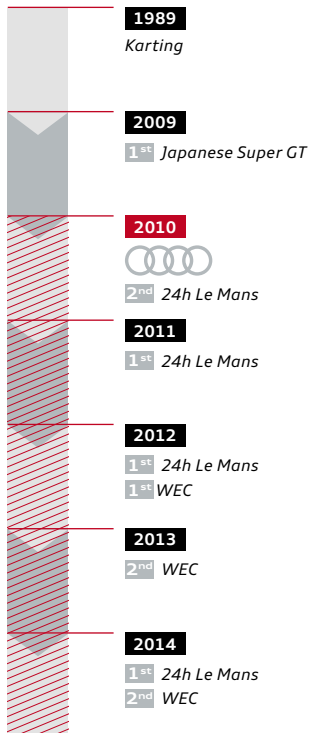

 alotterer

 @andre\_lotterer

<sup>1</sup> Car grid position

WEC



# René Rast

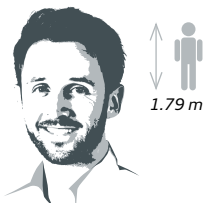

\* October 26, 1986, Minden (D)  
▲ Frankfurt (D)

### Hobbies

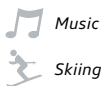

### Marital status



### Statistics

## WEC | Le Mans

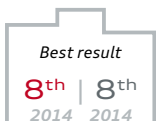
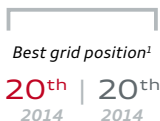
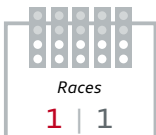

### Career highlights

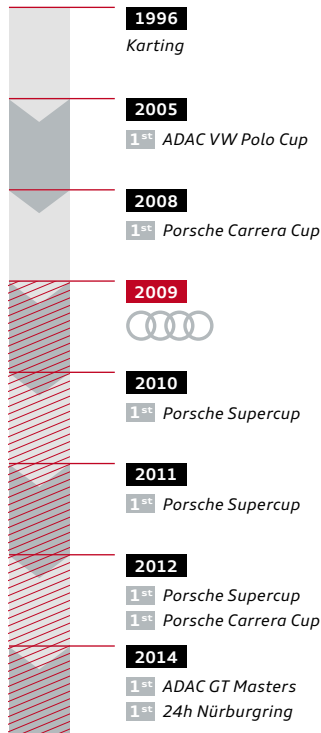

**W** [rene-rast.de](http://rene-rast.de)  
**f** [pages/René-Rast/438204456206325](https://www.facebook.com/pages/René-Rast/438204456206325)  
**T** [@renerastracing](https://twitter.com/renerastracing)





# Benoît Tréluyer



  
1.78 m

\* December 07, 1976, Alençon (F)  
▲ Gordes (F)

## Hobbies



Motocross



Mountain biking

## Marital status



Married



1 son

## Statistics

### WEC | Le Mans

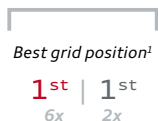
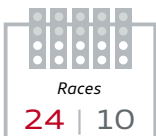

## Career highlights

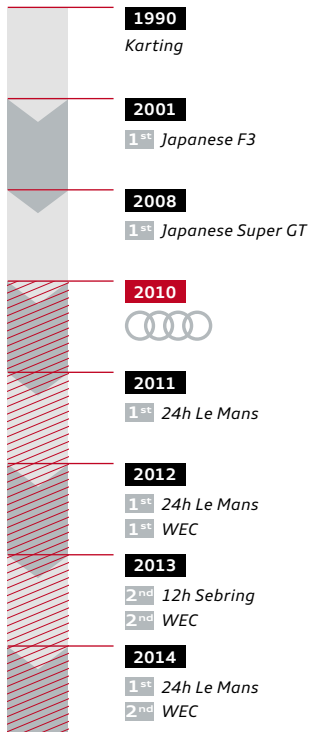

 [benoittréluyer.com](http://benoittréluyer.com)

 [BenoitTreluyer](https://www.facebook.com/BenoitTreluyer)

 [@BenoitTreluyer](https://twitter.com/BenoitTreluyer)

<sup>1</sup> Car grid position

# 1 6h Silverstone, April 12

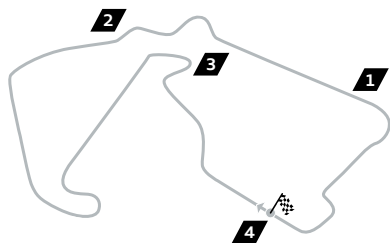

- 1** Top speed 279 km/h
- 2** Fastest corner 275 km/h
- 3** Slowest corner 76 km/h
- 4** Permitted hybrid energy 2,68 MJ

**5.891 km** *Track length*

**approx. 205 km/h**  
*Average speed*

**36** *Gearshifts per lap*

**1m 42.774s**  
*Lap record qualifying*  
Wurz/Nakajima (Toyota), 2014

**1m 42,767s**  
*Lap record race*  
Allan McNish (Audi), 2013

## Audi's WEC track record at Silverstone

<b>3</b> Races	<b>1</b> 1-2 & 1-2-3 finish	<b>1</b> Pole position
<b>2</b> Wins	<b>4</b> Podiums	<b>2</b> Fastest race laps

## Audi market data in Great Britain 2014

- / Delivery volume: 158,800 vehicles
- / Growth rate compared with 2013: 11.8 per cent
- / Delivery volume exceeds 150,000 vehicles for first time
- / Delivery volume more than doubled in ten years



 Silverstone Circuit  
 London

## 2 6h Spa-Francorchamps, May 02

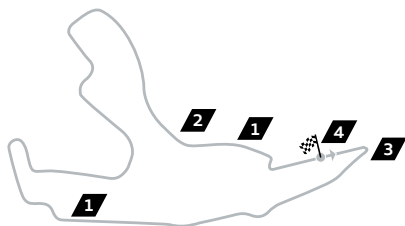

- 1** Top speed 298 km/h
- 2** Fastest corner 290 km/h
- 3** Slowest corner 66 km/h
- 4** Permitted hybrid energy 3,19 MJ

**7.004 km** Track length

**approx. 215 km/h**  
Average speed

**48** Gearshifts per lap

**1m 57.884s**  
Lap record qualifying  
Sébastien Bourdais (Peugeot), 2010

**1m 59.797s**  
Lap record race  
Franck Montagny (Peugeot), 2010

### Audi's WEC track record at Spa-Francorchamps

<b>3</b> Races	<b>2</b> 1-2 & 1-2-3 finishes	<b>2</b> Pole positions
<b>2</b> Wins	<b>7</b> Podiums	<b>2</b> Fastest race laps

### Audi market data in Belgium 2014

- / Delivery volume: 31,800 vehicles
- / Growth rate compared with 2013: 5 per cent
- / Audi A3<sup>1</sup> top-selling model and leading in its segment
- / Manufacturing location: Brussels



 Circuit de Spa-Francorchamps  
 Brussels

<sup>1</sup>Please refer to the list on page 151 for the consumption and emission values

## 3 24h Le Mans, June 13–14

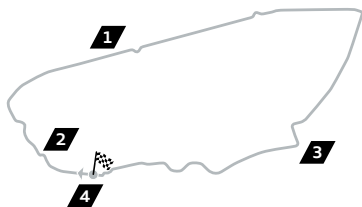

- 1** Top speed 324 km/h
- 2** Fastest corner 278 km/h
- 3** Slowest corner 76 km/h
- 4** Permitted hybrid energy 4,00 MJ

**13.629 km** *Track length*

**approx. 245 km/h**  
*Average speed*

**72** *Gearshifts per lap*

**3m 18.513s**  
*Lap record qualifying*  
Stéphane Sarrazin (Peugeot), 2008

**3m 19.074s**  
*Lap record race*  
Loïc Duval (Peugeot), 2010

### Site map

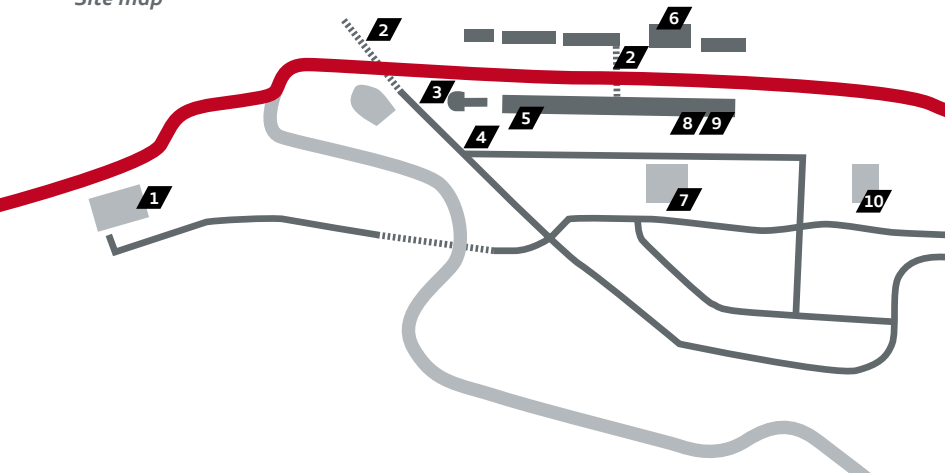

### Audi's WEC track record at Le Mans

<b>3</b> Races	<b>2</b> 1-2 & 1-2-3 finishes	<b>2</b> Pole positions
<b>3</b> Wins	<b>7</b> Podiums	<b>3</b> Fastest race laps

### Audi market data in France 2014

- / Delivery volume: 57,200 vehicles
- / Growth rate compared with 2013: 0.4 per cent
- / Audi market leader with A1<sup>1</sup>, A3, Q3<sup>1</sup> and Q5<sup>1</sup>

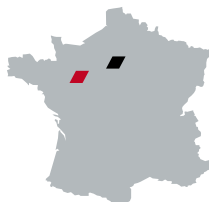

■ Circuit des 24 Heures  
■ Paris

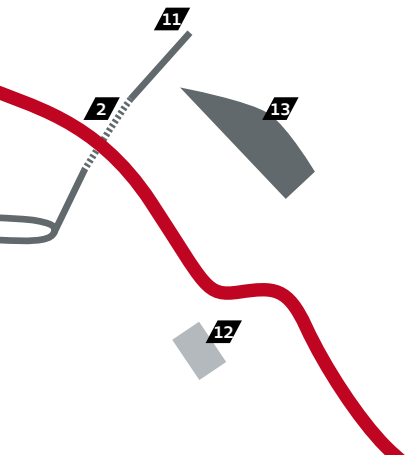

### Key

- 1** Audi Racing Arena, Audi Press Conference, (Parc du Raccordement)
- 2** Tunnel
- 3** Race direction
- 4** Paddock entrance
- 5** Media Center
- 6** Audi Racing Club
- 7** Audi Team and Media Hospitality (paddock)
- 8** Audi Sport Team Joest, Pit 44, 45, 46
- 9** Audi Racing Lounges, No. 142/143, 145/146
- 10** Audi Racing Garden, Audi Racing Shop, Audi Tower
- 11** Circuit entrance
- 12** Audi Fan Area
- 13** Museum

<sup>1</sup> Please refer to the list on page 151 for the consumption and emission values

## 4 6h Nürburgring, August 30

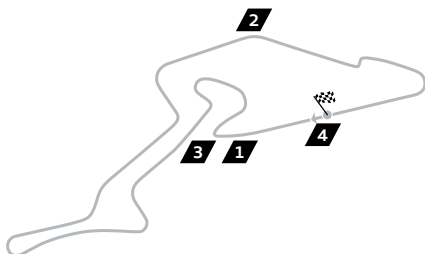

- 1** Top speed 275 km/h
- 2** Fastest corner 230 km/h
- 3** Slowest corner 72 km/h
- 4** Permitted hybrid energy 2,34 MJ

**5.148 km** Track length

**approx. 185 km/h<sup>1</sup>**  
Average speed

**70** Gearshifts per lap

**1m 39.492s<sup>1</sup>**

Lap record qualifying  
Gené/Minassian (Peugeot), 2008

**1m 40.501s<sup>1</sup>**

Lap record race  
Gené/Minassian (Peugeot), 2008

### Audi's WEC track record at the Nürburgring

- Races
- 1-2 & 1-2-3 finishes
- Pole positions
- Wins
- Podiums
- Fastest race laps

### Audi market data in Germany 2014

- / Delivery volume: 255,600 vehicles
- / Growth rate compared with 2013: 2.2 per cent
- / Audi premium market leader
- / Audi A3, Q5 and A6<sup>2</sup> leading in their segment
- / Manufacturing locations: Ingolstadt, Neckarsulm



-  Nürburgring
-  Berlin

<sup>1</sup> Le Mans Series (track length: 5.137 km)

<sup>2</sup> Please refer to the list on page 151 for the consumption and emission values

## 5 6h Austin, September 19

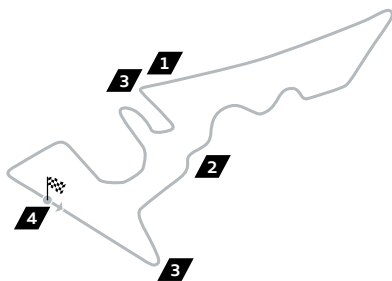

- 1** Top speed 286 km/h
- 2** Fastest corner 251 km/h
- 3** Slowest corner 68 km/h
- 4** Permitted hybrid energy 2,51 MJ

**5.513 km** Track length

**approx. 180 km/h**  
Average speed

**58** Gearshifts per lap

**1m 48.355s**  
Lap record qualifying  
Duval/McNish (Audi), 2013

**1m 47.375s**  
Lap record race  
Benoît Tréluyer (Audi), 2013

### Audi's WEC track record in Austin

<b>2</b> Races	<b>1</b> 1-2 & 1-2-3 finish	<b>1</b> Pole position
<b>2</b> Wins	<b>4</b> Podiums	<b>1</b> Fastest race lap

### Audi market data in the USA 2014

- / Delivery volume: 182,000 vehicles
- / Growth rate compared with 2013: 15.2 per cent
- / Audi Q5 best-selling model
- / Audi is the fastest growing European premium brand
- / Audi records fifth record year in succession

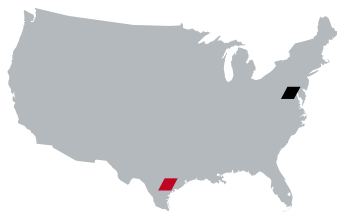

-  Circuit of The Americas
-  Washington D. C.

## 6 6h Fuji, October 11

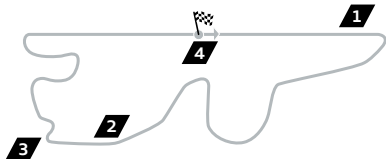

- 1** Top speed 301 km/h
- 2** Fastest corner 251 km/h
- 3** Slowest corner 66 km/h
- 4** Permitted hybrid energy 2,08 MJ

**4.563 km** Track length

**approx. 190 km/h**  
Average speed

**44** Gearshifts per lap

**1m 26.577s**  
Lap record qualifying  
Lotterer/Tréluyer (Audi), 2013

**1m 27.759s**  
Lap record race  
Mark Webber (Porsche), 2014

### Audi's WEC track record at Fuji

<b>3</b> Races	<b>0</b> 1-2 & 1-2-3 finishes	<b>1</b> Pole position
<b>0</b> Wins	<b>2</b> Podiums	<b>1</b> Fastest race lap

### Audi market data in Japan 2014

- / Delivery volume: 31,400 vehicles
- / Growth rate compared with 2013: 9.1 per cent
- / Delivery volume exceeds 30,000 vehicles for first time
- / Delivery volume has grown every year since 2007 and has doubled to date



 Fuji Speedway  
 Tokyo



## 7 6h Shanghai, November 01

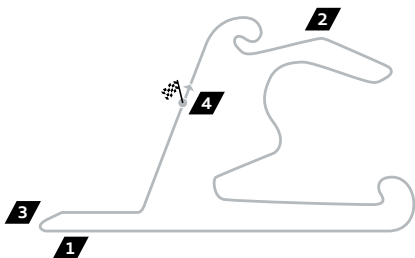

- 1** Top speed 299 km/h
- 2** Fastest corner 235 km/h
- 3** Slowest corner 56 km/h
- 4** Permitted hybrid energy 2,48 MJ

**5.451 km** Track length

**approx. 180 km/h**  
Average speed

**46** Gearshifts per lap

**1m 48.013s**  
Lap record qualifying  
Lapierre/Wurz (Toyota), 2013

**1m 48.694s**  
Lap record race  
Sébastien Buemi (Toyota), 2014

### Audi's WEC track record in Shanghai

<b>3</b> Races	<b>0</b> 1-2 & 1-2-3 finishes	<b>0</b> Pole positions
<b>1</b> Win	<b>3</b> Podiums	<b>1</b> Fastest race lap

### Audi market data in China 2014

- / Delivery volume: 578,900 vehicles
- / Growth rate compared with 2013: 17.7 percent
- / Audi A6 L best-selling model
- / Audi is the first premium manufacturer to make more the 500,000 deliveries
- / Manufacturing locations: Changchun, Foshan



 Shanghai International Circuit  
 Beijing

## 8 6h Bahrain, November 21

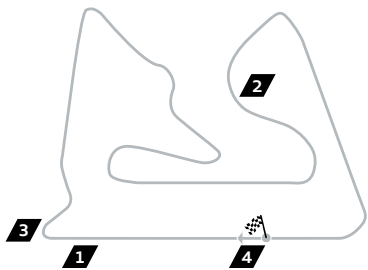

- 1** Top speed 293 km/h
- 2** Fastest corner 202 km/h
- 3** Slowest corner 61 km/h
- 4** Permitted hybrid energy 2,46 MJ

**5.412 km** Track length

**approx. 190 km/h**  
Average speed

**58** Gearshifts per lap

**1m 42.449s**  
Lap record qualifying  
Wurz/Nakajima (Toyota), 2013

**1m 44.183s**  
Lap record race  
André Lotterer (Audi), 2013

### Audi's WEC track record in Bahrain

<b>3</b> Races	<b>1</b> 1-2 & 1-2-3 finish	<b>1</b> Pole position
<b>1</b> Win	<b>3</b> Podiums	<b>1</b> Fastest race lap

### Audi market data in the Middle East 2014

- / Delivery volume: 11,130 vehicles
- / Growth rate compared with 2013:  
5 per cent (record)
- / Delivery volume has almost doubled since 2010
- / Audi Q7<sup>1</sup> best-selling model



 Bahrain International Circuit  
 Manama

# Every winner of the 24h Le Mans

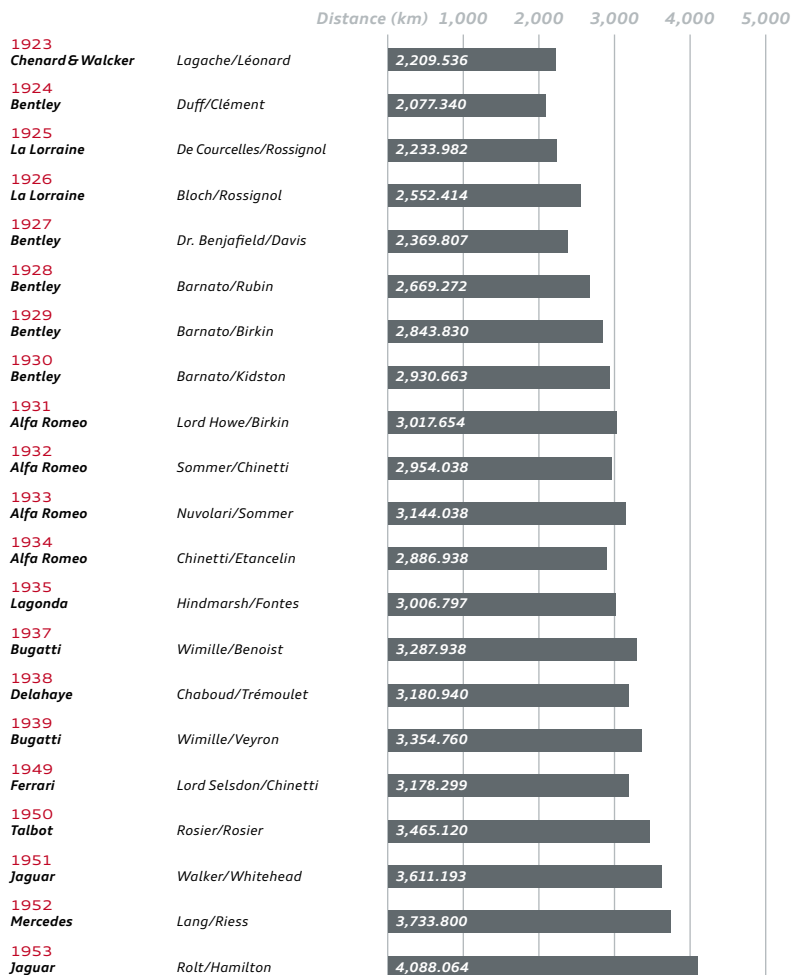

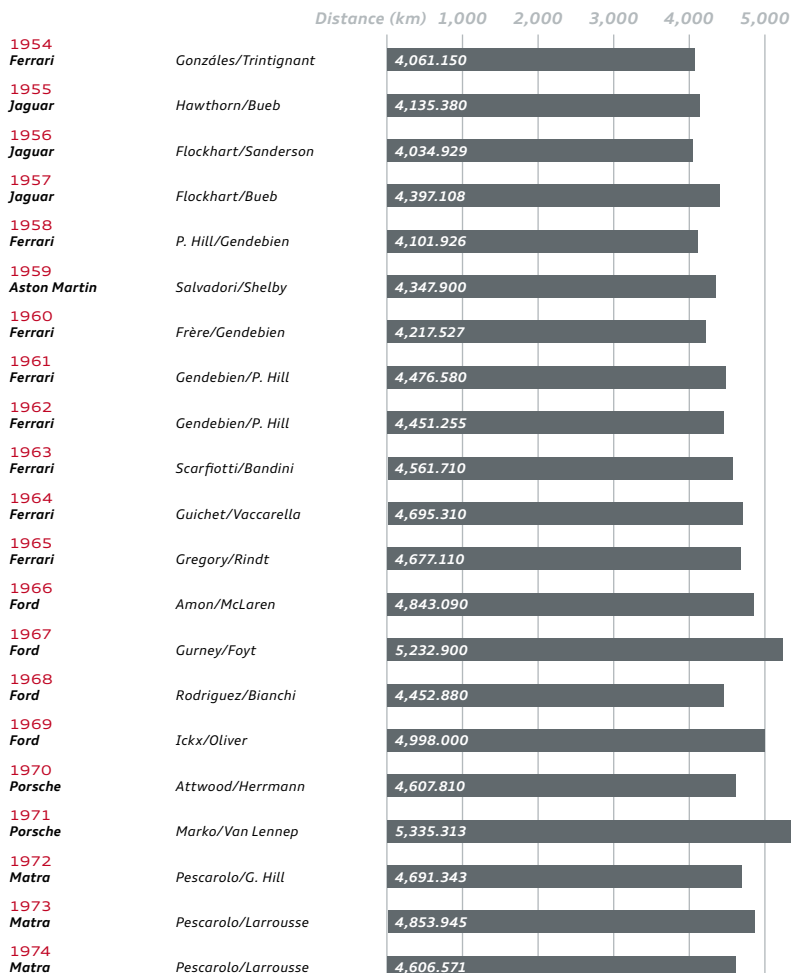

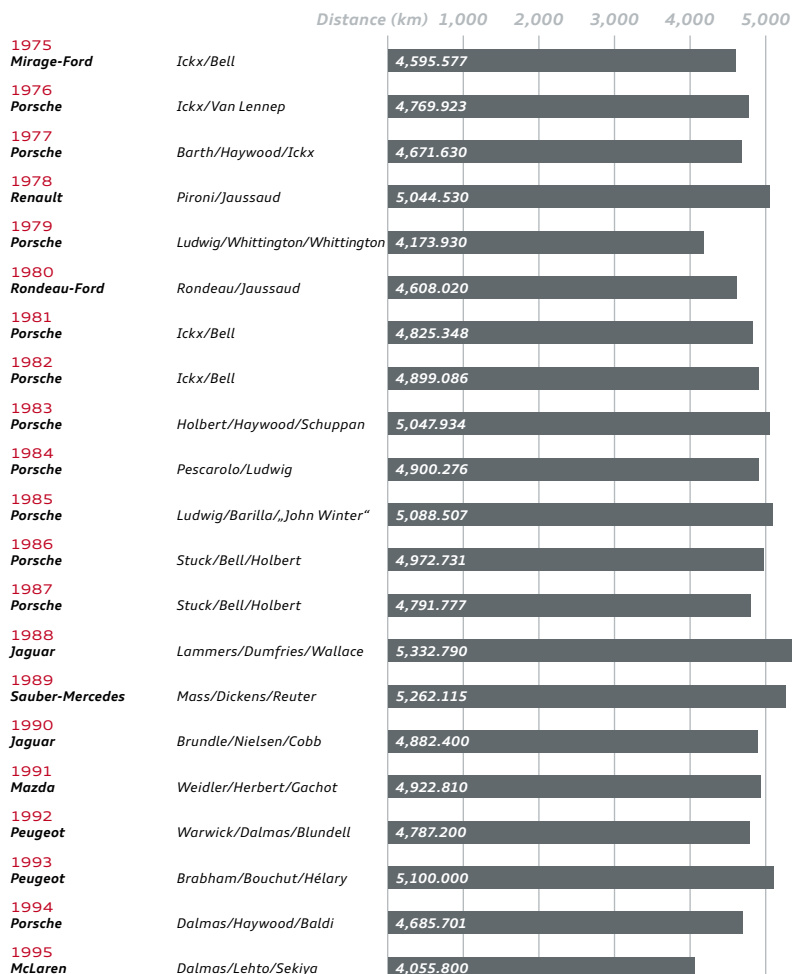

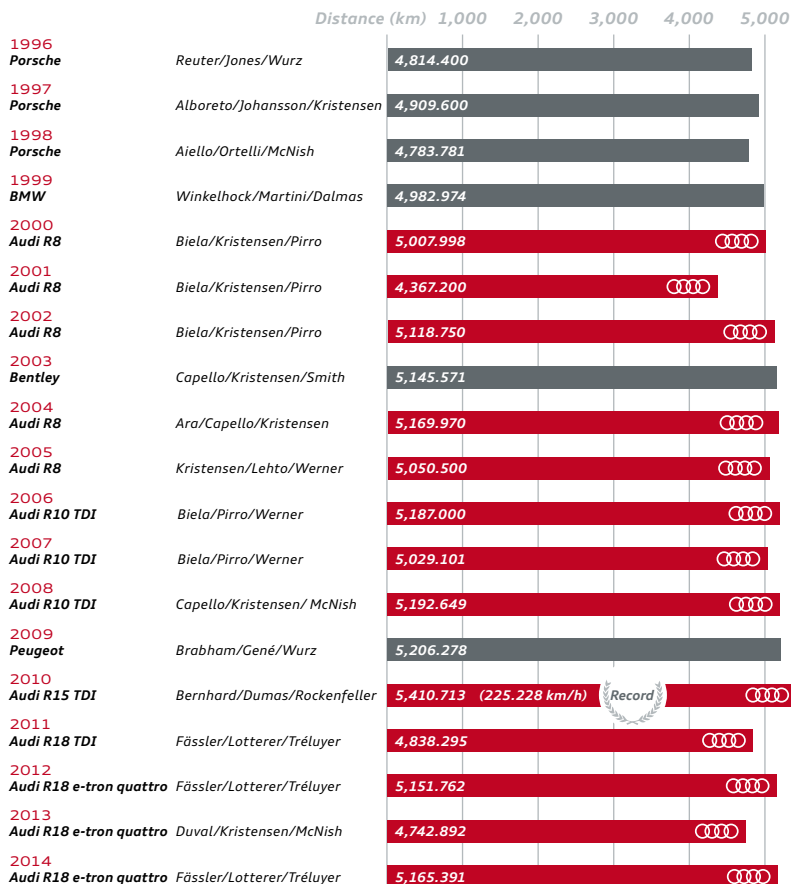

# All 14 circuit versions ever used for the 24h Le Mans

1929 16.340 km

1979 13.626 km  
2007 13.629 km

1932 13.492 km  
2002 13.650 km

1956 13.461 km  
1987 13.535 km  
1997 13.605 km  
2006 13.650 km

1968 13.469 km





1972 13.640 km

1990 13.600 km

..... 1923 17.262 km  
■ 2007-2015 13.629 km  
● Modifications

1986 13.528 km

## Audi's LMP titles and great endurance race victories

Championships/ single races	 Audi R8	 Audi R10 TDI	 Audi R15 TDI	 Audi R18 TDI <sup>1</sup> / e-tron quattro <sup>2</sup>
WEC (2)				● ● 2012–2013 <sup>2</sup>
ALMS (9)	● ● ● ● ● ● ● ● ● 2000–2006 <sup>1</sup>	● ● ● 2006 <sup>1</sup> –2008		
ELMS (3)	● ● 2001, 2004	● 2008		
24h Le Mans (13)	● ● ● ● ● 2000–2002 2004–2005	● ● ● 2006–2008	● 2010	● ● ● ● 2011 <sup>1</sup> 2012–2014 <sup>2</sup>
12h Sebring (11)	● ● ● ● ● ● ● ● ● ● ● 2000–2005	● ● 2006–2007	● 2009	● ● 2012 <sup>1</sup> 2013 <sup>2</sup>
„Petit Le Mans“ (9)	● ● ● ● ● ● ● ● ● 2000–2005	● ● ● ● 2006–2008		



# Every victory for Audi's LMP race cars 1999–2014

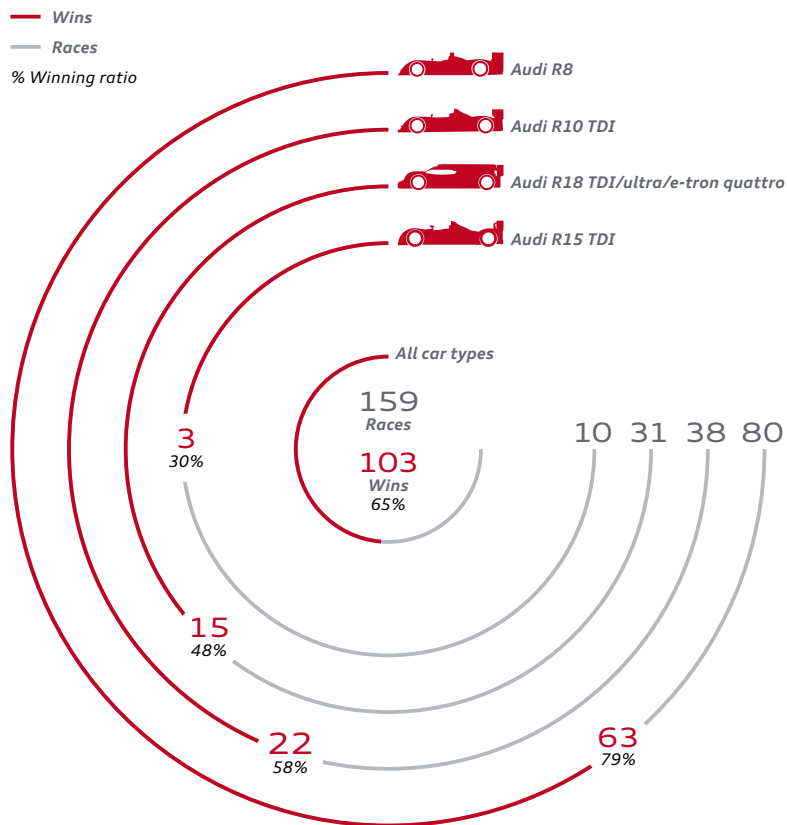

## Partners of Audi Sport in the WEC



## Other partners



*alpinestars.com*



*gerolsteiner.com*



*oz-racing.de*

**Audi**  
**Top Service®**

*audi.com*



*hofmuehl.de*



**DTM**

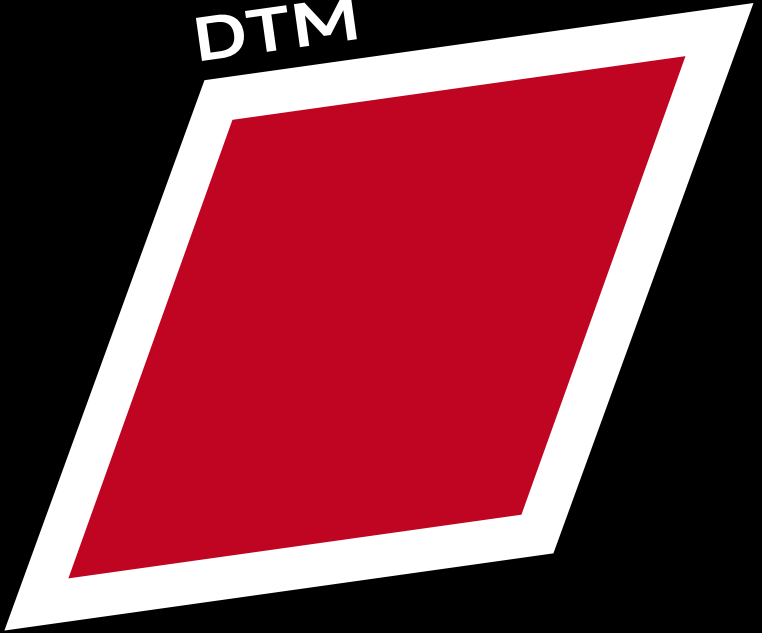



# Contents

---

Audi RS 5 DTM: safety elements .....	76
Drag Reduction System (DRS) .....	78
A glance in the RS 5 DTM cockpit .....	80
DTM race weekend format .....	82
Every DTM year .....	84
The average DTM Champion .....	85
Key personnel in the DTM program .....	86
Teams and drivers .....	88
Audi Sport Team Abt Sportsline .....	89
Audi Sport Team Phoenix .....	90
Audi Sport Team Rosberg .....	91
The eight drivers – a quick profile .....	92
The tracks – a summary .....	100
Titles and victories in the DTM .....	109
Best Audi drivers each season .....	110
Winning ratio by car .....	111
Partners of Audi Sport in the DTM .....	112

## Audi RS 5 DTM: safety elements

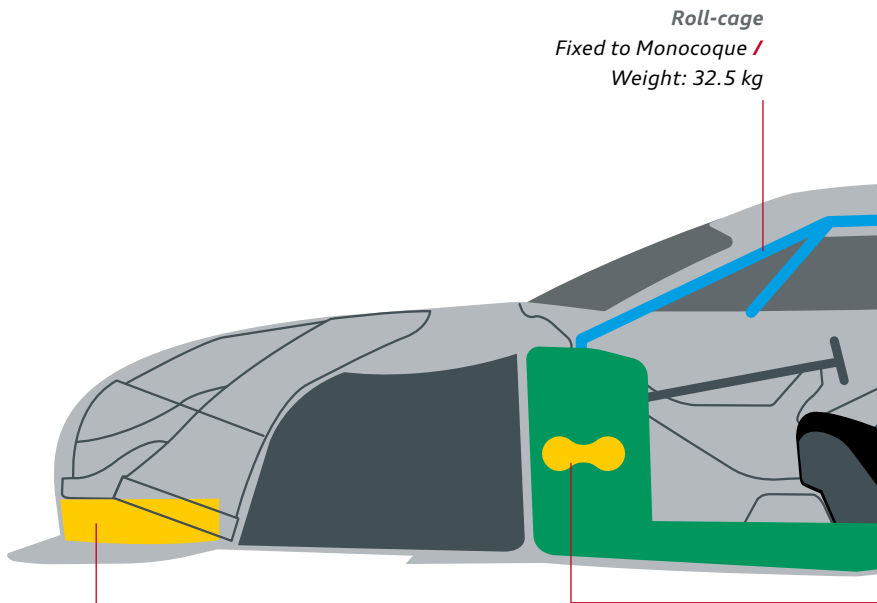

**Roll-cage**  
*Fixed to Monocoque /  
Weight: 32.5 kg*

**Crash box, front**

*In a frontal impact at 54 km/h, the driver's chest must only be subject to a maximum load of 60 g*



### **Monocoque**

*Manufactured entirely from  
Carbon / Weight: 126 kg /  
120 liter fuel tank integrated*

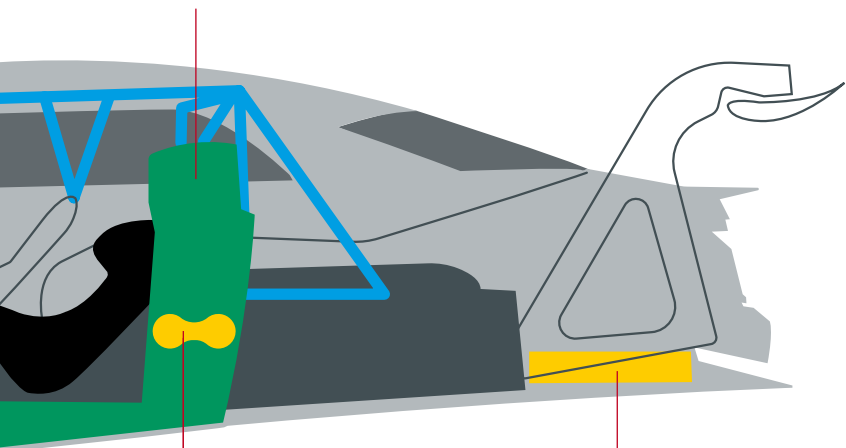

### **Crash boxes, lateral**

*Complete side panel must withstand a force of 360 kN in the side impact test – this equals 36 tons*

### **Crash box, rear**

*Length: 65 cm (as front) / Must survive a crash test against a solid wall at a speed of about 50 km/h*

## Drag Reduction System (DRS)

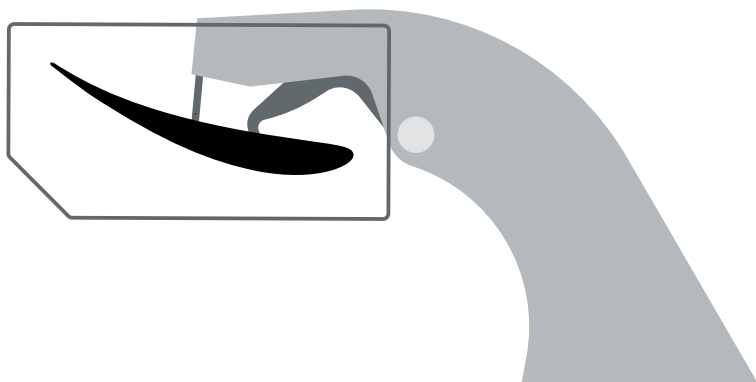
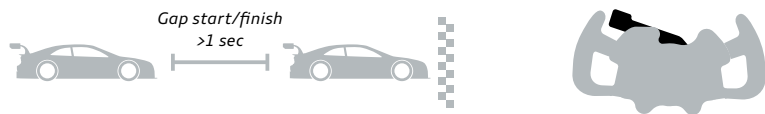

- / Movable rear wing in normal position
- / Greater air resistance generates downforce in the corners
- / Distance to car in front is measured at start/finish
- / If the interval is greater than one second: DRS disabled

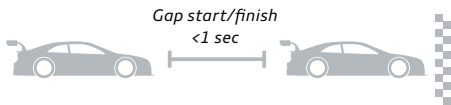

✦ 18° Rear wing angle reduction

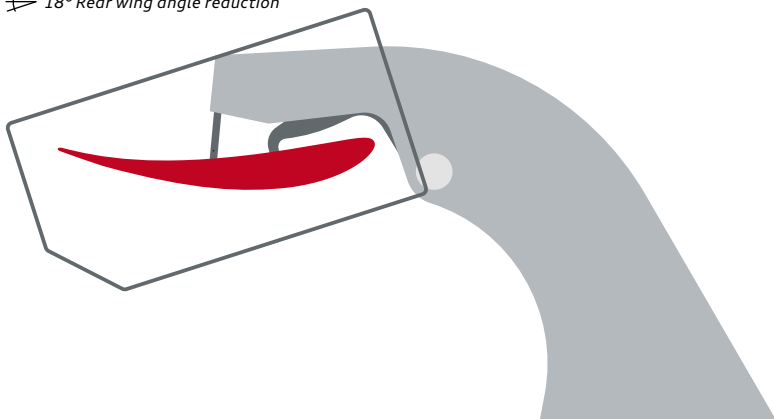

- / If the interval is less than one second: DRS enabled
- / DRS can be used up to three times during the following lap
- / Activation is made by pulling a lever on the steering wheel
- / The top speed increases on the straights owing to a reduction in drag

## A glance in the RS 5 DTM cockpit

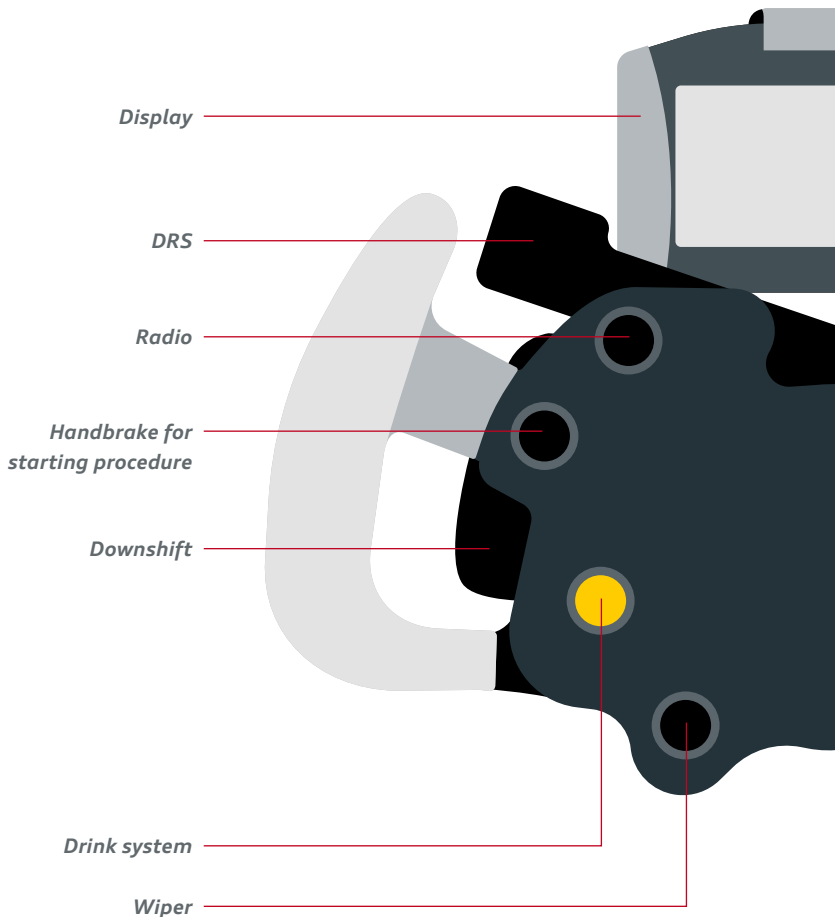

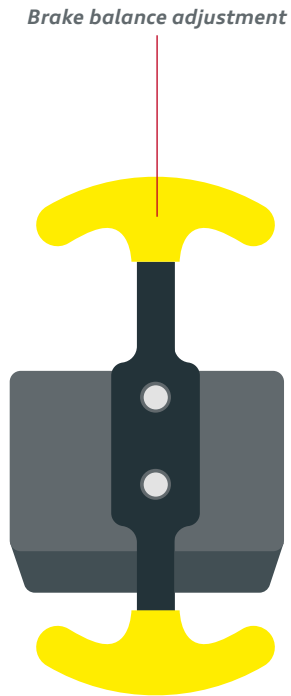
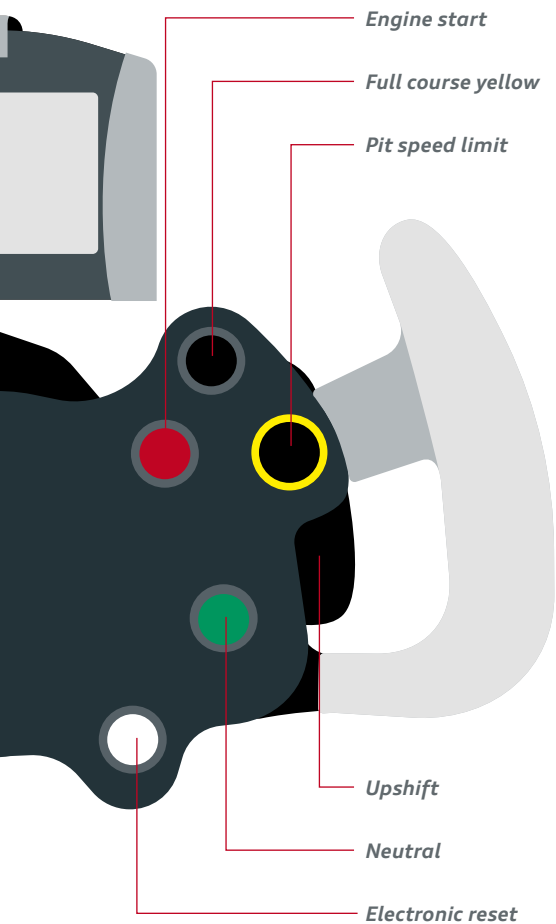

# DTM race weekend format

## Qualifying (for each race)

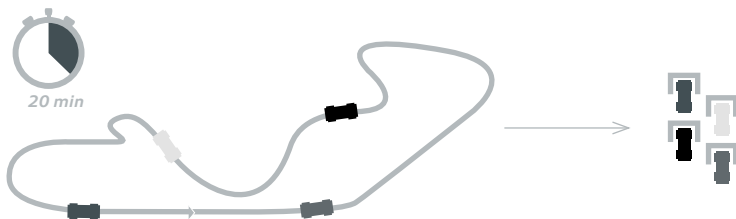

## Race 1 (Saturday)

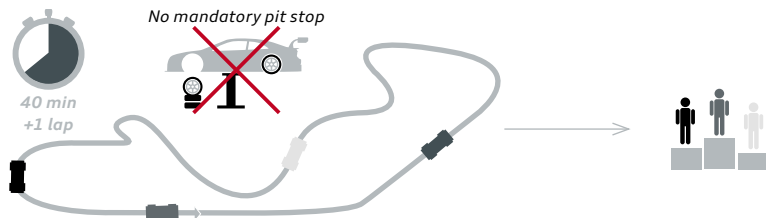

## Race 2 (Sunday)

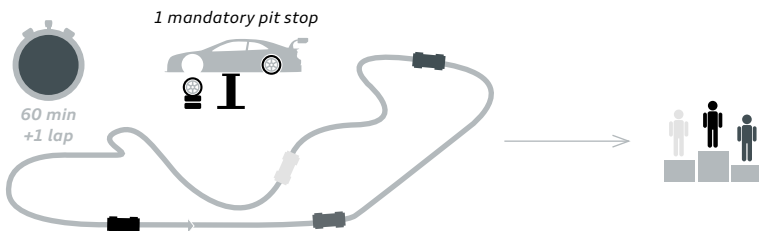

## Other rules

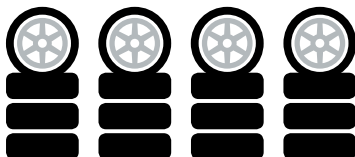

### Tires

Four sets of slicks per car per weekend for qualifying and races



### Performance weights

Subject to the finishing positions of the drivers, the total weight of every car from each manufacturer is adjusted individually for the following race: increased, reduced or it remains unchanged

## Titles



Driver



Team



Manufacturer

## Important links

**DMSB**

 [dmsb.de](http://dmsb.de)

**DTM #DTM**

 [dtm.com](http://dtm.com)

 [DTM](#)

 [@dtm](#)

## Points scoring system

1 <sup>st</sup> place	2 <sup>nd</sup> place	3 <sup>rd</sup> place	4 <sup>th</sup> place	5 <sup>th</sup> place
25	18	15	12	10
6 <sup>th</sup> place	7 <sup>th</sup> place	8 <sup>th</sup> place	9 <sup>th</sup> place	10 <sup>th</sup> place
8	6	4	2	1

### Audi Sport

[#AudiSport](#) [#DTM](#)  
[#welcomechallenges](#)

 [audi-motorsport.com](http://audi-motorsport.com)

 [AudiSport](#)

 [@Audi\\_\\_Sport](#)

# Every DTM year

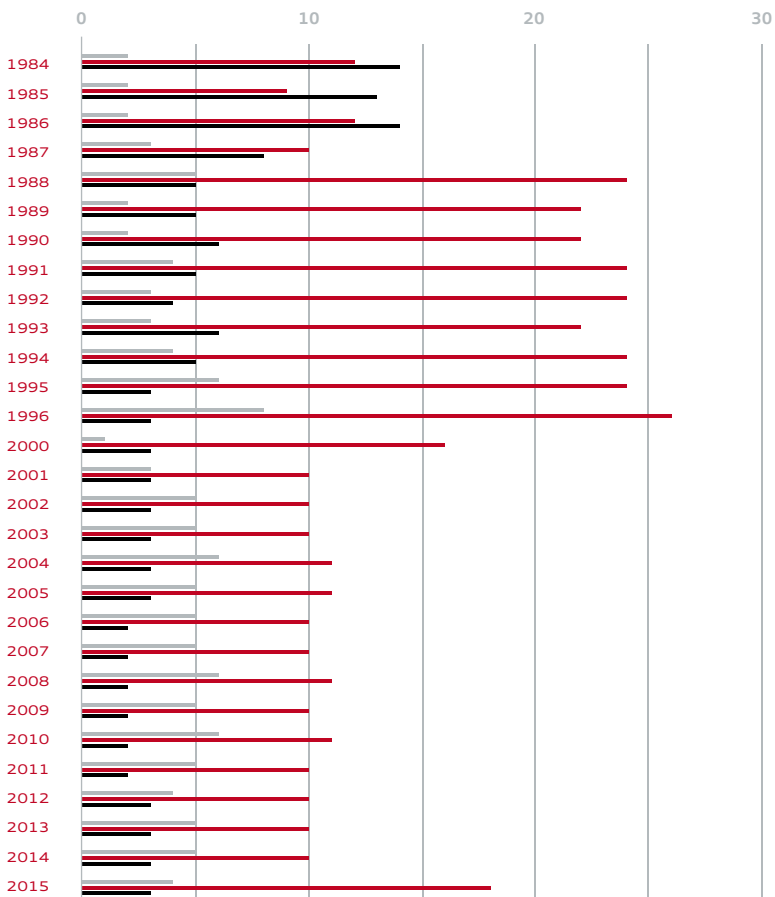

— Host countries

— Races

— Competing manufacturers



# The average DTM Champion ...

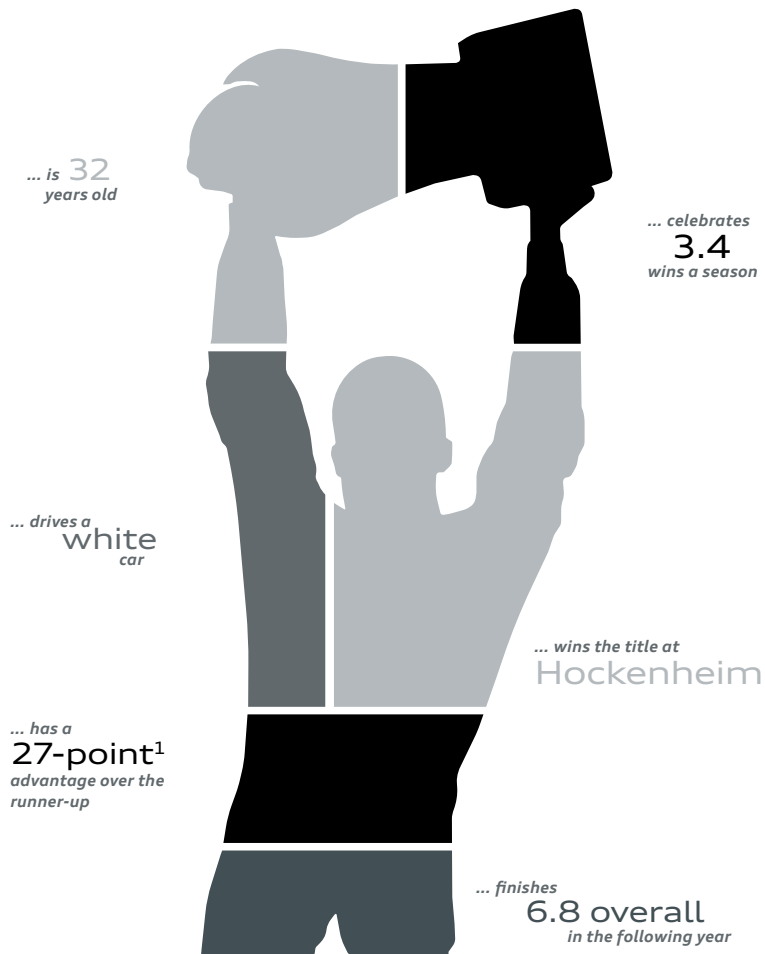

<sup>1</sup> Calculated using the current points scoring system

## Key personnel in the DTM program



*Dieter Gass  
Head of DTM*



*Stefan Gugger  
Project Manager  
Vehicle Development*



*Jürgen Hofbauer  
Technical Coordinator*



*Dr. Andrea Milocco  
Project Manager Engine*



*Florian Modlinger  
Project Manager Test & Technology*



*Volker Nossek  
Project Manager Organization*



*Oliver Straube  
Partnerships*

## Audi Sport Team Abt Sportsline



*Hans-Jürgen Abt*  
*Team Director*



*Harry Unflath*  
*Head of Marketing*



*Thomas Biermaier*  
*Sport Director*



*Michael Seifert*  
*Team Manager*

## Audi Sport Team Phoenix



*Ernst Moser*  
*Team Director*



*Chris van Rutten*  
*Head of Technology*



*Dirk Theimann*  
*Team Manager*

## Audi Sport Team Rosberg



*Arno Zensen*  
*Team Director*



*Ossi Oikarinen*  
*Technical Director*



*Kimmo Liimatainen*  
*Team Manager*



*Ramon Hämmerle*  
*Team Coordinator*

## Teams and drivers

### Audi Sport Team Abt Sportsline

 **EKS**  
Mattias Ekström

Florian Modlinger  
Car engineer





**#5**  
Red Bull Audi RS 5 DTM

 **MOL**  
Miguel Molina



Markus Michelberger  
Car engineer



**#17**  
Teufel Audi RS 5 DTM

 **TAM**  
Adrien Tambay

Nicola Palarchi  
Car engineer

**#27**  
Playboy Audi RS 5 DTM

 **MOR**  
Edoardo Mortara

Franco Chiochetti  
Car engineer



**#48**  
Castrol EDGE Audi RS 5 DTM

### Audi Sport Team Phoenix

 **TSC**  
Timo Scheider

Laurent Fedacou  
Car engineer



**#10**  
AUTO TEST Audi RS 5 DTM

 **ROC**  
Mike Rockenfeller

Jürgen Jungklaus  
Car engineer



**#99**  
Schaeffler Audi RS 5 DTM

### Audi Sport Team Rosberg

 **MUE**  
Nico Müller

Karl Jennings  
Car engineer



**#51**  
Audi Financial Services Audi RS 5 DTM

 **GRE**  
Jamie Green

Erich Baumgärtner  
Car engineer



**#53**  
Hoffmann Group Audi RS 5 DTM

# Audi Sport Team Abt Sportsline

1991

Founded

Since 1996

Partner of Audi

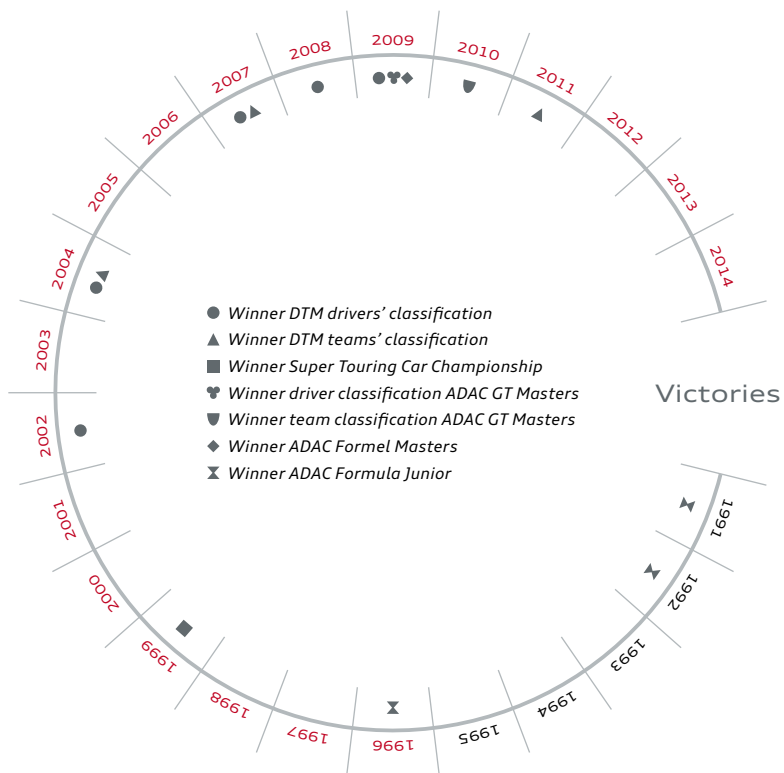

# Audi Sport Team Phoenix

1999

Founded

Since 2006

Partner of Audi

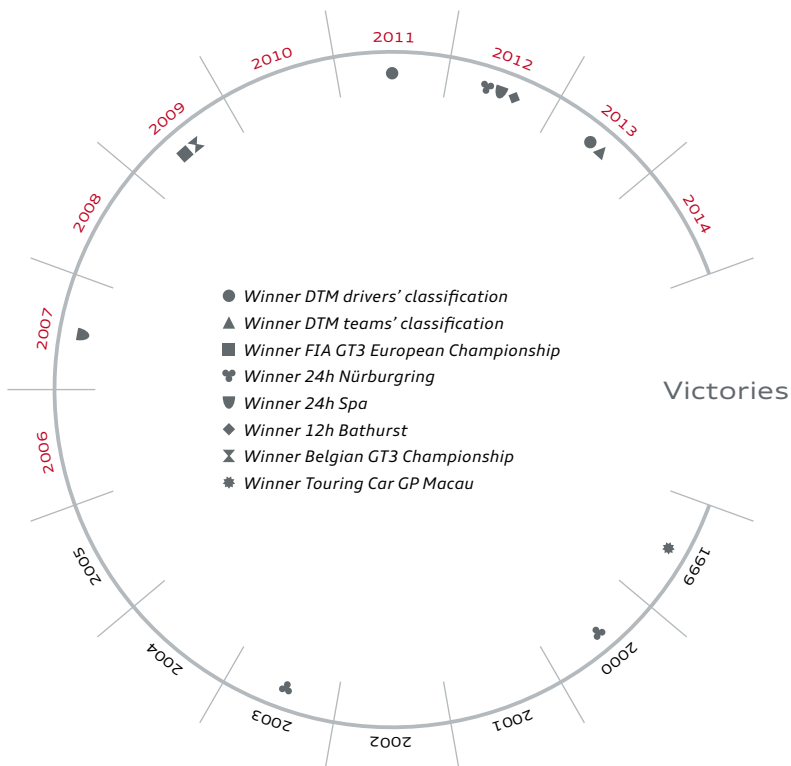

# Audi Sport Team Rosberg

**1994**  
Founded

**Since 2006**  
Partner of Audi

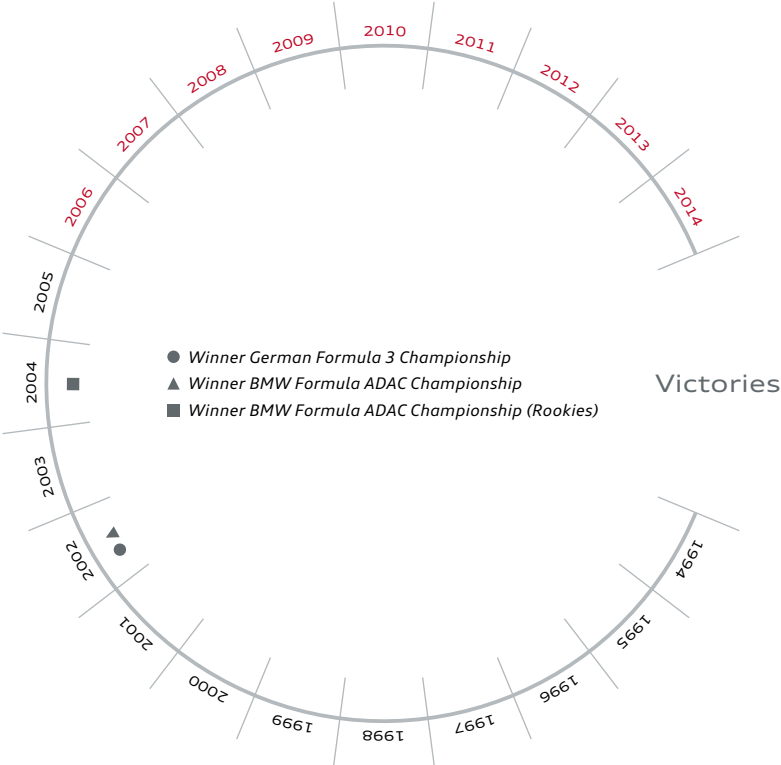



# #5 Mattias Ekström



1.83 m

\* July 14, 1978, Falun (S)  
 ▲ Going (A)

## Hobbies



Cycling

Skiing

## Marital status

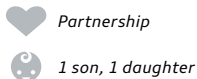

Partnership

1 son, 1 daughter

## Statistics DTM

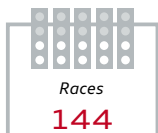



Best grid position

**1<sup>st</sup>**  
 19x

Best result

**1<sup>st</sup>**  
 19x

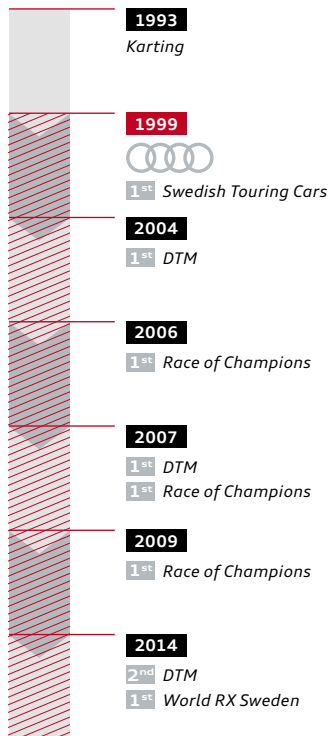
## Career highlights

 [mattiasekstromracing](#)
 [mattiasekstrom.com](#)
 [mattiasekstrom.racing](#)
 [@mattiasekstroem](#)





# #53 Jamie Green



  
1.78 m

\* June 14, 1982, Leicester (GB)  
▲ Monaco (MC)

## Hobbies



Soccer



Golf

## Marital status



Married



2 sons

## Statistics DTM

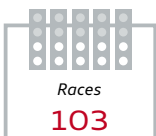

Best grid position

**1<sup>st</sup>**  
7x

Best result

**1<sup>st</sup>**  
8x

## Career highlights

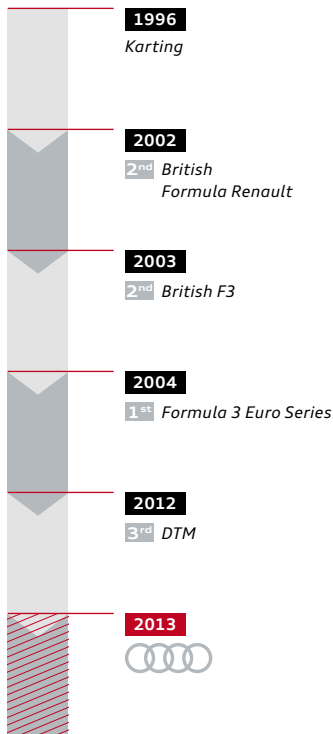

 [jamiegreenracing.co.uk](http://jamiegreenracing.co.uk)

 @JamieGreen\_

DTM



# #17 Miguel Molina



1.75 m

\* February 17, 1989, Barcelona (E)  
▲ Lloret de Mar (E)

## Hobby



Slotcars

## Marital status



Partnership

## Statistics DTM

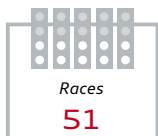

Best grid position

**1<sup>st</sup>**  
3x

Best result

**2<sup>nd</sup>**  
2014

## Career highlights

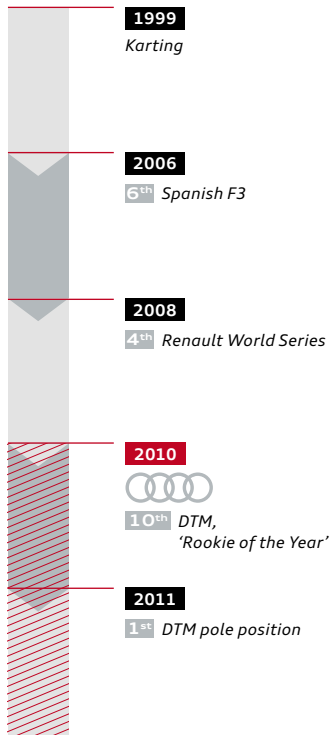

 [miguelmolina.net](http://miguelmolina.net)

 [Miguel.Molina.racing](https://www.facebook.com/Miguel.Molina.racing)

 [@MiguelMolinaM2](https://twitter.com/MiguelMolinaM2)



# #48 Edoardo Mortara



1.82 m

\* January 12, 1987, Geneva (CH)

▲ Geneva (CH)

## Hobbies



Skiing



Wakeboarding

## Marital status



Married

## Statistics DTM



Best grid position

1<sup>st</sup>  
2012

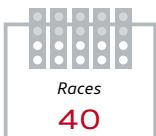

Best result

1<sup>st</sup>  
2x

## Career highlights

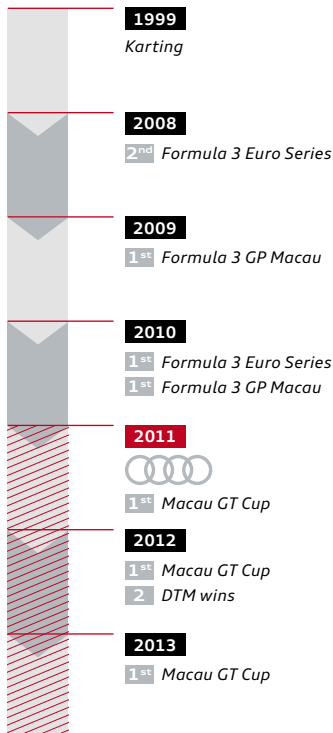

 edomortara

 edoardomortara.com

 edomortararacing

 @edomortara

DTM



# #51 Nico Müller



1.85 m

\* February 25, 1992, Thun (CH)

▲ Bern (CH)

## Hobbies



Karting



Cycling

## Marital status



Partnership

## Statistics DTM

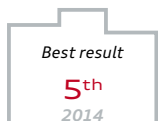
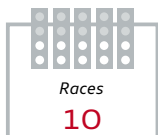

## Career highlights

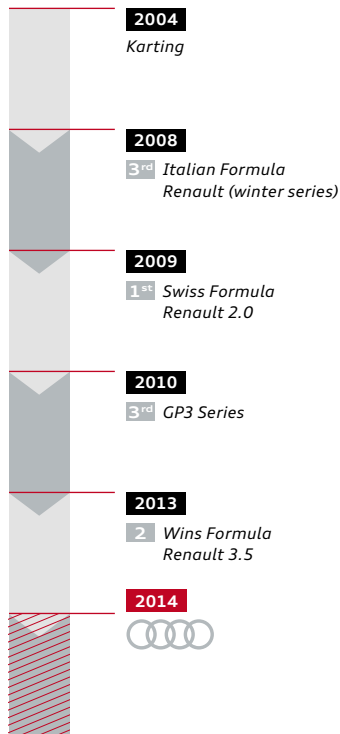

 [nicosmueller](#)

 [nicomueller.ch](#)

 [NicoMuellerOfficial](#)

 [@nico\\_mueller](#)



# #99 Mike Rockenfeller



1.75 m

\* October 31, 1983, Neuwied (D)  
▲ Landschlacht (CH)

## Hobbies

 Historic cars

 Cycling

## Marital status

 Married

 1 son

## Statistics DTM

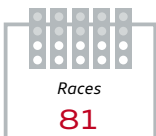



Best grid position  
**1<sup>st</sup>**  
4x

Best result  
**1<sup>st</sup>**  
3x

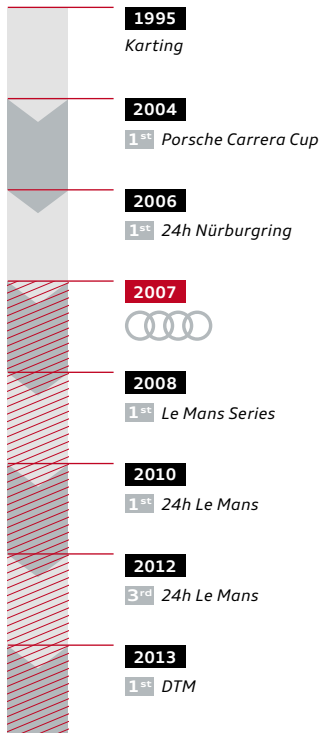
## Career highlights



 [mike\\_rockenfeller](#)

 [mike-rockenfeller.de](#)

 [mikerockenfeller](#)

 [@m\\_rockenfeller](#)

DTM



# #10 Timo Scheider



1.78 m

\* November 10, 1978, Lahnstein (D)  
▲ Lochau (A)

## Hobbies



Family



Karting

## Marital status



Engaged



1 son

## Statistics DTM



Best overall finish

**1<sup>st</sup>**  
2x

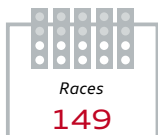

Races

**149**

Best grid position

**1<sup>st</sup>**  
11x

Best result

**1<sup>st</sup>**  
6x

## Career highlights

**1989**

Karting

**1995**

**1<sup>st</sup>** German Formula Renault 1800

**1997**

**2<sup>nd</sup>** German F3

**2003**

**1<sup>st</sup>** 24h Nürburgring

**2005**

**2<sup>nd</sup>** FIA GT  
**1<sup>st</sup>** 24h Spa

**2006**



**2008**

**1<sup>st</sup>** DTM

**2009**

**1<sup>st</sup>** DTM

 [timoscheider.de](http://timoscheider.de)

 [scheider](https://www.facebook.com/scheider)



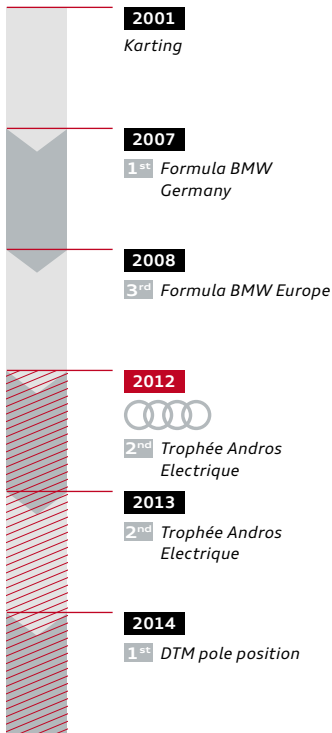

# #27 Adrien Tambay

## Career highlights



 [adrientambay](#)

 [adrientambay.com](#)

 [adrientambayofficial](#)

 [@TambayRacing](#)



 1.81 m

\* February 25, 1991, Paris (F)  
▲ London (GB)

## Hobbies

 Family

 Fitness

## Marital status

 Single

## Statistics DTM

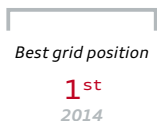
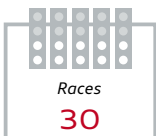

# 1 Hockenheim, May 02–03

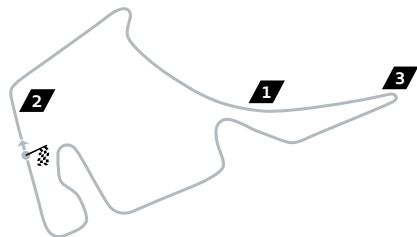

- 1** Top speed 258 km/h
- 2** Fastest corner 180 km/h
- 3** Slowest corner 65 km/h

**4.574 km** *Track length*

**approx. 180 km/h**  
*Average speed*

**32** *Gearshifts per lap*

**1m 32.244s**  
*Lap record qualifying*  
Mattias Ekström (Audi), 2008

**1m 32.532s**  
*Lap record race*  
Martin Tomczyk (BMW), 2014

## Audi's DTM track record at Hockenheim opener<sup>1</sup>

**18** Events  
35 overall including finale

**22** Races  
42 overall including finale

**4** Wins  
10 overall including finale

**4** 1-2 & 1-2-3 finishes  
9 overall including finale

**20** Podiums  
47 overall including finale

**7** Pole positions  
18 overall including finale

**3** Fastest race laps  
7 overall including finale

## Audi Zentrum close by

Audi Zentrum Heidelberg  
Hebelstraße 12  
D-69115 Heidelberg  
Phone +49 6221 535200



 Hockenheimring  
 Audi Zentrum (distance 21 km)



## 2 Lausitzring, May 30–31

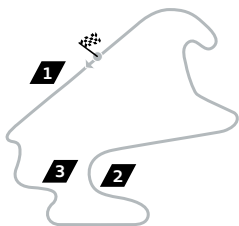

- 1** Top speed 239 km/h
- 2** Fastest corner 150 km/h
- 3** Slowest corner 75 km/h

### Audi's DTM track record at the Lausitzring

- 16** Events
- 15** Races
- 2** Wins
- 1** 1-2 & 1-2-3 finish
- 15** Podiums
- 2** Pole positions
- 6** Fastest race laps

**3.478 km** Track length

**approx. 160 km/h**  
Average speed

**24** Gearshifts per lap

**1m 17.463s**  
Lap record qualifying  
Gary Paffett (Mercedes-Benz), 2013

**1m 18.268s**  
Lap record race  
Mike Rockenfeller (Audi), 2013

### Audi Zentrum close by

Audi Zentrum Dresden  
Hamburger Straße 28  
D-01067 Dresden  
Phone +49 351 4920100



-  EuroSpeedway Lausitz
-  Audi Zentrum (distance 65 km)

## 3 Norisring, June 27–28

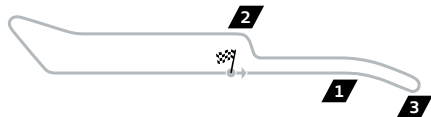

- 1** Top speed 245 km/h
- 2** Fastest corner 110 km/h
- 3** Slowest corner 51 km/h

**2.300 km** *Track length*

**approx. 175 km/h**  
*Average speed*

**22** *Gearshifts per lap*

**47.785s**  
*Lap record qualifying*  
Bruno Spengler (Mercedes-Benz), 2008

**48.446s**  
*Lap record race*  
Bruno Spengler (Mercedes-Benz), 2008

### Audi's DTM track record at the Norisring

- 17** Events
- 20** Races
- 3** Wins
- 1** 1-2 & 1-2-3 finish
- 15** Podiums
- 3** Pole positions
- 5** Fastest race laps

### Audi Zentrum close by

Audi Zentrum Nuremberg-  
Marienberg GmbH  
Marienbergstraße 88  
D-90411 Nuremberg  
Phone +49 911 54030



-  Norisring
-  Audi Zentrum (distance 9 km)

## 4 **Zandvoort, July 11–12**

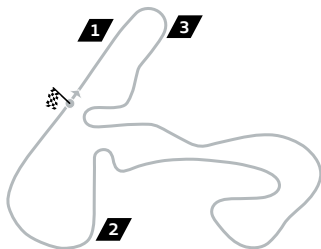

- 1** Top speed 246 km/h
- 2** Fastest corner 180 km/h
- 3** Slowest corner 83 km/h

**4.307 km** Track length

**approx. 170 km/h**  
Average speed

**25** Gearshifts per lap

**1m 30.449s**  
Lap record qualifying  
Pascal Wehrlein (Mercedes-Benz), 2014

**1m 32.296s**  
Lap record race  
Marco Wittmann (BMW), 2013

### **Audi's DTM track record at Zandvoort**

**14** Events

**14** Races

**8** Wins

**4** 1-2 & 1-2-3 finishes

**25** Podiums

**8** Pole positions

**6** Fastest race laps

### **Audi Zentrum close by**

Audi Centrum Amsterdam  
Klokenbergweg 19  
1101 AK Amsterdam Zuidoost  
The Netherlands  
Phone +31 20 5646464



-  Circuit Park Zandvoort
-  Audi Zentrum (distance 37 km)

## 5 Spielberg, August 01–02

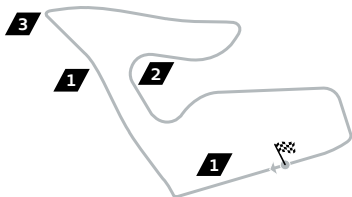

- 1** Top speed 230 km/h
- 2** Fastest corner 160 km/h
- 3** Slowest corner 60 km/h

### Audi's DTM track record in Spielberg

- 7 Events
- 7 Races
- 2 Wins
- 0 1-2 & 1-2-3 finishes
- 4 Podiums
- 3 Pole positions
- 2 Fastest race laps

**4.326 km** *Track length*

**approx. 185 km/h**  
*Average speed*

**31** *Gearshifts per lap*



**1m 24.588s**  
*Lap record qualifying*  
Bruno Spengler (BMW), 2013

**1m 25.266s**  
*Lap record race*  
Mike Rockenfeller (Audi), 2014

### Audi Zentrum close by

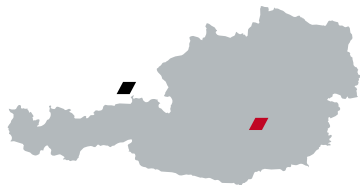
Audi Zentrum Rosenheim Ludwig  
Kriechbaum GmbH  
Innstraße 63  
D-83022 Rosenheim  
Phone +49 8031 389370



-  Red Bull Ring Spielberg
-  Audi Zentrum (distance 334 km)

## 6 Moscow, August 29–30

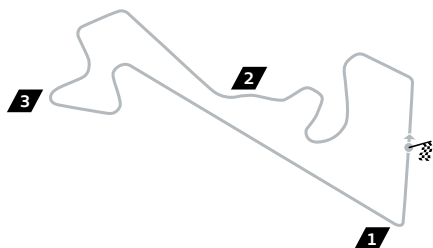

- 1** Top speed 245 km/h
- 2** Fastest corner 175 km/h
- 3** Slowest corner 75 km/h

**3.931 km** *Track length*

**approx. 160 km/h**  
*Average speed*

**28** *Gearshifts per lap*

**1m 28.523s**  
*Lap record qualifying*  
Maxime Martin (BMW), 2014

**1m 28.305s**  
*Lap record race*  
Miguel Molina (Audi), 2014



### *Audi's DTM track record in Moscow*

- 2** Events
- 2** Races
- 1** Win
- 1** 1-2 & 1-2-3 finish
- 3** Podiums
- 1** Pole position
- 2** Fastest race laps

### *Audi Zentrum close by*

*Audi Centr Moskva*  
Horoshevskoe Shosse, 70, Korpus 1  
123007 Moskva  
Russia  
Phone +7 495 7979090



-  *Moscow Raceway*
-  *Audi Zentrum (distance 98 km)*

## 7 Oschersleben, September 12–13

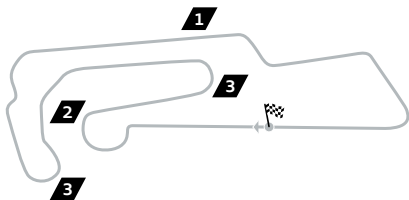

- 1** Top speed 223 km/h
- 2** Fastest corner 170 km/h
- 3** Slowest corner 100 km/h

### Audi's DTM track record at Oschersleben

- 14** Events
- 16** Races
- 6** Wins
- 4** 1-2 & 1-2-3 finishes
- 18** Podiums
- 6** Pole positions
- 8** Fastest race laps

**3.696 km** *Track length*

**approx. 165 km/h**  
*Average speed*

**21** *Gearshifts per lap*



**1m 20.011s**  
*Lap record qualifying*  
Adrien Tambay (Audi), 2014

**1m 21.255s**  
*Lap record race*  
Joey Hand (BMW), 2013

### Audi Zentrum close by

Audi Zentrum Magdeburg – Feser  
August-Bebel-Damm 6  
D-39126 Magdeburg  
Phone +49 391 2888677



-  Motorsport Arena Oschersleben
-  Audi Zentrum (distance 46 km)

## 8 Nürburgring, September 26–27

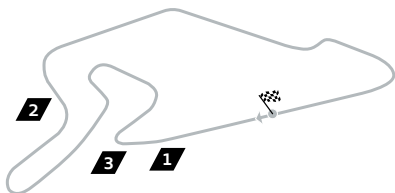

- 1** Top speed 240 km/h
- 2** Fastest corner 127 km/h
- 3** Slowest corner 74 km/h

### Audi's DTM track record at the Nürburgring

- 25** Events
- 34** Races
- 9** Wins
- 3** 1-2 & 1-2-3 finishes
- 23** Podiums
- 8** Pole positions
- 4** Fastest race laps

**3.629 km** Track length

**approx. 160 km/h**  
Average speed

**22** Gearshifts per lap

**1m 22.504s**  
Lap record qualifying  
Marco Wittmann (BMW), 2014

**1m 23.175s**  
Lap record race  
Marco Wittmann (BMW), 2014

### Audi Zentrum close by

Audi Zentrum Koblenz GmbH  
Friedrich-Mohr-Straße 4  
D-56070 Koblenz  
Phone +49 261 808040



-  Nürburgring
-  Audi Zentrum (distance 56 km)

## 9 Hockenheim, October 17.–18

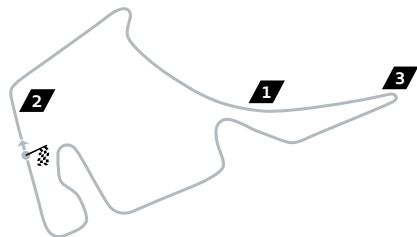

- 1** Top speed 258 km/h
- 2** Fastest corner 180 km/h
- 3** Slowest corner 65 km/h

**4.574 km** Track length

**approx. 180 km/h**  
Average speed

**32** Gearshifts per lap

**1m 32.244s**  
Lap record qualifying  
Mattias Ekström (Audi), 2008

**1m 32.532s**  
Lap record race  
Martin Tomczyk (BMW), 2014

### Audi's DTM track record at the Hockenheim finale<sup>1</sup>

**17** Events  
35 overall including opener

**20** Races  
42 overall including opener

**6** Wins  
10 overall including opener

**5** 1-2 & 1-2-3 finishes  
9 overall including opener

**27** Podiums  
47 overall including opener

**11** Pole positions  
18 overall including opener

**4** Fastest race laps  
7 overall including opener

### Audi Zentrum close by

Audi Zentrum Heidelberg  
Hebelstraße 12  
D-69115 Heidelberg  
Phone +49 6221 535200



 Hockenheimring  
 Audi Zentrum (distance 21 km)



## Titles and victories in the DTM



## Best Audi drivers each season

1<sup>st</sup> place

1990

*Hans-Joachim Stuck*

1991

*Frank Biela*

2002

*Laurent Aiello*

2004

*Mattias Ekström*

2007

*Mattias Ekström*

2008

*Timo Scheider*

2009

*Timo Scheider*

2<sup>nd</sup> place

2005

*Mattias Ekström*

2011

*Martin Tomczyk*

2014

*Mattias Ekström*

2013

*Mike Rockenfeller*

3<sup>rd</sup> place

2006

*Tom Kristensen*

2003

*Mattias Ekström* 4<sup>th</sup> place

2012

*Mike Rockenfeller* 4<sup>th</sup> place

1992

*Frank Biela* 15<sup>th</sup> place

2010

*Timo Scheider* 4<sup>th</sup> place

2001

*Laurent Aiello* 5<sup>th</sup> place

2000

*Laurent Aiello* 16<sup>th</sup> place

# Winning ratio by car

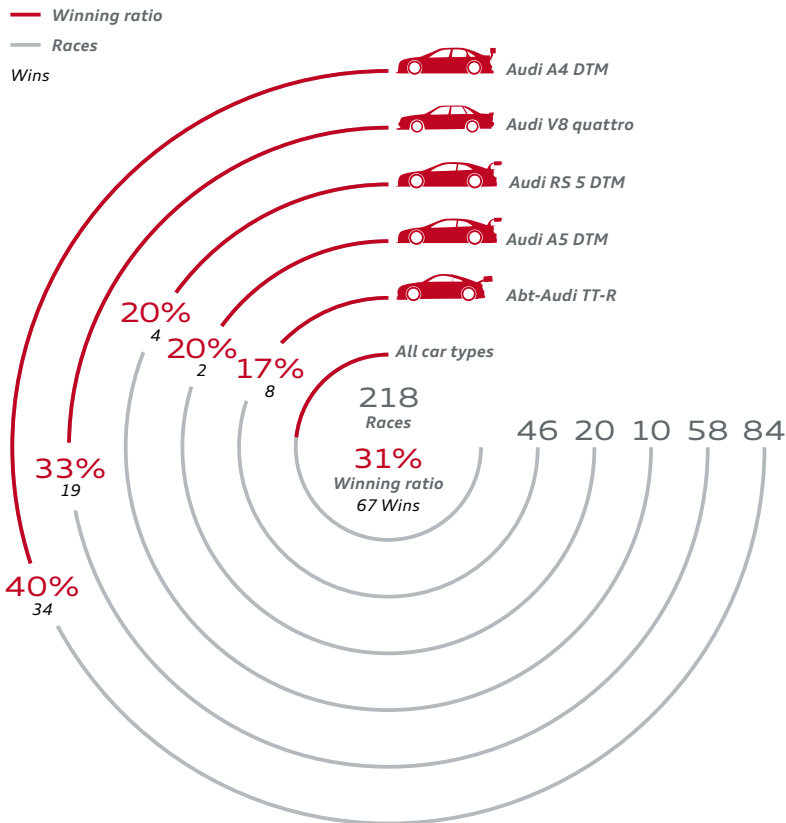

# Partners of Audi Sport in the DTM



*akrapovic.com*



*aral.de*

**Audi**  
Financial Services

*audi.com*

**Audi**  
Top Service®

*audi.com*



*autobild.de/auto-test*



*castrol.com*



*cisco.com*



*hoffmann-group.com*



*oris.ch/en*



*playboy.com*



*redbull.com*



*schaeffler.com*



*teufel.de*

## Other partners



*alpinestars.com*



*eibach.de*



*gerolsteiner.com*



*hofmuehl.de*



*man.eu*



*oz-racing.de*



*welt.de*



**GT racing**







# Contents

---

Audi R8 LMS – 2016 model .....	118
A glance in the R8 LMS cockpit .....	120
The Audi R8 LMS in action worldwide .....	122
Key personnel in the GT racing program .....	124
Endurance test for the new R8 LMS .....	125
Audi R8 LMS Cup .....	126
Audi race experience .....	127
Championship titles (drivers) in GT racing .....	128
Overall victories in endurance races .....	130
Partners of Audi Sport customer racing in GT racing .....	131

## Audi R8 LMS – 2016 model

### Technical progress

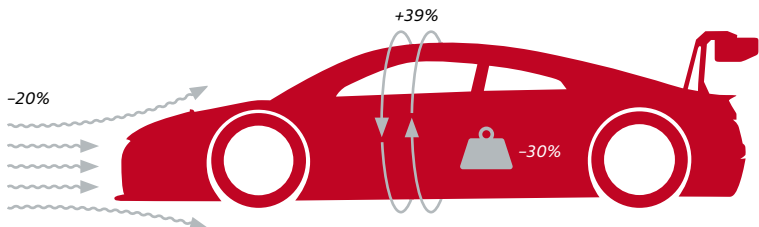

- / Aerodynamic drag reduced by 20 per cent
- / Torsional stiffness of chassis increased by 39 per cent
- / Chassis 30 kg lighter

### Robust V10 engine



- / After 10,000 km running: first service
- / After 20,000 km running: first rebuild

## Successful model Audi R8 LMS

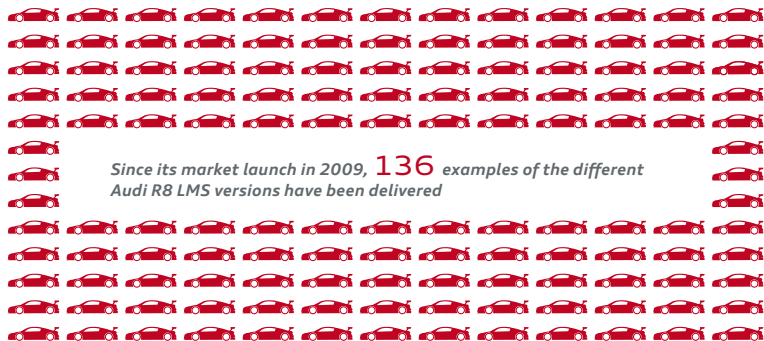

## Spare parts warehouse Audi Sport customer racing



**4,943**  
(incl. successor R8 6,490)  
*Individual parts*

### Parts deliveries 2014

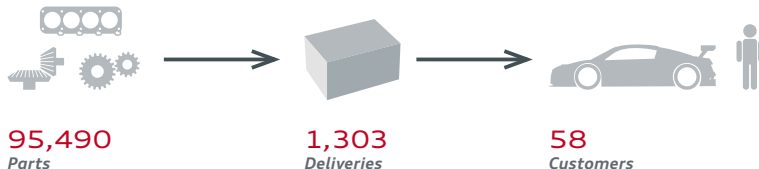

## A glance in the R8 LMS cockpit

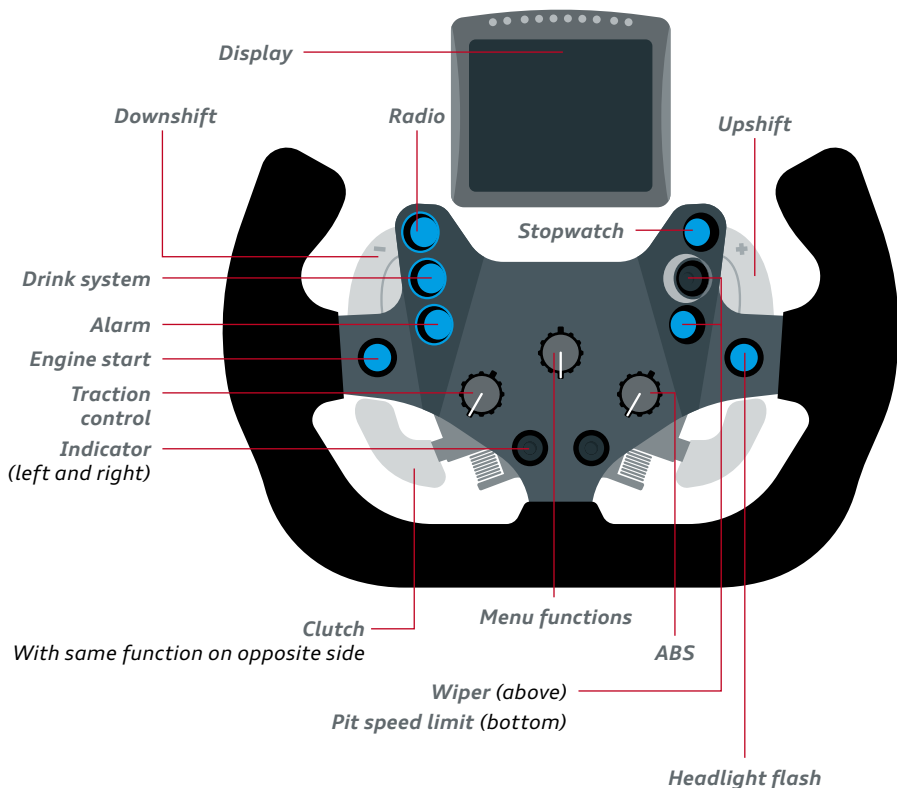

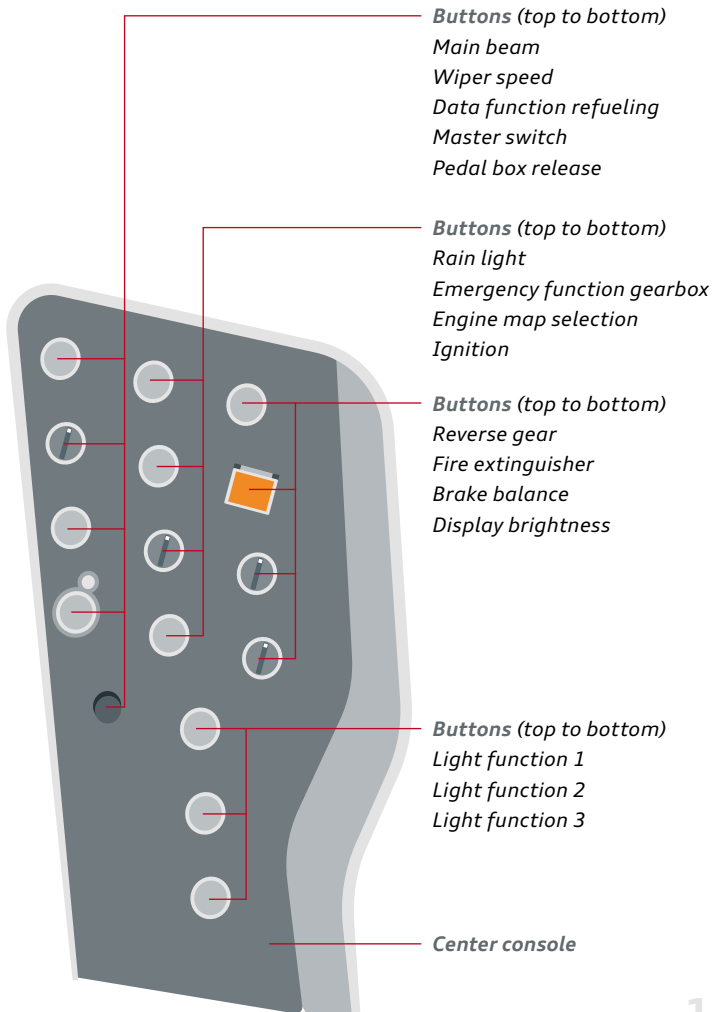

**Buttons (top to bottom)**

- Main beam
- Wiper speed
- Data function refueling
- Master switch
- Pedal box release

**Buttons (top to bottom)**

- Rain light
- Emergency function gearbox
- Engine map selection
- Ignition

**Buttons (top to bottom)**

- Reverse gear
- Fire extinguisher
- Brake balance
- Display brightness

**Buttons (top to bottom)**

- Light function 1
- Light function 2
- Light function 3

**Center console**

# The Audi R8 LMS in action worldwide

## Endurance races

**12h Abu Dhabi**  
[gulf12hours.com](http://gulf12hours.com)

**12h Bathurst**  
[bathurst12hour.com.au](http://bathurst12hour.com.au)

**12h Sepang**  
[sepang12hour.com](http://sepang12hour.com)

**24h Nürburgring**  
[24h-rennen.de](http://24h-rennen.de)

**24h Spa-Francorchamps**  
[total24hours.com](http://total24hours.com)

## America

**Pirelli World Challenge**  
[world-challenge.com](http://world-challenge.com)

**TUDOR United Sportsscar Championship**  
[imsa.com](http://imsa.com)

## Asia

**Audi R8 LMS Cup**  
[audir8lmscup.com](http://audir8lmscup.com)

**GT Asia**  
[afos.com](http://afos.com)

**Super GT**  
[supergt.net/en](http://supergt.net/en)

**Taiwan**  
[pic-taiwan.com](http://pic-taiwan.com)

**Thailand Super Series**  
[thailandsuperseries.net](http://thailandsuperseries.net)

## Australia

### **Australia**

[australiangt.com.au](http://australiangt.com.au)

## Europe

### **ADAC GT Masters**

[adac-gt-masters.de](http://adac-gt-masters.de)

### **DMV Gran Turismo Touring Car Cup**

[dmv-gtc.de](http://dmv-gtc.de)

### **GT Cup**

[gtcup.co.uk](http://gtcup.co.uk)

### **Spezial Tourenwagen Trophy**

[spezial-tourenwagen-trophy.de](http://spezial-tourenwagen-trophy.de)

### **VLN**

[vln.de](http://vln.de)

### **British Endurance Championship**

[britcar24hr.co.uk](http://britcar24hr.co.uk)

### **France**

[gt-tour.fr](http://gt-tour.fr)

### **Italy**

[acisportitalia.it/GT](http://acisportitalia.it/GT)

### **V de V Challenge GT**

[vdev.fr](http://vdev.fr)

## International

### **Blancpain Sprint Series**

### **Blancpain Endurance Series**

[blancpain-gt-series.com](http://blancpain-gt-series.com)

### **GT Open**

[gtopen.net](http://gtopen.net)

## Key personnel in the GT racing program

### Audi Sport customer racing



**Peter Mineif**  
Technical Project Manager



**Romolo Liebchen**  
Head of  
Audi Sport customer racing



**Dirk Spohr**  
Head of  
Customer Management



**Hendrik Többe**  
Sales/Marketing

### Audi race experience



**Klaus Demel**  
Head of  
Audi driving experience



**Rainer Kammerbauer**  
Project Manager of  
Audi race experience



**Josef Haider**  
Sporting Director  
Audi race experience

### Audi Sport customer racing Asia



**Rene Koneberg**  
Head of Audi Sport customer racing Asia

### Audi Sport customer racing North America



**Tristan Herbert**  
Manager Motorsport & Customer Racing  
Audi Sport customer racing North America



**Erin Keating**  
Senior Manager Events  
Audi of America



# Endurance test for the new R8 LMS

24h Nürburgring (D), May 16–17 

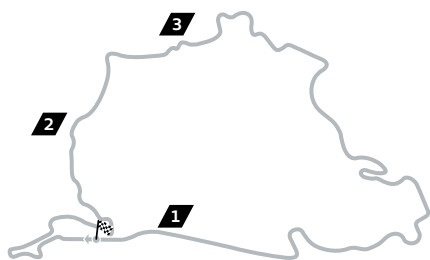

**25.378 km**  
*Track length*

**approx. 185 km/h**  
*Average speed*

**4,035.102 km**  
*Distance record*  
*Audi R8 LMS ultra, 2014*

- 1** Top speed 280 km/h
- 2** Fastest corner 240 km/h
- 3** Slowest corner 85 km/h

**2**  
*Audi victories*  
*2012, 2014*

24h Spa-Francorchamps (B), June 25–26 

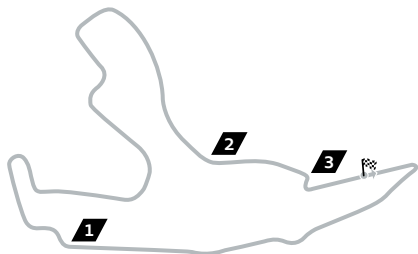

**7.004 km**  
*Track length*

**approx. 180 km/h**  
*Average speed*

**4,498.436 km<sup>1</sup>**  
*Distance record*  
*Ford Capri RS 2600, 1972*

- 1** Top speed 255 km/h<sup>2</sup>
- 2** Fastest corner 225 km/h<sup>2</sup>
- 3** Slowest corner 50 km/h<sup>2</sup>

**3**  
*Audi victories*  
*2011, 2012, 2014*

<sup>1</sup> Different track layout

<sup>2</sup> Values for the old R8 LMS. No data is currently available for the new R8 LMS

# Audi R8 LMS Cup

## Event calendar

- 1** 21-22/03 Zhuhai (China)
- 2** 16-17/05 Yeongam (South Korea)
- 3** June/July Taiwan
- 4** 08-09/08 Malaysia
- 5** 10-11/10 Fuji (Japan)
- 6** 31/10-01/11 Shanghai (China)

**2012**

*Debut season*

**22**

*Maximum number of competitors  
Identical Audi R8 LMS*

**37**

*kW increase with Push-to-pass*

## Race format

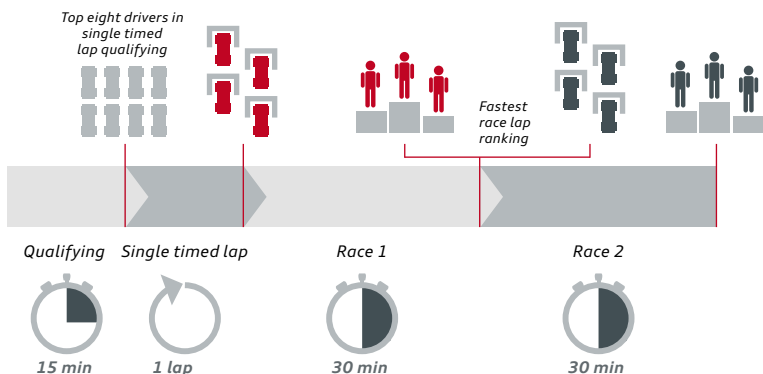

## Titles



Overall



Amateur Cup





Team





Four Rings Trophy

# Audi race experience



## **Experience Audi R8 LMS**

- ! *Race track experience recommended*
-  *Audi R8 LMS ultra, Audi R8 V10*
-  *Supervised and free driving*
-  *Driving Center Groß Dölln*



## **Experience Audi R8 LMS pro**

- ! *Race track experience*
-  *Audi R8 LMS ultra, Audi R8 V10*
-  *Supervised and free driving*
-  *Driving Center Groß Dölln*



## **Individual training motorsport**

- ! *Race track experience useful*
-  *Audi R8 LMS ultra, Audi R8 V10, Audi TT cup*
-  *Individual set-up*
-  *Driving Center Groß Dölln*

## **Experience Audi R8 LMS customer racing**

- ! *Motorsport license, motorsport experience, track knowledge Nürburgring Nordschleife*
-  *Audi R8 LMS ultra*
-  *Preparation for professional motorsport*
-  *Nürburgring*

- ! *Requirements*
-  *Training contents*

-  *Training car*
-  *Training location*

## Championship titles (drivers) in GT racing



**ADAC GT Masters**

*Christian Abt (D)*

**Belgium**

*Jean-François Hemroulle/*

*Tim Verbergt (B/B)*

**FIA GT3 (Europe)**

*Christopher Haase/*

*Christopher Mies (D/D)*



**Australia**

*Mark Eddy (AUS)*

**Blancpain Endurance Series**

*Greg Franchi (B)*

**Italy**

*Marco Bonanomi (I)*

**Super Taikyu Series**

*Tomonobu Fujii/Akihiro Tsuzuki/*

*Michael Kim (J/J)/USA)*

**Taça Portugal**

*César Campaniço/João Figueiredo (P/P)*

**Spain**

*César Campaniço/João Figueiredo (P/P)*



**DMSB-GT-Meisterschaft**

*Luca Ludwig (D)*

**Belgium**

*Greg Franchi/Anthony Kumpen (B/B)*

**Portugal**

*César Campaniço/*

*João Figueiredo (P/P)*

**Spain**

*César Campaniço/*

*João Figueiredo (P/P)*



**2012**

**Blancpain Endurance Series**

*Christopher Haase/Christopher Mies/  
Stéphane Ortelli (D/D/MC)*

**Portugal**

*César Campaniço/Carlos Vieira (P/P)*

**Taça Portugal**

*César Campaniço/Carlos Vieira (P/P)*

**Iberian Supercars Trophy**

*César Campaniço/Carlos Vieira (P/P)*

**Spain**

*Mikko Eskelinen (FIN)*



**2014**

**ADAC GT Masters**

*Kelvin van der Linde/  
René Rast (ZA/D)*

**Blancpain Endurance Series**

*Laurens Vanthoor (B)*

**Blancpain GT Series**

*Laurens Vanthoor (B)*



**2013**

**Belgium**

*Anthony Kumpen/Bert Longin/  
Maarten Makelberge (B/B/B)*

**FIA GT Series**

*Stéphane Ortelli/  
Laurens Vanthoor (MC/B)*

**GT Sprint International**

*Thomas Schöffler (D)*

**Portugal**

*César Campaniço (P)*

**Sweden**

*Jan Brunstedt (S)*

## Overall victories in endurance races

**2010****12h Hungary**

Thomas Gruber/Philip König/  
Walter Lechner/  
Niki Mayr-Melnhof (A/A/A/A)

**2012****12h Bathurst**

Christer Jöns/Christopher Mies/  
Darryl O'Young (D/D/HK)

**24h Nürburgring**

Marc Basseng/Christopher Haase/  
Frank Stippler/  
Markus Winkelhock (D/D/D/D)

**24h Spa**

Andrea Piccini/René Rast/  
Frank Stippler (I/D/D)

**24h Zolder**

Marco Bonanomi/Anthony Kumpen/  
Edward Sandström/  
Laurens Vanthoor (I/B/S/B)

**2011****12h Bathurst**

Marc Basseng/Christopher Mies/  
Darryl O'Young (D/D/HK)

**24h Spa**

Mattias Ekström/Greg Franchi/  
Timo Scheider (S/B/D)

**24h Zolder**

Enzo Ide/Bert Longin/  
Xavier Maassen/  
François Verbist (B/B/B/B)

**2014****24h Nürburgring**

Christopher Haase/  
Christian Mamerow/  
René Rast/  
Markus Winkelhock (D/D/D/D)

**24h Spa**

René Rast/Laurens Vanthoor/  
Markus Winkelhock (D/B/D)

## Partners of Audi Sport customer racing in GT racing



[akrapovic.com](http://akrapovic.com)



[castrol.com](http://castrol.com)



[eibach.de](http://eibach.de)



[mayer-motorsport.com](http://mayer-motorsport.com)



[staebli.com](http://staebli.com)





**Audi Sport  
TT Cup**





# Contents

---

Audi Sport TT Cup – development in record time.....	136
Endurance testing at Motorland Aragón.....	137
Push-to-pass – more power at the push of a button ..	138
Overtaking with Push-to-pass.....	139
A glance in the Cup race car cockpit.....	140
Key personnel in the Audi Sport TT Cup .....	142
Centralized preparation of Cup race cars .....	143
The Audi Sport TT Cup .....	144
Audi Sport TT Cup drivers .....	146
Partners in the Audi Sport TT Cup .....	150

# Audi Sport TT Cup – development in record time



**Week 19/2014**

*Project start Audi Sport TT Cup*

**Week 31/2014**

*Completion of chassis*

**Week 41/2014**

*Completion of first prototype and initial shakedown*

**Week 42/2014**

*Presentation at DTM finale at Hockenheim*

**Week 46/2014**

*Completion of first test car*

**Week 04/2015**

*Announcement of driver line-up*

**Week 06/2015**

*Endurance testing at Aragón*

**Week 08/2015**

*Start of production of 35 vehicles*

**Week 10/2015**

*Fitness camp and first driver test*

**Week 18/2015**

*Season opener with two races at Hockenheim*

# Endurance testing at Motorland Aragón

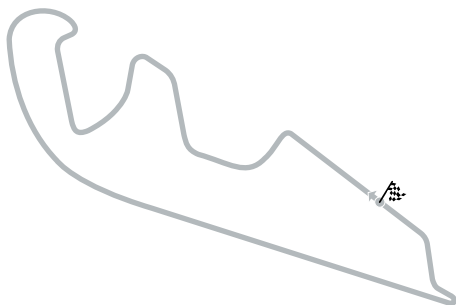

**4**  
Days

**32**  
Hours

**5,200 km**  
Kilometers

**2**  
Test drivers  
Miguel Molina,  
Marco Werner

## Technology transfer

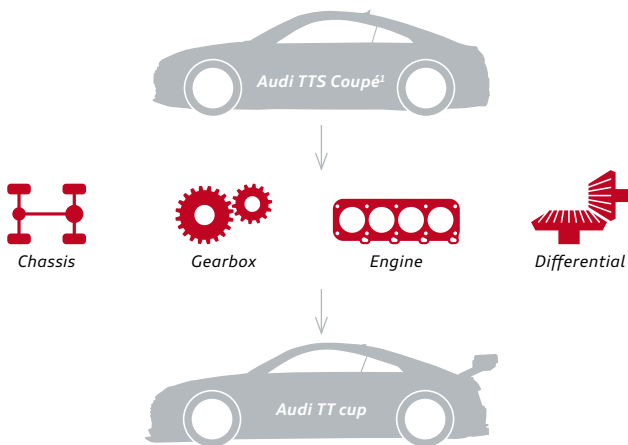

<sup>1</sup> Please refer to the list on page 151 for the consumption and emission values

## Push-to-pass – more power at the push of a button

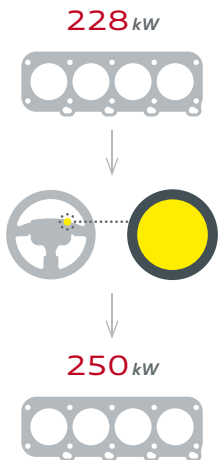

### *Engine power*

*After activating the Push-to-pass system, the power produced by the Cup race car momentarily increases by 22 kW. The duration and number of Push-to-pass activations are adjusted to suit the respective track*

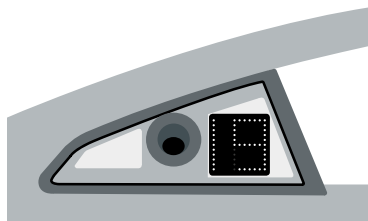

### *Number of Push-to-pass activations*

*Indicated by white LEDs in the rear side screens*

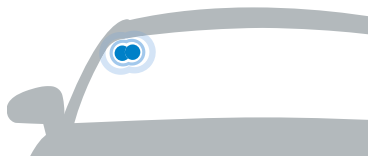

### *Push-to-pass in operation*

*Indicated by blue lights in the windscreen*

# Overtaking with Push-to-pass



## A glance in the Cup race car cockpit

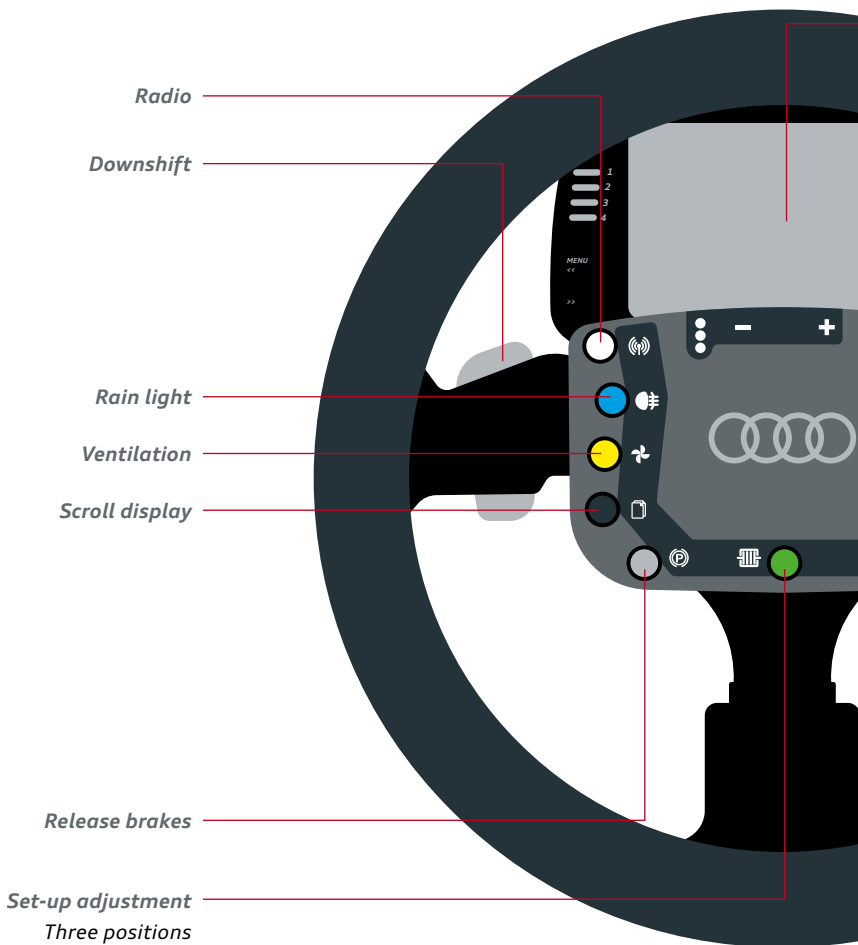



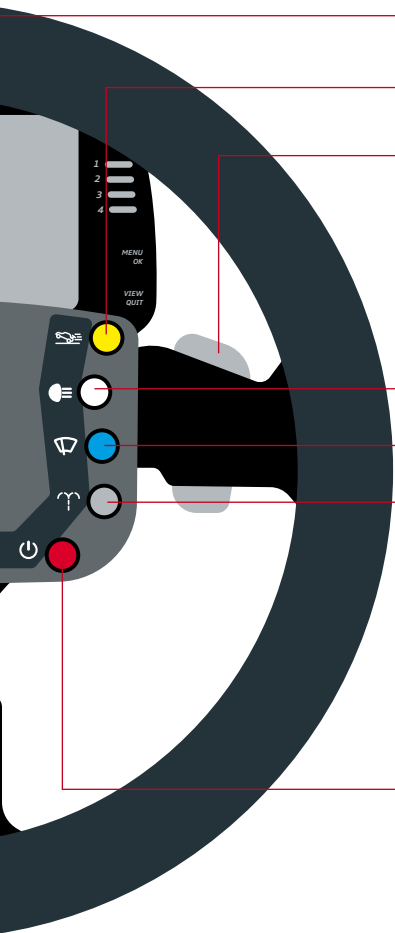

*Display*

*Push-to-pass*

*Upshift*

*Main beam*

*Wiper*

*Screen wash*

*Engine start*  
*If car not moving*

*Pit speed limit*  
*If car moving*

## Key personnel in Audi Sport TT Cup



**Rolf Michl**  
*Project Manager*



**Manuel Jahn**  
*Marketing/Partnerships*



**Christiane Fritz**  
*Marketing/Partnerships*



**Detlef Schmidt**  
*Technical Project Manager*

# Centralized preparation of Cup race cars

## *Permanent starters*



## *Guest starters*



## *Centralized preparation of cars By quattro GmbH*

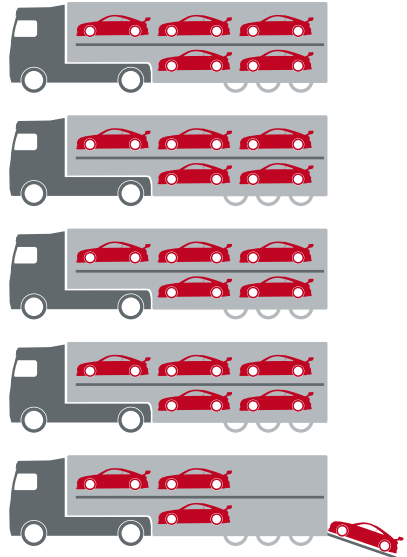

### **Individual setting options for the driver**

- / Position of steering wheel, pedal, seat and safety harness
- / Front and rear anti-roll bars
- / Tire pressure within the defined thresholds
- / Traction Control System (TCS)
- / Differential mapping in three modes

All other parameters on all cars are adjusted and set exclusively by representatives of the general contractor.

# The Audi Sport TT Cup

All events support the DTM

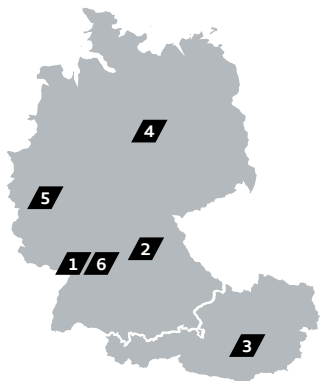

- 1** Hockenheim
- 2** Norisring
- 3** Spielberg
- 4** Oscherleben
- 5** Nürburgring
- 6** Hockenheim

## Race format

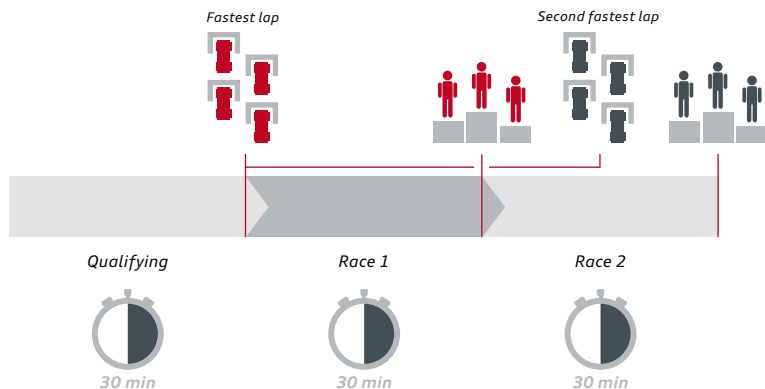

## Starter

18 permanent starters (age, sex, nationality)

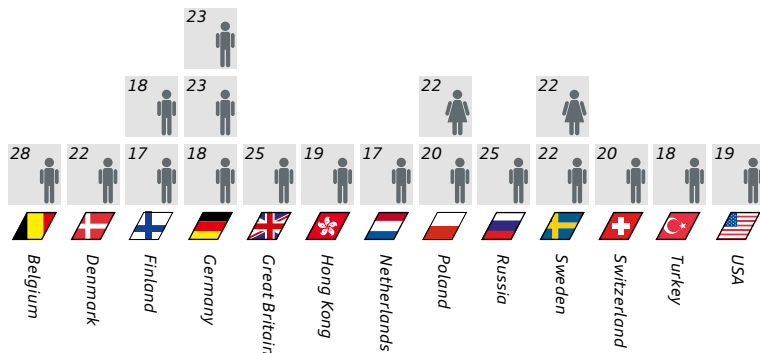

6 guest starters per event



Celebrities



Journalists



Motorsport legends

All guest starters must possess an international racing license, and before the event must have participated in one of the special qualification courses run by the Audi driving experience on behalf of quattro GmbH.

## Social Buzz Ranking



- / Driver activity on Facebook
- / Ranking on audi-motorsport.com
- / Winners get prizes

## Important links

**Audi Sport TT Cup**

#AudiSport

#TTCup

#challengerswelcome

 [audi-motorsport.com](http://audi-motorsport.com)

 [AudiSport](https://www.facebook.com/AudiSport)

 [@Audi\\_\\_Sport](https://twitter.com/Audi__Sport)

# Audi Sport TT Cup drivers

## Entry list

- #3 Gosia Rdest (PL) 
- #5 Nikita Misyulya (RUS) 
- #7 Christoph Hofbauer (D) 
- #8 Shaun Thong (HK) 
- #9 Kaan Önder (TR) 
- #11 Levin Amweg (CH) 
- #14 Josh Caygill (GB) 
- #17 Nicolaj Møller Madsen (DK) 
- #26 Dominik Peitz (D) 
- #27 Dennis Marschall (D) 
- #33 Emil Lindholm (FIN) 
- #43 Jan Kisiel (PL) 
- #45 Joonas Lappalainen (FIN) 
- #49 Sebastian Landy (USA) 
- #50 Loris Hezemans (NL) 
- #55 Alexis van de Poele (B) 
- #89 Mikaela Åhlin-Kottulinsky (S) 
- #92 Anton Marklund (S) 

Gosia Rdest 



- \* January 14, 1993, Żyrardów (PL)
- 📍 Krakow (PL)
- 📖 Wants to be the first woman on the moon

 Gosia-Rdest-Life-is-a-Race

Nikita Misyulya 



- \* April 23, 1990, Kaunas (LT)
- 📍 Samara (RUS)
- 📖 Part of national Russian bike trials team for five years

 Nikita.Misyulya

Christoph Hofbauer 



- \* July 15, 1991, Kösching (D)
- 📍 Lippertshofen (D)
- 📖 Loves to eat pork knuckles

 christoph.racing

Shaun Thong 



- \* November 01, 1995, Hong Kong (HK)
- ▲ Hong Kong (HK)
- i Likes to spend his holidays on the Maldives and Tahiti

 Shaun-Thongs-fans-page

Kaan Önder 



- \* January 10, 1997, Istanbul (TR)
- ▲ Istanbul (TR)
- i Likes to meditate before the race starts

 kaanonder1

Levin Amweg 



- \* September 11, 1994, Bern (CH)
- ▲ Bremgarten (CH)
- i A career as investment banker would have been a good alternative

 levin.amweg

Josh Caygill 



- \* June 22, 1989, Huddersfield (GB)
- ▲ Huddersfield (GB)
- i Prefers to drive around the Thruxton circuit in Hampshire

 joshcaygillracing

Nicolaj Møller Madsen 



- \* March 10, 1993, Odense (DK)
- ▲ Sønderø (DK)
- i Bases his driving style on that of Allan Simonsen

 Mollerermadsenfan

Dominik Peitz 



- \* November 20, 1991, Gütersloh (D)
- ▲ Verl (D)
- i Favorite race tracks: Nordschleife, Sachsenring and Bilster Berg

 [DominikPeitzMotorsport](#)

Dennis Marschall 



- \* August 15, 1996, Karlsruhe (D)
- ▲ Eggenstein (D)
- i Only weighs 65 kg despite being 1.83 m tall

 [Dennis-Marschall-Offizielle-Fanpage](#)

Emil Lindholm 



- \* July 19, 1996, Espoo (FIN)
- ▲ Degerby (FIN)
- i Likes to listen to music by Queen

 [ELindholmRacing](#)

Jan Kisiel 



- \* July 14, 1994, Warsaw (PL)
- ▲ Warsaw (PL)
- i Is a trained helicopter pilot

 [KisielRacing](#)

Joonas Lappalainen 



- \* March 01, 1998, Vantaa (FIN)
- ▲ Vantaa (FIN)
- i Alternatively, would like to have been a soccer player

 [joonaslappalainenofficial](#)



Sebastian  
Landy 



- \* December 14, 1995, Fairfax (USA)
- ▲ Great Falls (USA)
- i Prefers to spend his holiday at home

 [sebastianlandyracing](#)

Loris  
Hezemans 



- \* May 26, 1997, Amsterdam (NL)
- ▲ Uccle (B)
- i Favorite musician is the deceased rapper Tupac Shakur

 [lorishezemansfanpage](#)

Alexis  
van de Poele 



- \* June 21, 1989, Incourt (B)
- ▲ Incourt (B)
- i Would like to visit Tanzania

 [alexis.vandepoele](#)

Mikaela Åhlin-  
Kottulinsky 



- \* November 13, 1992, Karlstad (S)
- ▲ Hammarö (S)
- i Golf player Annika Sörenstam is her role model

 [MikaelaAhlinKottulinskyFanpage](#)

Anton  
Marklund 



- \* December 09, 1992, Skelleftea (S)
- ▲ Boliden (S)
- i Likes to go hunting in his spare time

 [marklundanton](#)

## Audi Sport TT Cup partners

**Audi**  
Original Zubehör



*audi.de/zubehoer*

**Audi**  
Top Service®

*audi.com*



*autobild.de/sportscars*



*hankooktire.com*



*lgchem.com*



*rehau.com*

## Other partners

**Audi**  
Consulting



*audi-consulting.de*

**AMAG**  
AUSTRIA METALL

*amag.at*



*pagidracing.com*

# Consumption values

Information about fuel consumption and CO<sub>2</sub> emissions as well as efficiency classes and ranges subject to tires / tire sets used:

## *Audi A1*

*Fuel consumption combined:*

*7.3–3.4 l/100 km*

*CO<sub>2</sub> emissions combined: 168–89 g/km*

## *Audi A3*

*Fuel consumption combined:*

*8.3–1.5 l/100 km*

*CO<sub>2</sub> emissions combined: 194–35 g/km*

## *Audi RS 4 Avant*

*Fuel consumption combined:*

*10.7 l/100 km*

*CO<sub>2</sub> emissions combined: 249 g/km*

## *Audi A6*

*Fuel consumption combined:*

*9.6–4.2 l/100 km*

*CO<sub>2</sub> emissions combined: 224–109 g/km*

## *Audi Q3*

*Fuel consumption combined:*

*8.4–4.4 l/100 km*

*CO<sub>2</sub> emissions combined: 198–114 g/km*

## *Audi Q5*

*Fuel consumption combined:*

*8.5–4.9 l/100 km*

*CO<sub>2</sub> emissions combined: 199–129 g/km*

## *Audi RS 7 Sportback*

*Fuel consumption combined:*

*9.5 l/100 km*

*CO<sub>2</sub> emissions combined: 221 g/km*

## *Audi TTS Coupé*

*Fuel consumption combined:*

*7.3–6.8 l/100 km*

*CO<sub>2</sub> emissions combined: 169–157 g/km*

## *Audi RS 3 Sportback*

*Fuel consumption combined:*

*8.3–8.1 l/100 km*

*CO<sub>2</sub> emissions combined: 194–189 g/km*

## *Audi RS 5*

*Fuel consumption combined:*

*10.7–10.5 l/100 km*

*CO<sub>2</sub> emissions combined: 249–246 g/km*

## *Audi RS 6 Avant*

*Fuel consumption combined:*

*9.6 l/100 km*

*CO<sub>2</sub> emissions combined: 223 g/km*

## *Audi RS Q3*

*Fuel consumption combined:*

*8.4 l/100 km*

*CO<sub>2</sub> emissions combined: 198 g/km*

## *Audi Q7*

*Fuel consumption combined:*

*8.3–5.7 l/100 km*

*CO<sub>2</sub> emissions combined: 193–149 g/km*

## *Audi R8 Coupé*

*Fuel consumption combined:*

*14.9–12.4 l/100 km*

*CO<sub>2</sub> emissions combined: 346–289 g/km*



# Contacts

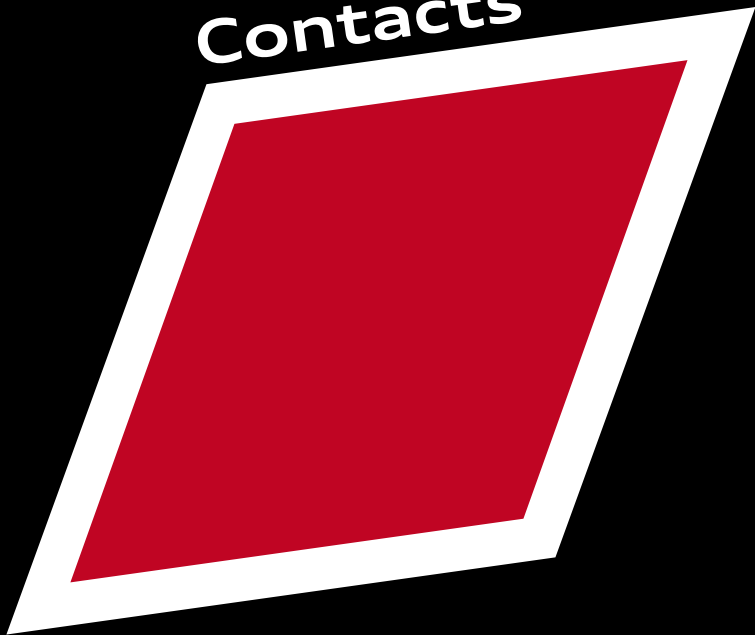

## Contacts



**Jürgen Pippig**

*Head of Communications Motorsport*

*Phone +49 841 89-35550*

*Mobile +49 160 90430634*

*E-mail juergen.pippig@audi.de*



**Virginia Brusch**

*Communications GT racing  
and Audi Sport TT Cup*

*Phone +49 841 89-41753*

*Mobile +49 151 52817968*

*E-mail virginia.brusch@audi.de*



**Daniel Schuster**

*Communications DTM*

*Phone +49 841 89-38009*

*Mobile +49 151 42134732*

*E-mail daniel2.schuster@audi.de*



**Petra Strack**

*Communications Motorsport*

*Phone +49 841 89-44784*

*Mobile +49 172 9101025*

*E-mail petra.strack@audi.de*



**Eva-Maria Veith**

*Communications LMP*

*Phone +49 841 89-33922*

*Mobile +49 173 9393522*

*E-mail eva-maria.veith@audi.de*

*Photos and information can be found at  
audi-motorsport.info and audi-mediaservices.com*

*Digital press kits for all four motorsport programs can be found  
digital.audi-presskit.de*



**AUDI AG**  
**Communications Motorsport**  
**D-85045 Ingolstadt**

**Phone +49 841 8934200**  
**E-mail [motorsport-media@audi.de](mailto:motorsport-media@audi.de)**

