

MediaInfo 2015

Audi Sport Factbook



 Audi Sport

Vorwort

LMP, DTM, GT-Sport und der neue Audi Sport TT Cup – Audi setzt 2015 noch konsequenter auf den Motorsport als bisher. Mit dem umfangreichsten Programm der Geschichte wird die Sportlichkeit der Marke weltweit betont.

Audi Sport steht seit 1981 für erfolgreichen Motorsport. Nun wird daraus eine Marke, unter der auch die sportlichen RS-Serienmodelle und der R8 vertrieben werden. Es ist ein starkes Zeichen, dass Audi Sport weltweit sowohl auf den Rennstrecken als auch im Straßenverkehr gleichermaßen präsent ist.

Einen umfassenden Überblick über das diesjährige Engagement von Audi Sport bietet Ihnen das neue Audi Sport Factbook. Hier werden buchstäblich Fakten geschaffen – informative und überraschende.

Finden Sie auf 152 Seiten 84 Themen, illustriert mit 227 Grafiken, erklärt mit 1.099 Zahlen, die Ihnen die Berichterstattung erleichtern sollen.



Jürgen Pippig

AUDI AG

Leiter Kommunikation Motorsport

Inhalt

Audi im Motorsport 2015 **6**

Audi-Motorsport-Programm 2015 ..	8
Terminkalender	10
Unsere Rennautos 2015.....	12

WEC **28**

Innovationen von Audi in Le Mans...	32
Audi R18 e-tron quattro: Motor	33
Audi R18 e-tron quattro: Hybridsystem.....	34
Prinzip der Rekuperation	36
Rekuperierte Hybridenergie.....	37
Blick in das Cockpit des R18	38
FIA-Langstrecken- Weltmeisterschaft (WEC)	40
Schlüsselfunktionen im LMP-Programm	42

DTM **72**

Audi RS 5 DTM: Sicherheitselemente	76
Drag Reduction System (DRS)	78
Blick in das Cockpit des RS 5 DTM..	80
Format der DTM-Wochenenden	82
Alle DTM-Jahre	84

Audi Sport **14**

Die Marke Audi Sport.....	16
Leitungsfunktionen im Motorsport-Programm von Audi ...	18
Audi Neuburg	20
Audi Sport – eine Erfolgsstory	22

Fahrer und Ingenieure	43
Audi Sport Team Joest	44
Die neun Fahrer im Porträt	45
Die acht Strecken im Überblick.....	54
Alle Sieger der 24h Le Mans	63
Alle 14 Streckenvarianten der 24h Le Mans	67
LMP-Titel und große LMP- Langstreckensiege von Audi.....	68
Alle Siege der LMP-Rennwagen von Audi 1999–2014	69
Partner von Audi Sport in der WEC...	70

Der DTM-Durchschnitts- Champion	85
Schlüsselfunktionen im DTM-Programm	86
Teams und Fahrer	88
Audi Sport Team Abt Sportsline	89

Audi Sport Team Phoenix.....	90	Titel und Erfolge in der DTM	109
Audi Sport Team Rosberg.....	91	Beste Audi-Fahrer je Saison	110
Die acht Fahrer im Porträt	92	Siegquote nach Fahrzeugtypen...	111
Die Strecken im Überblick	100	Partner von Audi Sport in der DTM..	112

GT-Sport **114**

Audi R8 LMS – Modelljahr 2016...	118	Audi race experience.....	127
Blick in das Cockpit des R8 LMS...	120	Meistertitel (Fahrer) im GT-Sport...	128
Einsatzgebiete Audi R8 LMS.....	122	Gesamtsiege bei Langstrecken-Rennen.....	130
Schlüsselfunktionen GT-Sport-Programm	124	Partner von Audi Sport customer racing im GT-Sport	131
Härtetest für den neuen R8 LMS ..	125		
Audi R8 LMS Cup	126		

Audi Sport TT Cup **132**

Audi Sport TT Cup – Entwicklung in Rekordzeit	136	Zentraler Einsatz der Cup-Rennwagen	143
Dauererprobung im Motorland Aragón.....	137	Der Audi Sport TT Cup.....	144
Push-to-Pass – mehr Power auf Knopfdruck	138	Fahrer Audi Sport TT Cup	146
Überholvorgang mit Push-to-Pass..	139	Partner im Audi Sport TT Cup.....	150
Blick in das Cockpit des Cup-Rennwagens	140	Verbrauchswerte.....	151
Schlüsselfunktionen im Audi Sport TT Cup	142		

Kontakte **152**

Audi im Motorsport 2015



Audi-Motorsport-Programm 2015

WEC

Audi R18 e-tron quattro



DTM

Audi RS 5 DTM



GT-Sport

Audi R8 LMS



Audi Sport TT Cup

Audi TT cup



Terminkalender

WEC

- | | | |
|----------|------------|--------------------------|
| 1 | 12.04. | 6h Silverstone (GB) |
| 2 | 02.05. | 6h Spa-Francorchamps (B) |
| 3 | 13.-14.06. | 24h Le Mans (F) |
| 4 | 30.08. | 6h Nürburgring (D) |
| 5 | 19.09. | 6h Austin (USA) |
| 6 | 11.10. | 6h Fuji (J) |
| 7 | 01.11. | 6h Shanghai (CN) |
| 8 | 21.11. | 6h Bahrain (BRN) |

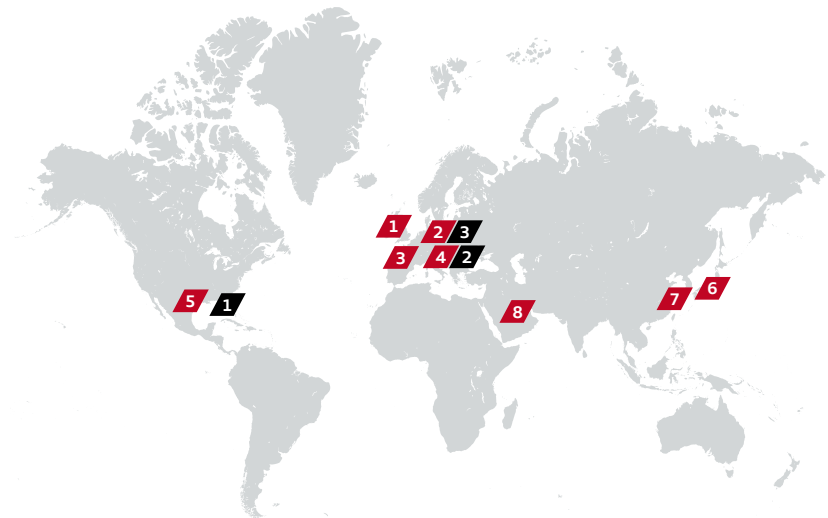

Wichtige 24-Stunden-Rennen

- | | | |
|----------|------------|---------------------------|
| 1 | 24.-25.01. | 24h Daytona (USA) |
| 2 | 16.-17.05. | 24h Nürburgring (D) |
| 3 | 25.-26.07. | 24h Spa-Francorchamps (B) |

DTM / Audi Sport TT Cup

- 1** 02.–03.05. Hockenheim (D)
- 2** 30.–31.05. Lausitzring (D)
- 3** 27.–28.06. Norisring (D)
- 4** 11.–12.07. Zandvoort (NL)
- 5** 01.–02.08. Spielberg (A)

- 6** 29.–30.08. Moskau (RUS)
- 7** 12.–13.09. Oschersleben (D)
- 8** 26.–27.09. Nürburgring (D)
- 9** 17.–18.10. Hockenheim (D)

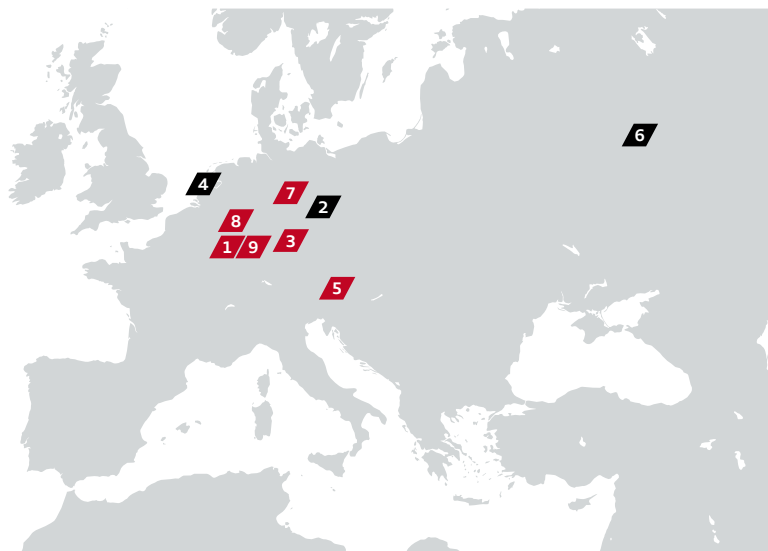

1 DTM und Audi Sport TT Cup bestreiten Rennen

2 Nur die DTM bestreitet Rennen

Unsere Rennautos 2015



Audi R18 e-tron quattro

Autotyp LMP1-Sportwagen
 Gewicht 870 kg
 Länge 4.650 mm
 Motortyp TDI
 Hubraum 4.000 cm³

Zylinder V6
 Leistung 1,4 kg/kW (mit Hybrid)
 Leistungsgewicht 0-100 km/h 2,6 Sek.
 Toppspeed 324 km/h



Audi RS 5 DTM

Autotyp DTM-Tourenwagen
 Gewicht 1.120 kg (inkl. Fahrer)
 Länge 5.010 mm
 Motortyp Saugmotor
 Hubraum 4.000 cm³

Zylinder V8
 Leistung 340 kW
 Leistungsgewicht 0-100 km/h 2,9 Sek.
 Toppspeed 280 km/h



Audi R8 LMS

Autotyp	GT3-Sportwagen	Zylinder	V10
Gewicht	1.225 kg	Leistung	430 kW
Länge	4.583 mm	Leistungsgewicht	2,8 kg/kW
Motortyp	Saugmotor	0-100 km/h	2,75 Sek.
Hubraum	5.200 cm ³	Topspeed	295 km/h



Audi TT cup

Autotyp	Cup-Tourenwagen	Zylinder	4 (Reihe)
Gewicht	1.125 kg	Leistung	228 kW/250 kW (mit Push-to-Pass)
Länge	4.260 mm	Leistungsgewicht	4,9 kg/kW
Motortyp	TFSI	0-100 km/h	4,5 Sek.
Hubraum	1.984 cm ³	Topspeed	239 km/h

Audi Sport



Die Marke Audi Sport

- / Seit 1981 steht Audi Sport für erfolgreichen Motorsport
- / Aus Audi Sport hat sich eine eigene Marke entwickelt, zu der inzwischen auch die sportlichsten Serienmodelle von Audi gehören
- / Ein Großteil der Aktivitäten ist im neuen Kompetenz-Center Motorsport in Neuburg gebündelt

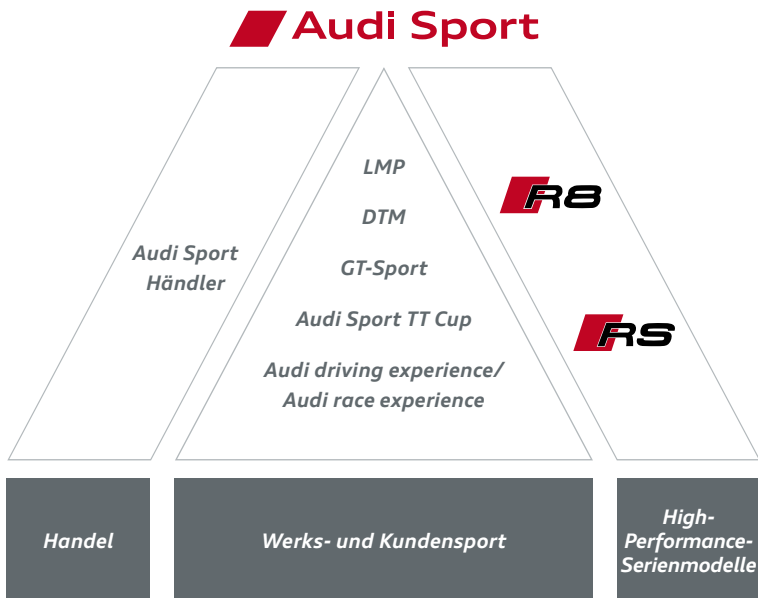

Aktuelle High-Performance-Serienmodelle



Audi RS 3 Sportback



Audi RS 4 Avant



Audi RS 5 Cabriolet



Audi RS 5 Coupé



Audi RS 6 Avant



Audi RS 7 Sportback



Audi RS Q3



Audi R8 Coupé

Leitungsfunktionen im Motorsport-Programm von Audi

Audi Sport



Chris Reinke
Leiter LMP

weiter auf
Seite 42



Dr. Wolfgang Ullrich
Leiter Audi Sport



Dieter Gass
Leiter DTM

weiter auf
Seite 86



Jörg Zander
Leiter Technik



Klaus Dieter Krieger
Leiter Finanz und
Organisation

Technik



Wolfgang-Dieter Appel
Leiter Fahrzeug-
entwicklung



Ulrich Baretzky
Leiter
Motoren-
entwicklung



Joachim Hausner
Leiter Gesamt-
fahrzeug



Norbert Medele
Leiter Werkstatt



Thomas Laudenbach
Leiter Elektrik,
Elektronik,
Hybrid

Finanz und Organisation



Siegfried Krause
Leiter Beschaffung
und Partnerschaften



Rainer Kammergruber
Leiter Audi Sport
Rennorganisation/Reglement

Kundensport

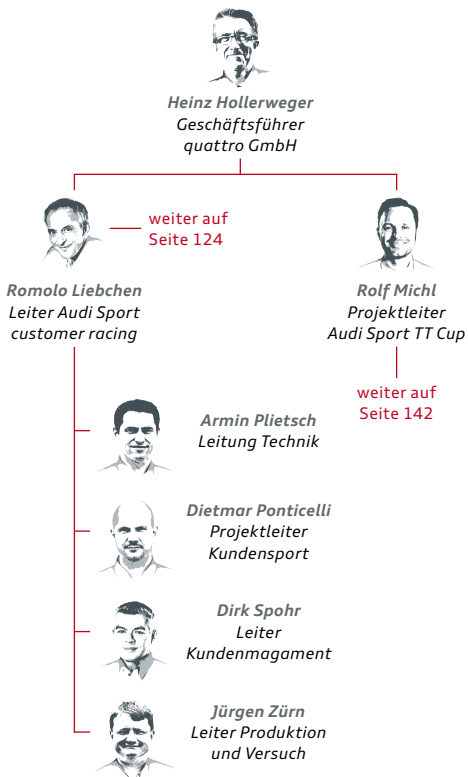

Audi Neuburg

- / Audi driving experience center
- / Kompetenz-Center Motorsport / Audi Sport
- / Audi Sport customer racing
- / Entwicklungsfunktionen der Technischen Entwicklung

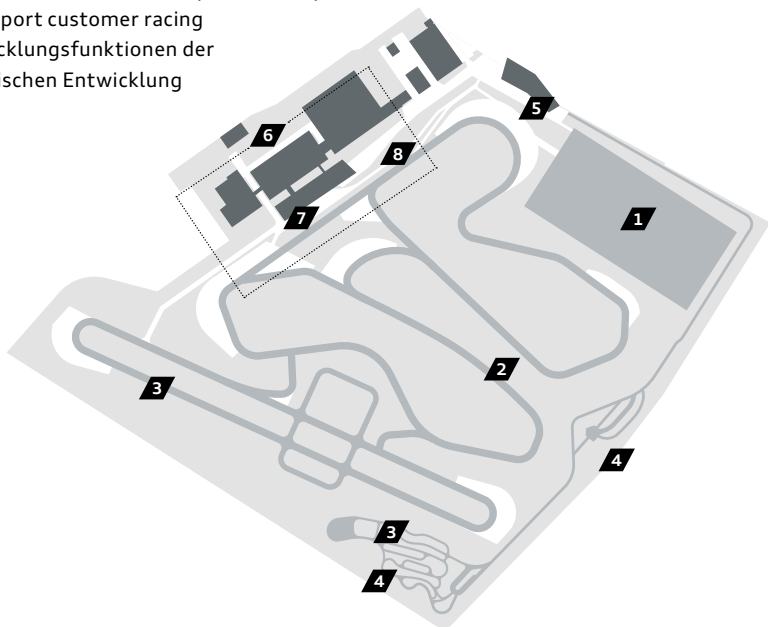

2010–2011

*Grundstückskauf und
Aufstellung Bebauungsplan*

August 2012

Spatenstich

2011–2012

Planungsphase

1 30.000 m²

Dynamikfläche

2 2,2 km

Handlingstrecke

3 1,2 km

Gerade

4 10

Offroad-Module

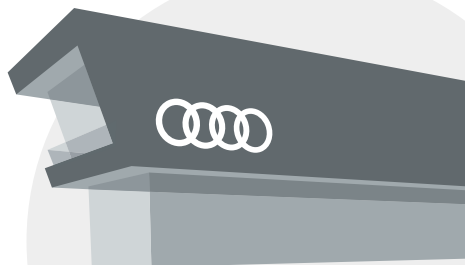

5 Audi driving experience center

6 Kompetenz-Center Motorsport

7 Audi Sport

8 Audi Sport customer racing

460 Mitarbeiter Kompetenz-Center Motorsport

(350 Audi-Mitarbeiter, 110 Mitarbeiter von Partnerfirmen)



Mai 2014

*Inbetriebnahme
Audi driving experience center*

Frühjahr 2015

*Inbetriebnahme
Audi Sport customer racing*

November 2013

Richtfest Motorsport-Gebäude

August 2014

*Eröffnung Audi Neuburg / Inbetriebnahme
Kompetenz-Center Motorsport / Audi Sport*

Audi Sport – eine Erfolgsstory

Leiter Audi Sport

Jürgen Stockmar (D), Walter Treser (D)

Reinhard Rode (D)

Roland Gumpert (D)

1980

1981

1982

Erprobung

Rallyesport



Audi quattro



Audi quattro



Audi quattro¹

¹ Rallye-Weltmeister
Hersteller

Herwart Kreiner (A)

1986

1987

1988

Rallyesport

Trans Am



Audi Sport quattro S1



Audi 200 quattro



Audi 200 quattro⁴



Audi Gruppe S²



Audi Coupé quattro

Pikes Peak



Audi Sport quattro S1²



Audi Sport quattro S1³

¹ Keine Renneinsätze
² Sieger Pikes Peak

³ Sieger Pikes Peak

⁴ Sieger Trans Am

1983

1984

1985

Rallyesport



Audi quattro A1 und A2¹



Audi quattro A2²



Audi Sport quattro



Audi 80 quattro



Audi Sport quattro²



Audi Sport quattro S1

Pikes Peak



Audi Sport quattro



Audi Sport quattro³

¹Rallye-Weltmeister

²Rallye-Weltmeister
Fahrer & Hersteller

³Sieger Pikes Peak

Dieter Basche (D)

1989

1990

1991

IMSA GTO

DTM



Audi 90 quattro



Audi V8 quattro¹



Audi V8 quattro²

¹Sieger DTM

²Sieger DTM

Dr. Wolfgang Ullrich (A)

1992

1993

1994

DTM



Audi V8 quattro



Audi 80 DTM Klasse 1¹

Supertourenwagen



Audi 80 quattro²



Audi 80 competition³

¹Keine Renneinsätze

²Französischer
Tourenwagen-Meister

³Italienischer
Tourenwagen-Meister

1998

1999

2000

Supertourenwagen



Audi A4

Sportwagen LMP



Audi R8R



Audi R8¹



Audi R8R

Sportwagen LMGT-P



Audi R8C

¹Sieger 24h Le Mans,
Sieger ALMS Fahrer & Hersteller

1995

1996

1997

Supertourenwagen



Audi A4 quattro¹



Audi A4 quattro²



Audi A4 quattro³



Audi A4

¹ *Italienischer
Tourenwagen-Meister,
Sieger Tourenwagen-Weltcup*

² *Supertourenwagen-Meister in
Australien, Belgien, Deutsch-
land, Großbritannien, Italien,
Spanien & Südafrika*

³ *Mitteleuropa-Tourenwagen-
Meister*

2001

2002

2003

Sportwagen LMP



Audi R8¹



Audi R8²



Audi R8³

¹ *Sieger 24h Le Mans,
Sieger ALMS Fahrer & Hersteller,
Sieger European Le Mans Series*

² *Sieger 24h Le Mans,
Sieger ALMS Fahrer &
Hersteller*

³ *Sieger ALMS Fahrer & Hersteller*

2004

2005

2006

Sportwagen LMP1



Audi R8¹



Audi R8³



Audi R8⁴

Sportwagen LMP1



Audi R10 TDI⁵

DTM



Audi A4 DTM²



Audi A4 DTM



Audi A4 DTM

¹ Sieger 24h Le Mans,
Sieger ALMS Fahrer & Hersteller,
Sieger Le Mans Endurance Series

³ Sieger 24h Le Mans,
Sieger ALMS Fahrer &
Hersteller

^{4,5} Sieger ALMS Fahrer & Hersteller
⁵ Sieger 24h Le Mans

² Sieger DTM Fahrer & Hersteller

2010

2011

2012

Sportwagen LMP1



Audi R15 TDI¹



Audi R18 TDI²



Audi R18 e-tron quattro⁴/ultra

DTM



Audi A4 DTM



Audi A4 DTM³



Audi A5 DTM

Kundensport



Audi R8 LMS



Audi R8 LMS



Audi R8 LMS/ultra/GRAND-AM



Audi TT RS

¹ Sieger 24h Le Mans

² Sieger 24h Le Mans
³ Sieger DTM

⁴ Sieger 24h Le Mans,
Sieger FIA WEC Fahrer &
Hersteller

2007

2008

2009

Sportwagen LMP1

*Audi R10 TDI¹**Audi R10 TDI³**Audi R15 TDI*

DTM

*Audi A4 DTM²**Audi A4 DTM⁴**Audi A4 DTM⁵*

Kundensport

*Audi R8 LMS*

¹ *Sieger 24h Le Mans,
Sieger ALMS Fahrer &
Hersteller*

² *Sieger DTM*

³ *Sieger 24h Le Mans, Sieger
ALMS Fahrer & Hersteller,
Sieger Le Mans Series*

⁴ *Sieger DTM*

⁵ *Sieger DTM*

2013

2014

2015

Sportwagen LMP1

*Audi R18 e-tron quattro¹**Audi R18 e-tron quattro³**Audi R18 e-tron quattro*

DTM

*Audi RS 5 DTM²**Audi RS 5 DTM⁴**Audi RS 5 DTM*

Kundensport

*Audi R8 LMS/ultra/GRAND-AM**Audi R8 LMS/ultra**Audi R8 LMS/ultra**Audi TT cup*

¹ *Sieger 24h Le Mans,
Sieger FIA WEC*

² *Sieger DTM*

³ *Sieger 24h Le Mans*

⁴ *Sieger DTM Hersteller*

WEC

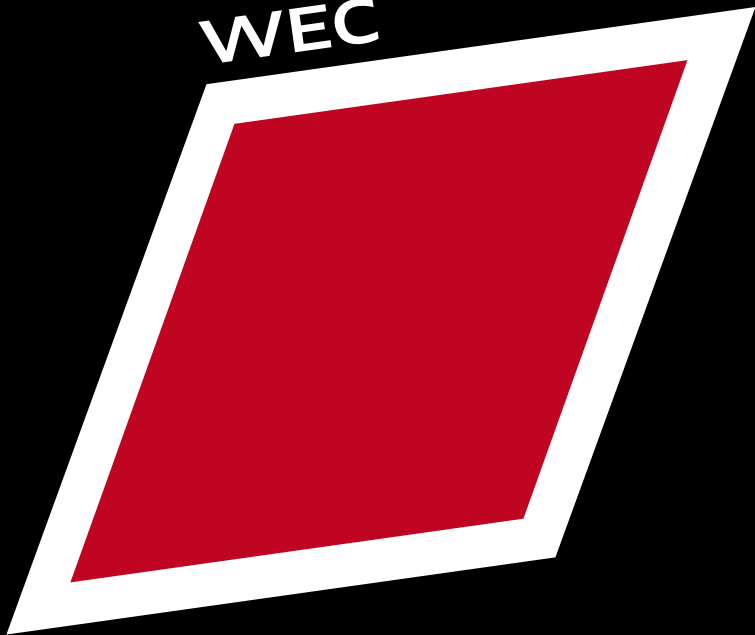

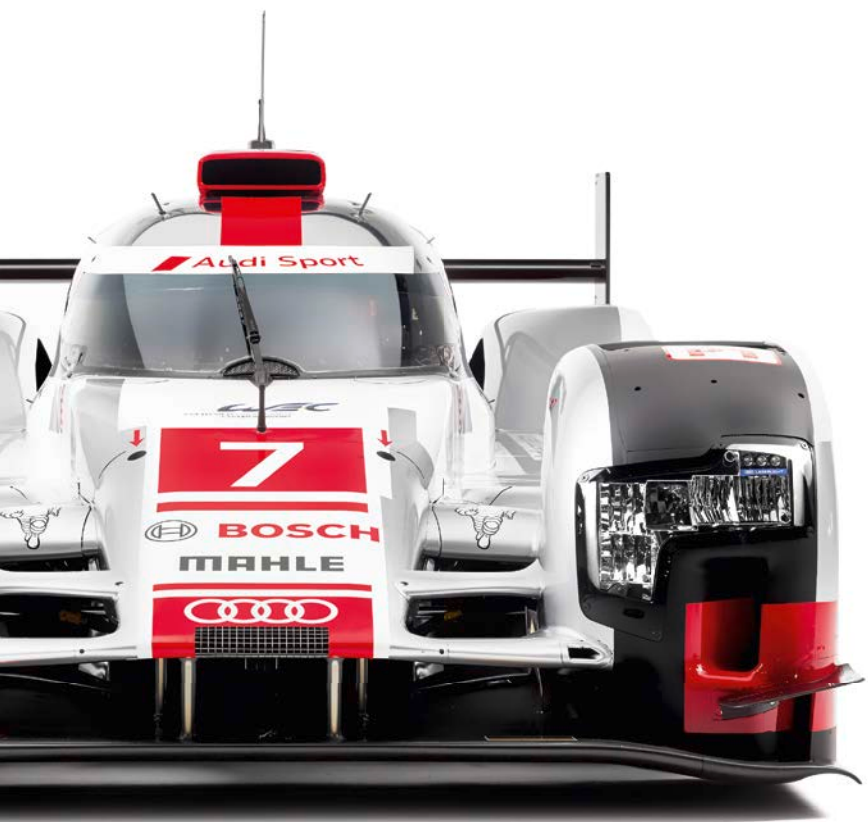

Inhalt

Innovationen von Audi in Le Mans	32
Audi R18 e-tron quattro: Motor	33
Audi R18 e-tron quattro: Hybridsystem	34
Prinzip der Rekuperation	36
Rekuperierte Hybridenergie	37
Blick in das Cockpit des R18	38
FIA-Langstrecken-Weltmeisterschaft (WEC)	40
Schlüsselfunktionen im LMP-Programm	42
Fahrer und Ingenieure	43
Audi Sport Team Joest	44
Die neun Fahrer im Porträt	45
Die acht Strecken im Überblick	54
Alle Sieger der 24h Le Mans	63
Alle 14 Streckenvarianten der 24h Le Mans	67
LMP-Titel und große LMP-Langstreckensiege von Audi ..	68
Alle Siege der LMP-Rennwagen von Audi 1999–2014 ...	69
Partner von Audi Sport in der WEC	70

Innovationen von Audi in Le Mans

2001

TFSI-Technologie

2006

TDI-Technologie / LED-Tagfahrlicht

2009

Lithium-Ionen-Batterie / Wechsel von V12 TDI auf V10 TDI / Turbolader mit VTG-Regelung

2010

LED-Lichttechnologie

2011

Downsizing von V10 TDI (5,5 Liter) auf V6 TDI (3,7 Liter) / Doppelflutig beaufschlagter Mono-Turbolader / Voll-LED-Scheinwerfer / Intensivierung ultra-Leichtbau

2012

Hybridantrieb e-tron quattro mit Hybridantrieb 150 kW / Matrix-LED-Scheinwerfer

2013

Leistungssteigerung des Hybridantriebs auf mehr als 160 kW

2014

Effizienz-Reglement (Verbrauchsverringierung im Vergleich zu 2006: minus 38 Prozent) / V6 TDI (4 Liter) / Audi Laserlicht / Optimierung Leichtbau: erster LMP-Rennwagen von Audi, der leichter als 900 kg ist (870 kg) / Leistungssteigerung Hybridantrieb auf mehr als 170 kW / Speicherkapazität 600 kJ / Verringerung von Fahrzeug- und Reifenbreite / deutliche aerodynamische Optimierung

2015

Überarbeitung V6 TDI zur nochmaligen Verbrauchsverringierung / Leistungssteigerung Hybridantrieb auf mehr als 200 kW, Speicherkapazität 700 kJ / weitere Optimierung des Leichtbaus / deutliche aerodynamische Optimierung

Audi R18 e-tron quattro: Motor

VTG-Turbolader

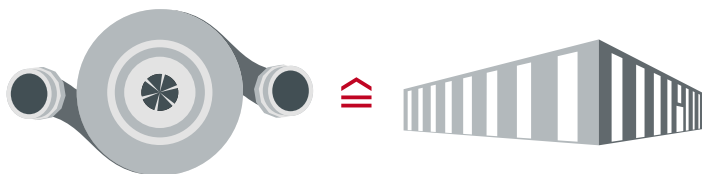

- / Fördert 2.000 kg Luft pro Stunde bei Volllast (4 bar)
- / Bei einer Luftdichte von 1,3 kg/m³ ergibt sich daraus ein Volumen von 1.538,46 m³
- / Das entspricht dem Inhalt einer leeren Fabrikhalle mit einem Innenmaß von 10 Meter Länge, 10 Meter Breite und 15,38 Meter Höhe

Einspritzdruck des V6 TDI

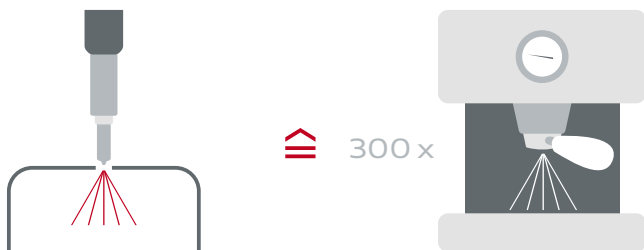

- / Das Dieselöl wird mit 3.000 bar Druck in die Brennräume des V6 TDI im R18 e-tron quattro eingespritzt
- / Zum Vergleich: Der Druck ist 300-mal größer als der Brühdruck einer Espressomaschine

Audi R18 e-tron quattro: Hybridsystem

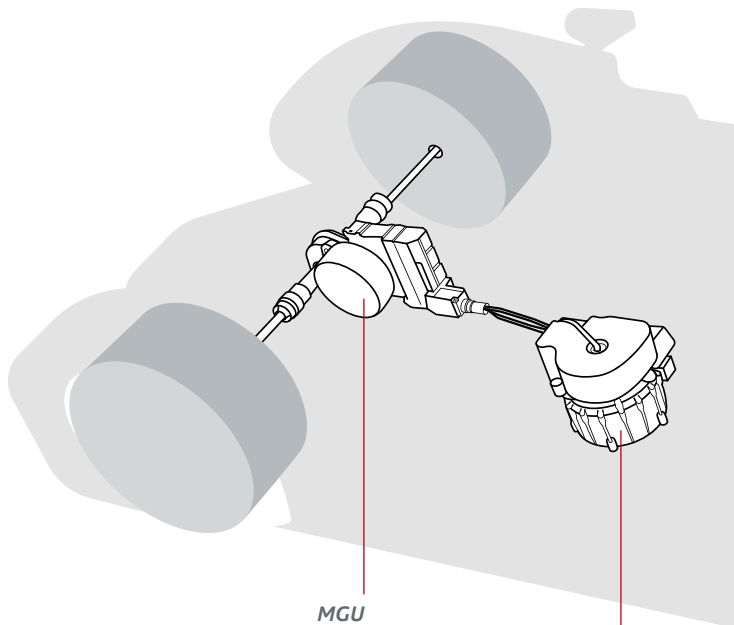

MGU

Die Motor-Generator-Unit (MGU) verwandelt die kinetische Energie beim Bremsen in Strom.

Umgekehrt kann sie mit der zurückgewonnenen Energie die Vorderachse antreiben.

Drehmassenspeicher

Der Drehmassenspeicher im Cockpit wird von der MGU gespeist. Er läuft mit mehr als 45.000 Umdrehungen pro Minute und hat einen nutzbaren Hub von 700 Kilojoule.

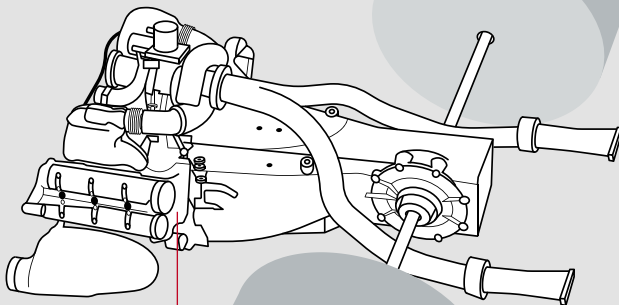

V6-TDI-Motor

Der leistungsstarke und effiziente V6 TDI mit 558 PS treibt die Hinterachse an. Er verbraucht 40 Prozent weniger Energie als der erste V12 TDI von Audi in Le Mans im Jahr 2006.

Prinzip der Rekuperation

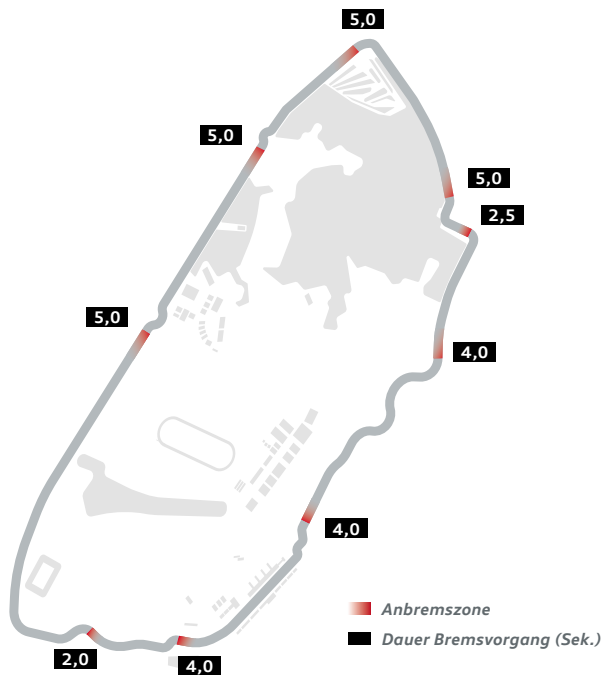

- / Anhand der Streckenskizze von Le Mans lässt sich erkennen, an welchen Stellen der Audi R18 e-tron quattro mit seinem Hybrid-system Energie zurückgewinnt
- / Es ergeben sich neun Anbremszonen zum Rekuperieren

- / Jeder Bremsvorgang dauert nur etwa zwei bis fünf Sekunden
- / Am Kurvenausgang wird die Energie zur Beschleunigung genutzt
- / Maximal darf der Audi R18 e-tron quattro in Le Mans vier Megajoule Hybridenergie pro Runde nutzen

Rekuperierte Hybridenergie

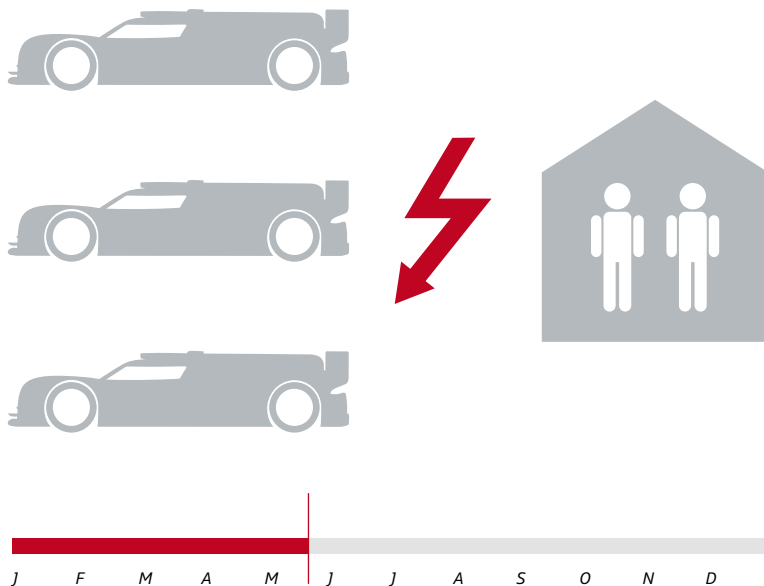

- / Drei Audi R18 e-tron quattro rekuperieren auf der Distanz eines kompletten 24-Stunden-Rennens von Le Mans addiert 4.548 Megajoule¹
- / 4.548 Megajoule entsprechen 1.263 kWh
- / Ein Zweipersonenhaushalt in Deutschland verbraucht pro Jahr 3.248 kWh²
- / Mit der rekuperierten Energie könnte man diesen Haushalt bei gleichmäßigem Energieverbrauch 141,9 Tage versorgen – also vom 1. Januar bis zum 21. Mai

¹ Gemessen an 379 Rennrunden (wie beim Le-Mans-Sieg von Audi 2014)

² Quelle: Energieagentur NRW

Blick in das Cockpit des R18

AMOLED-Bildschirm des
digitalen Rückspiegels

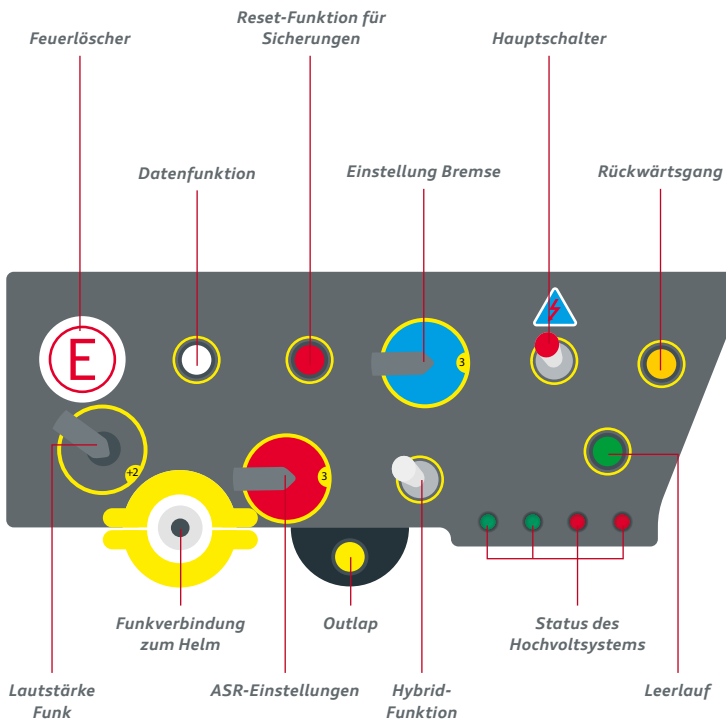
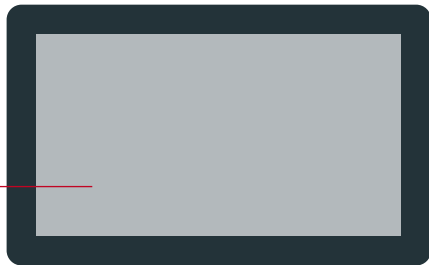

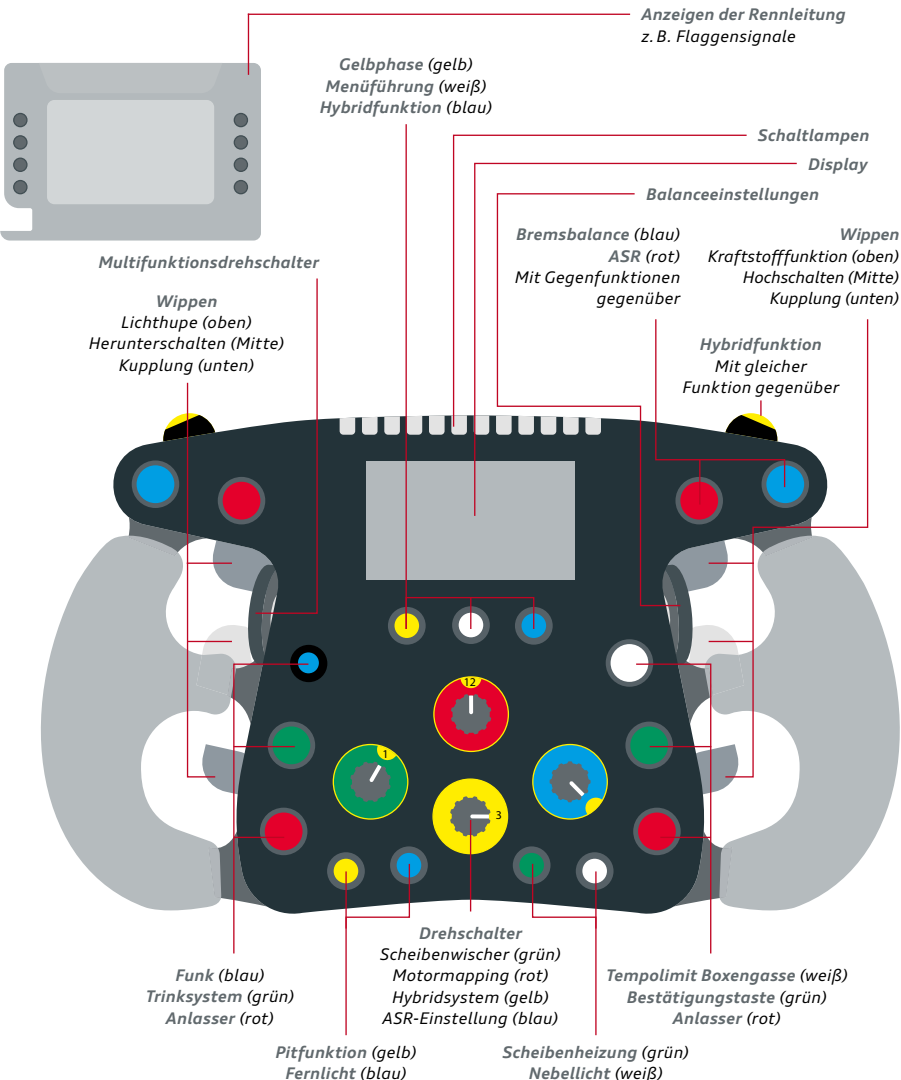

FIA-Langstrecken-Weltmeisterschaft (WEC)

Hersteller in der LMP1-Kategorie

2012



Audi

TOYOTA HYBRID

Toyota

2013



Audi

TOYOTA HYBRID

Toyota

2014



Audi



Porsche

TOYOTA HYBRID

Toyota

2015



Audi

NISSAN
nismo

Nissan



Porsche

TOYOTA HYBRID

Toyota

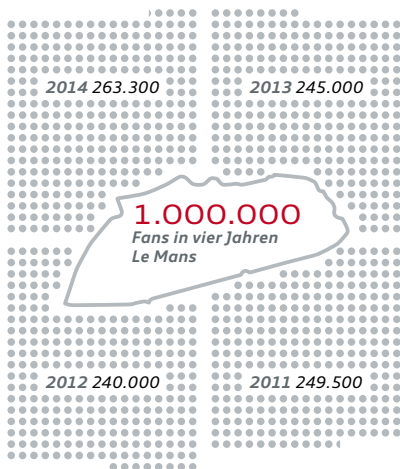

Klassensystem

	LMP1	LMP2
Rennauto	Geschlossener Prototyp	Offener oder geschlossener Prototyp
Kategorien	Mit Energierückgewinnung (Hybrid) für Hersteller und ohne Hybrid für Privatteams	-
Preis	-	Max. 370.000 € Max. 450.000 € (geschlossenes Auto)
Hubraum	Frei (Hybrid) Max. 5.500 cm ³ (ohne Hybrid)	Max. 5.000 cm ³ (Saugmotor) Max. 3.200 cm ³ (Turbo)
Zylinder	Frei	Max. 8 (Saugmotor) Max. 6 (Turbo)
Gewicht	Min. 870 kg (Hybrid) Min. 850 kg (ohne Hybrid)	Min. 900 kg
Länge	Max. 4.650 mm	Max. 4.650 mm
Breite	1.800-1.900 mm	Max. 2.000 mm
Fahrer	Bronze-Fahrer nicht zugelassen	Mindestens 1 Bronze- oder Silber-Fahrer je Auto

Fan-Profil WEC 2014



22% **78%**

Durchschnittsalter
36 38

Soziale Schicht
Mittel- Ober- und
schicht Mittelschicht

Generelle Interessen
Familie, Technik,
Rennfahrer Rennfahrer

Wichtige Links

FIA #FIA

fia.com

[fia](https://www.facebook.com/fia)

[@fia](https://twitter.com/fia)

WEC #WEC

fiawec.com

[fiawec](https://www.facebook.com/fiawec)

[@fiawec](https://twitter.com/fiawec)

ACO

lemans.org

Audi Sport

#AudiSport #WEC #welcomechallenges

audi-motorsport.com

[AudiSport](https://www.facebook.com/AudiSport)

[@Audi_Sport](https://twitter.com/Audi_Sport)

GTE-PRO

GT-Sportwagen mit 2 Türen

-

-

Max. 5.500 cm³ (Saugmotor)

Max. 4.000 cm³ (Turbo)

Frei

Min. 1.245 kg

Max. 4.800 mm

Max. 2.050 mm

Frei

GTE-AM

GT-Sportwagen mit 2 Türen

Autos müssen mindestens 1 Jahr alt
sein

-

Max. 5.500 cm³ (Saugmotor)

Max. 4.000 cm³ (Turbo)

Frei

Min. 1.245 kg

Max. 4.800 mm

Max. 2.050 mm

Mindestens 1 Bronze- oder Silber-Fahrer je Auto

Schlüsselfunktionen im LMP-Programm



*Chris Reinke
Leiter LMP*



*Tristan Summerscale
Projektleiter
Fahrzeugentwicklung*



*Hartmut Diel
Projektleiter
Motorenentwicklung*



*Andreas Roos
Projektleiter
Einsatz*



*Dominic Zeitler
Projektleiter
Versuch*



*Dieter Meissler
Projektleiter
Fahrzeugaufbau*



*Holger Turczynski
Projektleiter
Elektrik, Elektronik, Hybrid*



*Elmar Adler
Partnerschaften*

Audi Sport Team Joest



*Reinhold Joest
Teameigner*



*Ralf Jüttner
Teamdirektor*

Fahrer und Ingenieure

7

Marcel Fässler (CH)

André Lotterer (D)

Benoît Tréluyer (F)



*Leena Gade
Fahrzeugingenieurin
R18 #7*

8

Lucas di Grassi (BR)

Loïc Duval (F)

Oliver Jarvis (GB)



*Justin Taylor
Fahrzeugingenieur
R18 #8*

9

Filipe Albuquerque (P)

Marco Bonanomi (I)

René Rast (D)



*Matthias Huber
Fahrzeugingenieur
R18 #9*

Audi Sport Team Joest

1978

Gegründet

Seit 1999

Partner von Audi

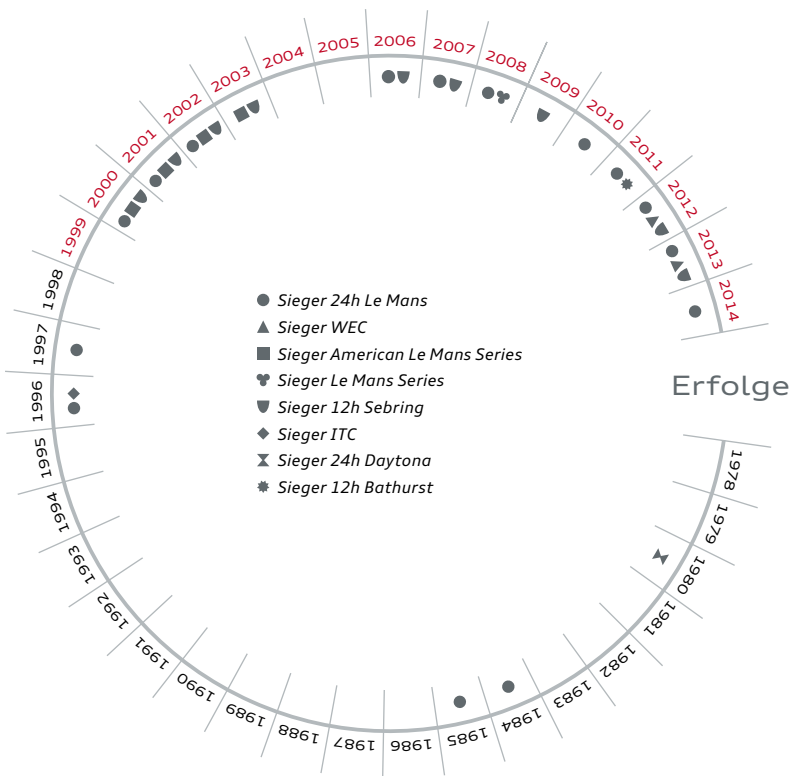



Filipe Albuquerque



1,74 m

* 13.06.1985, Coimbra (P)
▲ Coimbra (P)

Hobbys

 Fußball

 Laufen

Familienstand

 Ledig

Statistik

WEC | Le Mans

Bester
Gesamtplatz
22.
2014

Rennen
2 | 1

Bester Startplatz¹

5. | 5.
2014 2014

Bestes Ergebnis

6. | -
2014

Karriere-Highlights

1994

Kart

2006

1. Formel Renault NEC

1. Formel Renault Eurocup

2009

3. A1 GP

2010

1. Race of Champions

2. Italienische GT

2011



2013

1. 24h Daytona (GT)

 filipealbuquerque.com

 [filipe.albuquerque1](https://www.facebook.com/filipe.albuquerque1)

 [@AlbuquerqueFil](https://twitter.com/AlbuquerqueFil)

¹Fahrzeugstartposition

WEC



Marco Bonanomi



* 12.03.1985, Lecco (I)
▲ Colle Brianza (I)

Hobby



Triathlon

Familienstand



Ledig

Statistik

WEC | Le Mans

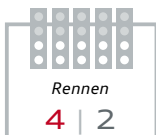

Bester Startplatz¹

2. | 5.
2012 | 2014

Bestes Ergebnis

3. | 3.
2x | 2012

Karriere-Highlights

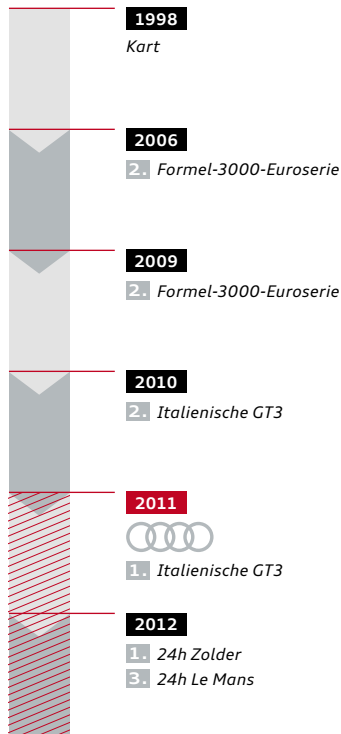

 marcobonanomi.com

 [marcobonanomi.racing](https://www.facebook.com/marcobonanomi.racing)

 @MarcoBonanomi



Lucas di Grassi



1,79 m

* 11.08.1984, São Paulo (BR)
▲ Monaco (MC)

Hobby



Triathlon

Familienstand



Verheiratet

Statistik

WEC | Le Mans

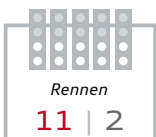

Karriere-Highlights

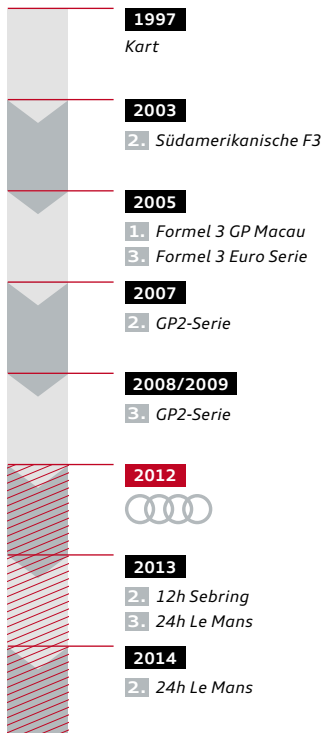

 lucasdigrassi.com.br

 [lucasdigrassiofficial](https://www.facebook.com/lucasdigrassiofficial)

 @LucasdiGrassi

¹Fahrzeugstartposition



Loïc Duval

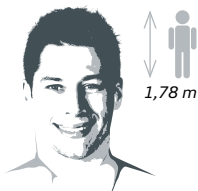

* 12.06.1982, Chartres (F)
▲ Genf (CH)

Hobbys



Familie



Fußball

Familienstand



Verheiratet



2 Söhne

Statistik

WEC | Le Mans

Bester
Gesamtplatz

1.

2013

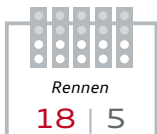

Bester Startplatz¹

1.

1.

2x 2013

Bestes Ergebnis

1.

1.

4x 2013

Karriere-Highlights

1992

Kart

2003

1. Französische
Formel Renault

2009

1. Formel Nippon

2010

1. Japanische Super GT

2011

1. 12h Sebring

2012



2. 12h Sebring

2013

1. 24h Le Mans

1. WEC

 loicduval.com

 Loic.Duval.Official

 @loicduval



Marcel Fässler



* 27.05.1976, Einsiedeln (CH)
▲ Gross (CH)

Hobbys



Mountainbike



Ski

Familienstand



Verheiratet



4 Töchter

Statistik

WEC | Le Mans

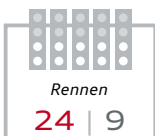

Bester Startplatz¹

1. | **1.**
6x | 2x

Bestes Ergebnis

1. | **1.**
8x | 3x

Karriere-Highlights

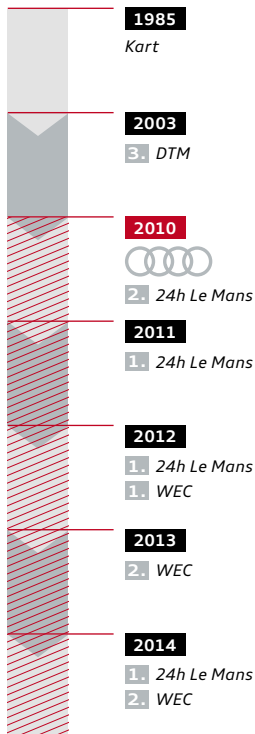

 marcel-faessler.ch

 [pages/Marcel-Faessler/
433092060095169](https://www.facebook.com/pages/Marcel-Faessler/433092060095169)

¹Fahrzeugstartposition



Oliver Jarvis



1,80 m

* 09.01.1984, Burwell (GB)
▲ Burwell (GB)

Hobbys



Fußball



Tennis

Familienstand



Ledig



1 Tochter

Statistik

WEC | Le Mans

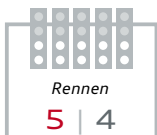

Bester Startplatz¹

2. | **2.**
3x 2013

Bestes Ergebnis

3. | **3.**
4x 2x

Karriere-Highlights

1997

Kart

2005

1. Britische
Formel Renault

2006

2. Britische F3

2007

1. GP Macau

2008



2012

3. 24h Le Mans

2013

1. 12h Sebring
3. 24h Le Mans

 oliverjarvis.com

 [olly.jarvis.73](https://www.facebook.com/olly.jarvis.73)

 [@ollyjarvis](https://twitter.com/ollyjarvis)



André Lotterer



* 19.11.1981, Duisburg (D)
▲ Tokio (J)

Hobbys



Mountainbike



Ledig



Radfahren

Familienstand

Statistik

WEC | Le Mans

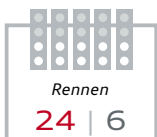

Karriere-Highlights

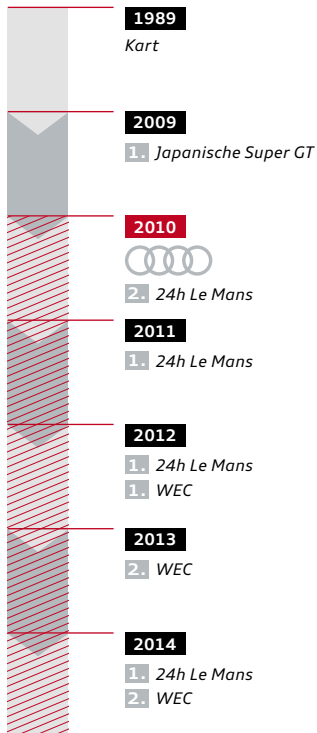

 alotterer

 @andre_lotterer

¹ Fahrzeugstartposition

WEC



René Rast

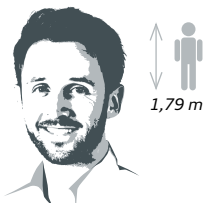

* 26.10.1986, Minden (D)
▲ Frankfurt (D)

Hobbys

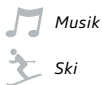

Musik

Ski

Familienstand



Ledig

Statistik

WEC | Le Mans

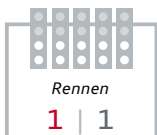

Bester Startplatz¹

20. | 20.
2014 | 2014

Bestes Ergebnis

8. | 8.
2014 | 2014

Karriere-Highlights

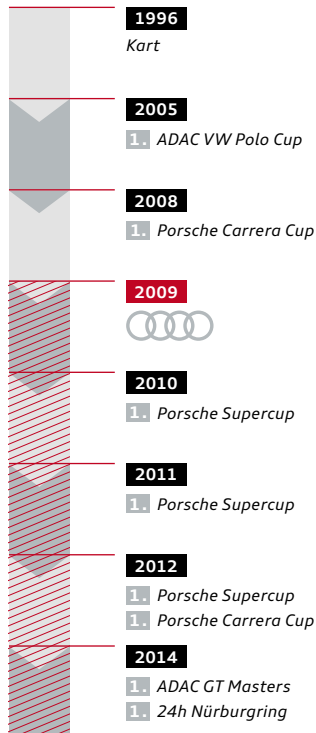

 rene-rast.de

 [pages/René-Rast/438204456206325](https://www.facebook.com/pages/Ren%C3%A9-Rast/438204456206325)

 @renerastracing



Benoît Tréluyer



1,78 m 

* 07.12.1976, Alençon (F)
▲ Gordes (F)

Hobbys

 Motocross

 Mountainbike

Familienstand

 Verheiratet

 1 Sohn

Statistik

WEC | Le Mans

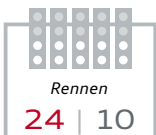

Bester Startplatz¹

1. | 1.
6x | 2x

Bestes Ergebnis

1. | 1.
8x | 3x

Karriere-Highlights

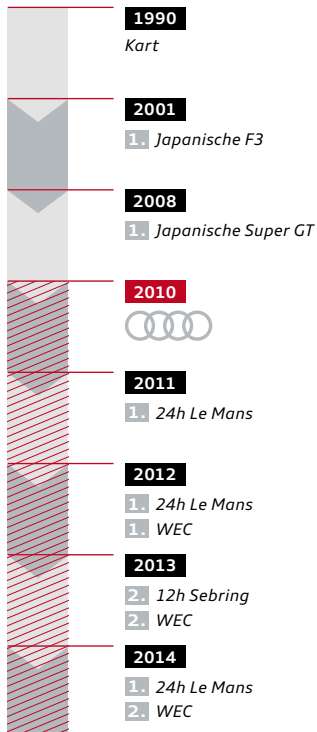

 benoittréluyer.com

 [BenoitTréluyer](https://www.facebook.com/BenoitTréluyer)

 [@BenoitTréluyer](https://twitter.com/BenoitTréluyer)

¹Fahrzeugstartposition

1 6h Silverstone, 12.04.

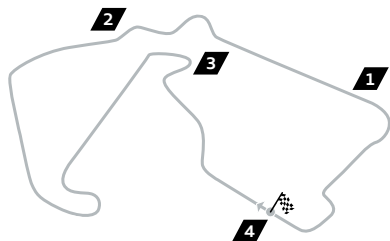

- 1** *Topspeed 279 km/h*
- 2** *Schnellste Kurve 275 km/h*
- 3** *Langsamste Kurve 76 km/h*
- 4** *Zulässige Hybridenergiemenge 2,68 MJ*

5,891 km *Streckenlänge*

ca. 205 km/h
Durchschnittsgeschwindigkeit

36 *Gangwechsel pro Runde*

1.42,774 Min.
Streckenrekord Qualifying
Wurz/Nakajima (Toyota), 2014

1.42,767 Min.
Streckenrekord Rennen
Allan McNish (Audi), 2013

WEC-Erfolge von Audi in Silverstone

- | | | |
|------------------------|------------------------------|---------------------------------------|
| 3 <i>Rennen</i> | 1 <i>Mehrfachsieg</i> | 1 <i>Pole-Position</i> |
| 2 <i>Siege</i> | 4 <i>Podestplätze</i> | 2 <i>Schnellste Rennrunden</i> |

Audi-Marktdaten in Großbritannien 2014

- / Auslieferungsvolumen:
158.800 Einheiten
- / Wachstumsrate gegenüber 2013:
11,8 Prozent
- / Auslieferungsvolumen erstmals
mehr als 150.000 Einheiten
- / Auslieferungsvolumen in den
vergangenen zehn Jahren mehr als
verdoppelt



 *Silverstone Circuit*
 *London*

2 6h Spa-Francorchamps, 02.05.

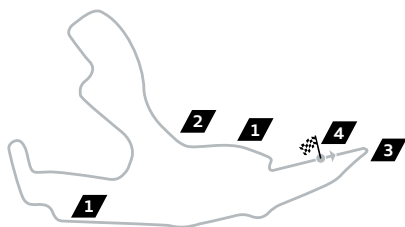

- 1** Topspeed 298 km/h
- 2** Schnellste Kurve 290 km/h
- 3** Langsamste Kurve 66 km/h
- 4** Zulässige Hybridenergiemenge 3,19 MJ

7,004 km Streckenlänge

ca. 215 km/h
Durchschnittsgeschwindigkeit

48 Gangwechsel pro Runde

1.57,884 Min.
Streckenrekord Qualifying
Sébastien Bourdais (Peugeot), 2010

1.59,797 Min.
Streckenrekord Rennen
Franck Montagny (Peugeot), 2010

WEC-Erfolge von Audi in Spa-Francorchamps

3 Rennen	2 Mehrfachsiege	2 Pole-Positions
2 Siege	7 Podestplätze	2 Schnellste Rennrunden

Audi-Marktdaten in Belgien 2014

- / Auslieferungsvolumen:
31.800 Einheiten
- / Wachstumsrate gegenüber 2013:
5 Prozent
- / Audi A3¹ meistverkauftes Modell
und führend in seinem Segment
- / Produktionsstandort: Brüssel



 Circuit de Spa-Francorchamps
 Brüssel

¹ Die Verbrauchs- und Emissionswerte entnehmen Sie der Auflistung auf Seite 151

3 24h Le Mans, 13.–14.06.

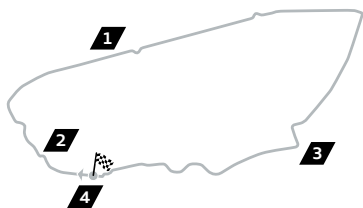

- 1** *Topspeed* 324 km/h
- 2** *Schnellste Kurve* 278 km/h
- 3** *Langsamste Kurve* 76 km/h
- 4** *Zulässige Hybridenergiemenge* 4,00 MJ

13,629 km *Streckenlänge*

ca. 245 km/h
Durchschnittsgeschwindigkeit

72 *Gangwechsel pro Runde*

3.18,513 Min.
Streckenrekord Qualifying
Stéphane Sarrazin (Peugeot), 2008

3.19,074 Min.
Streckenrekord Rennen
Loïc Duval (Peugeot), 2010

Lageplan

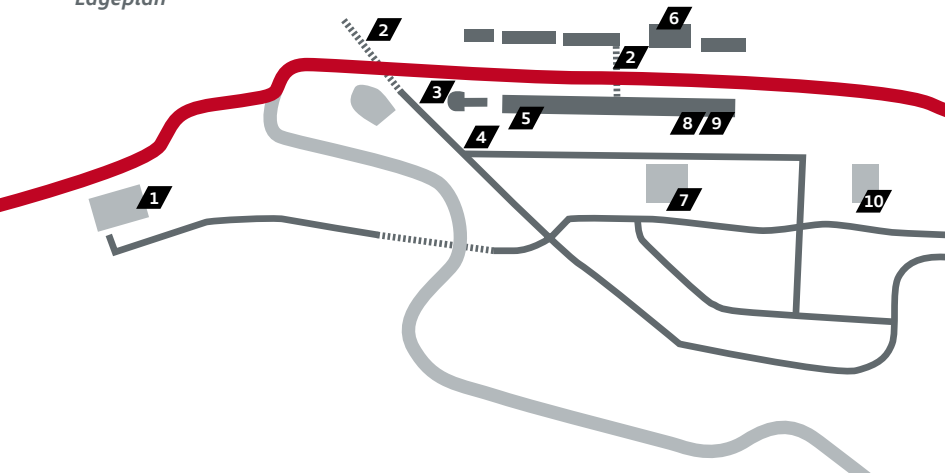

WEC-Erfolge von Audi in Le Mans

3 Rennen

2 Mehrfachsiege

2 Pole-Positions

3 Siege

7 Podestplätze

3 Schnellste Rennrunden

Audi-Marktdaten in Frankreich 2014

/ Auslieferungsvolumen:

57.200 Einheiten

/ Wachstumsrate gegenüber 2013:

0,4 Prozent

/ Audi Marktführer mit A1¹, A3, Q3¹
und Q5¹

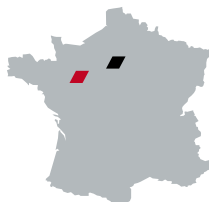

 Circuit des 24 Heures

 Paris

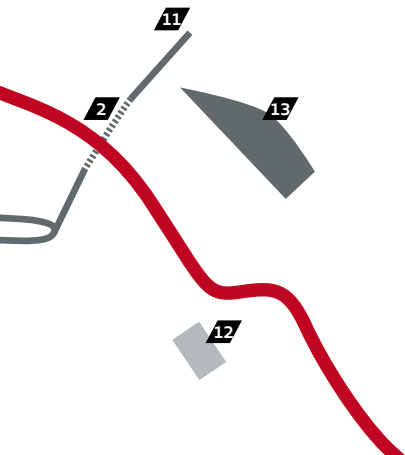

Legende

- 1** Audi Racing Arena, Audi-Pressekonferenz, (Parc du Raccordement)
- 2** Tunnel
- 3** Rennleitung
- 4** Einfahrt Fahrerlager
- 5** Mediacenter
- 6** Audi Racing Club
- 7** Audi Team und Media Hospitality (Paddock)
- 8** Audi Sport Team Joest, Box 44, 45, 46
- 9** Audi Racing Lounges, Nr. 142/143, 145/146
- 10** Audi Racing Garden, Audi Racing Shop, Audi Tower
- 11** Einfahrt Renngelände
- 12** Audi Fan Area
- 13** Museum

¹ Die Verbrauchs- und Emissionswerte entnehmen Sie der Auflistung auf Seite 151

4 6h Nürburgring, 30.08.

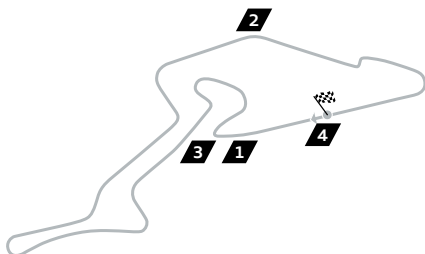

- 1** Topspeed 275 km/h
- 2** Schnellste Kurve 230 km/h
- 3** Langsamste Kurve 72 km/h
- 4** Zulässige Hybridenergiemenge 2,34 MJ

5,148 km Streckenlänge

ca. 185 km/h¹
Durchschnittsgeschwindigkeit

70 Gangwechsel pro Runde

1.39,492 Min.¹
Streckenrekord Qualifying
Gené/Minassian (Peugeot), 2008

1.40,501 Min.¹
Streckenrekord Rennen
Gené/Minassian (Peugeot), 2008



WEC-Erfolge von Audi auf dem Nürburgring

- Rennen
- Mehrfachsiege
- Pole-Positions
- Siege
- Podestplätze
- Schnellste Rennrunden

Audi-Marktdaten in Deutschland 2014

- / Auslieferungsvolumen:
255.600 Einheiten
- / Wachstumsrate gegenüber 2013:
2,2 Prozent
- / Audi Premium-Marktführer
- / Audi A3, Q5 und A6² führend in
ihren Segmenten
- / Produktionsstandorte: Ingolstadt,
Neckarsulm



-  Nürburgring
-  Berlin

5 6h Austin, 19.09.

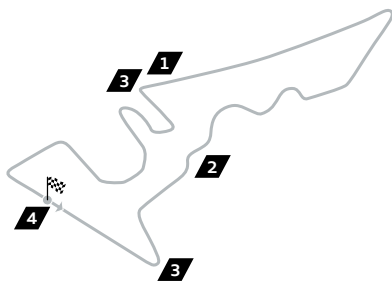

- 1** Topspeed 286 km/h
- 2** Schnellste Kurve 251 km/h
- 3** Langsamste Kurve 68 km/h
- 4** Zulässige Hybridenergiemenge 2,51 MJ

5,513 km Streckenlänge

ca. 180 km/h
Durchschnittsgeschwindigkeit

58 Gangwechsel pro Runde

1.48,355 Min.
Streckenrekord Qualifying
Duval/McNish (Audi), 2013

1.47,375 Min.
Streckenrekord Rennen
Benoît Tréluyer (Audi), 2013

WEC-Erfolge von Audi in Austin

2 Rennen	1 Mehrfachsieg	1 Pole-Position
2 Siege	4 Podestplätze	1 Schnellste Rennrunde

Audi-Marktdaten in den USA 2014

- / Auslieferungsvolumen:
182.000 Einheiten
- / Wachstumsrate gegenüber 2013:
15,2 Prozent
- / Audi Q5 meistverkauftes Modell
- / Audi die am schnellsten wachsende europäische Premium-Marke
- / Audi verzeichnet fünftes Rekordjahr in Folge

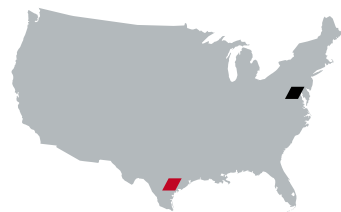

-  Circuit of the Americas
-  Washington D. C.

6 6h Fuji, 11.10.

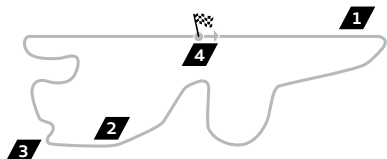

- 1** *Topspeed 301 km/h*
- 2** *Schnellste Kurve 251 km/h*
- 3** *Langsamste Kurve 66 km/h*
- 4** *Zulässige Hybridenergiemenge 2,08 MJ*

4,563 km *Streckenlänge*

ca. 190 km/h
Durchschnittsgeschwindigkeit

44 *Gangwechsel pro Runde*

1.26,577 Min.
*Streckenrekord Qualifying
Lotterer/Tréluyer (Audi), 2013*

1.27,759 Min.
*Streckenrekord Rennen
Mark Webber (Porsche), 2014*

WEC-Erfolge von Audi in Fuji

3 <i>Rennen</i>	0 <i>Mehrfachsiege</i>	1 <i>Pole-Position</i>
0 <i>Siege</i>	2 <i>Podestplätze</i>	1 <i>Schnellste Rennrunde</i>

Audi-Marktdaten in Japan 2014

- / Auslieferungsvolumen:
31.400 Einheiten
- / Wachstumsrate gegenüber 2013:
9,1 Prozent
- / Auslieferungsvolumen erstmals
mehr als 30.000 Einheiten
- / Auslieferungsvolumen seit 2007
jedes Jahr gewachsen und bis
heute verdoppelt



 *Fuji Speedway*
 *Tokio*

7 6h Shanghai, 01.11.

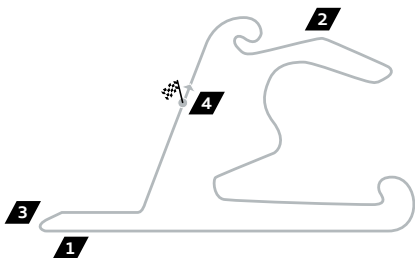

- 1** Topspeed 299 km/h
- 2** Schnellste Kurve 235 km/h
- 3** Langsamste Kurve 56 km/h
- 4** Zulässige Hybridenergiemenge 2,48 MJ

5,451 km *Streckenlänge*

ca. 180 km/h
Durchschnittsgeschwindigkeit

46 *Gangwechsel pro Runde*

1.48,013 Min.
*Streckenrekord Qualifying
Lapierre/Wurz (Toyota), 2013*

1.48,694 Min.
*Streckenrekord Rennen
Sébastien Buemi (Toyota), 2014*

WEC-Erfolge von Audi in Shanghai

3 Rennen	0 Mehrfachsiege	0 Pole-Positions
1 Sieg	3 Podestplätze	1 Schnellste Rennrunde

Audi-Marktdaten in China 2014

- / Auslieferungsvolumen:
578.900 Einheiten
- / Wachstumsrate gegenüber 2013:
17,7 Prozent
- / Audi A6 L meistverkauftes Modell
- / Audi als erster Premium-Hersteller
mehr als 500.000 Auslieferungen
- / Produktionsstandorte: Changchun,
Foshan



 Shanghai International Circuit
 Peking

8 6h Bahrain, 21.11.

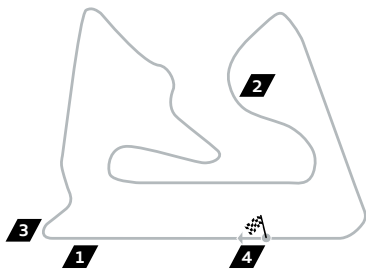

- 1** Topspeed 293 km/h
- 2** Schnellste Kurve 202 km/h
- 3** Langsamste Kurve 61 km/h
- 4** Zulässige Hybridenergiemenge 2,46 MJ

5,412 km Streckenlänge

ca. 190 km/h
Durchschnittsgeschwindigkeit

58 Gangwechsel pro Runde

1.42,449 Min.
Streckenrekord Qualifying
Wurz/Nakajima (Toyota), 2013

1.44,183 Min.
Streckenrekord Rennen
André Lotterer (Audi), 2013

WEC-Erfolge von Audi in Bahrain

3 Rennen	1 Mehrfachsieg	1 Pole-Position
1 Sieg	3 Podestplätze	1 Schnellste Rennrunde

Audi-Marktdaten in Middle East 2014

- / Auslieferungsvolumen:
11.130 Einheiten
- / Wachstumsrate gegenüber 2013:
5 Prozent (Rekord)
- / Auslieferungsvolumen seit 2010
bis heute nahezu verdoppelt
- / Audi Q7¹ meistverkauftes Modell



 Bahrain International Circuit
 Manama

Alle Sieger der 24h Le Mans

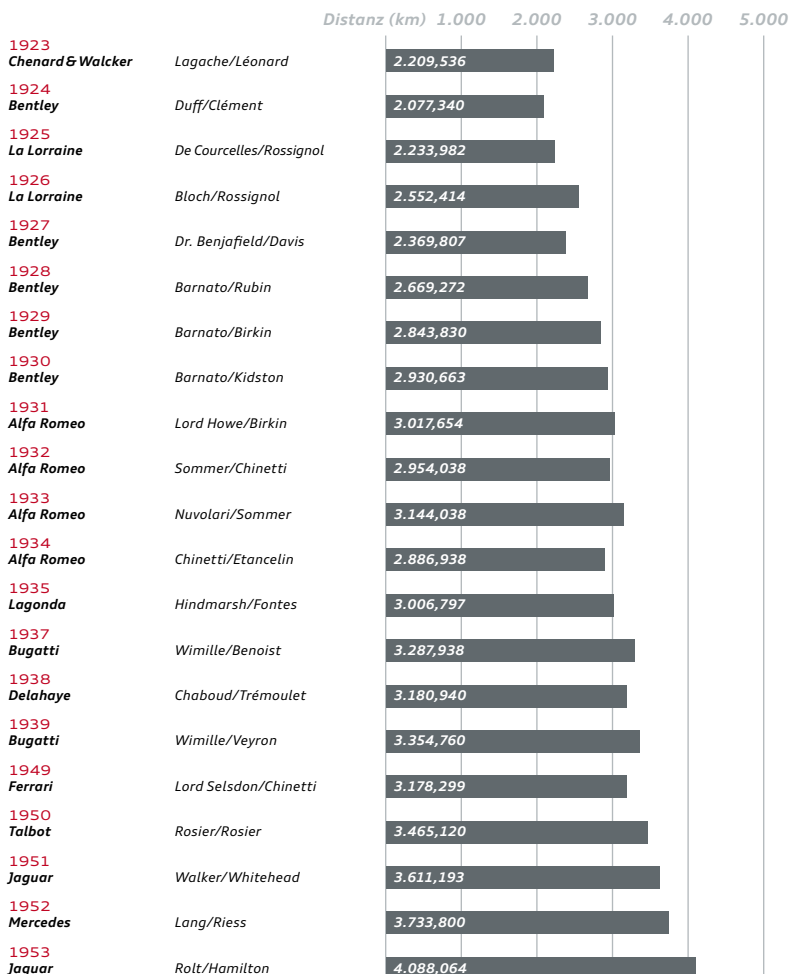

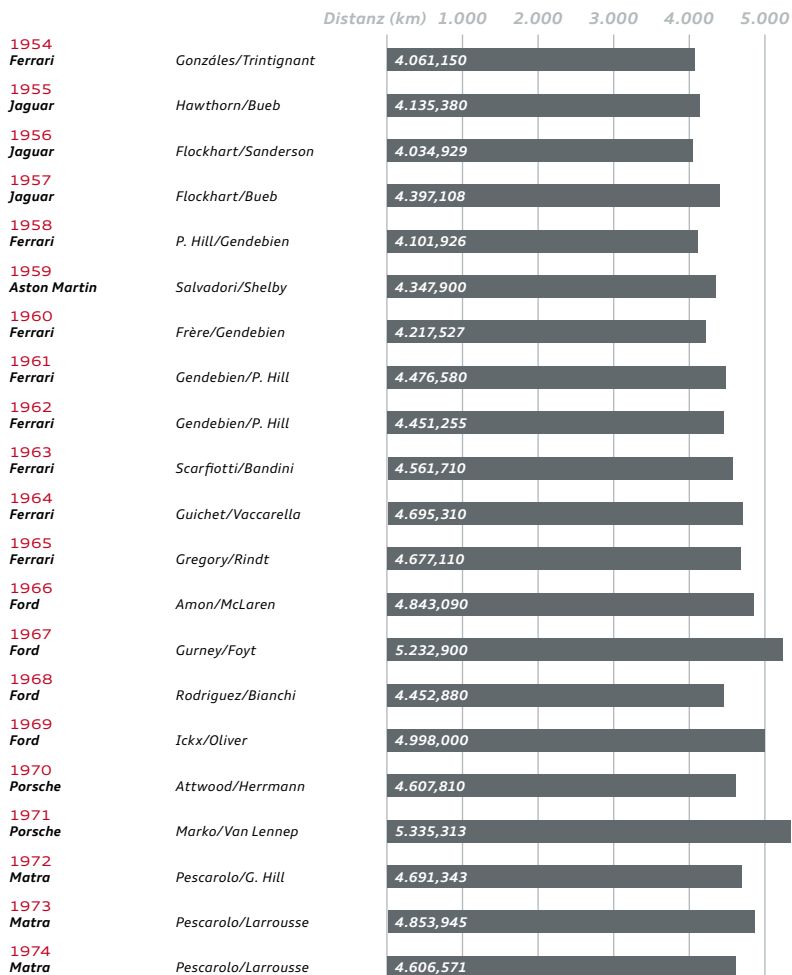

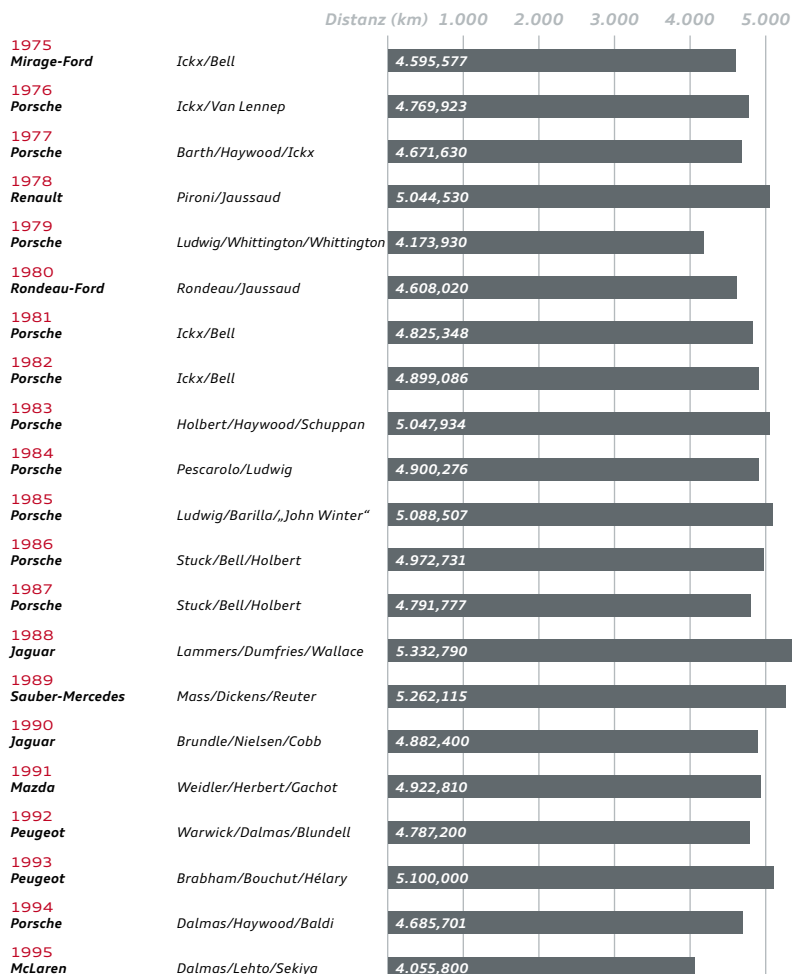

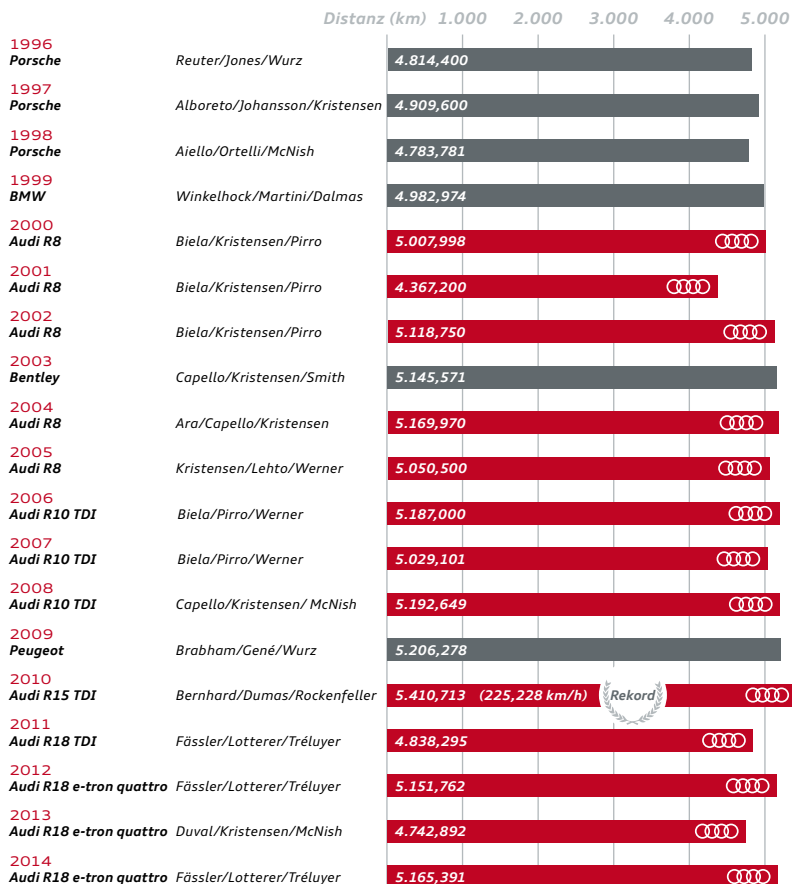

Alle 14 Streckenvarianten der 24h Le Mans

1929 16,340 km

1979 13,626 km

2007 13,629 km

1932 13,492 km

2002 13,650 km

1956 13,461 km

1987 13,535 km

1997 13,605 km

2006 13,650 km

1968 13,469 km

1972 13,640 km

1990 13,600 km



..... 1923 17,262 km

■ 2007-2015 13,629 km

● Umbauten

1986 13,528 km

LMP-Titel und große LMP-Langstreckensiege von Audi

Meisterschaft/ Einzelrennen	 Audi R8	 Audi R10 TDI	 Audi R15 TDI	 Audi R18 TDI ¹ / e-tron quattro ²
WEC (2)				● ● 2012–2013 ²
ALMS (9)	● ● ● ● ● ● ● ● ● 2000–2006 ¹	● ● ● 2006 ¹ –2008		
ELMS (3)	● ● 2001, 2004	● 2008		
24h Le Mans (13)	● ● ● ● ● 2000–2002 2004–2005	● ● ● 2006–2008	● 2010	● ● ● ● 2011 ¹ 2012–2014 ²
12h Sebring (11)	● ● ● ● ● ● ● ● ● 2000–2005	● ● 2006–2007	● 2009	● ● 2012 ¹ 2013 ²
„Petit Le Mans“ (9)	● ● ● ● ● ● ● ● ● 2000–2005	● ● ● ● 2006–2008		

Alle Siege der LMP-Rennwagen von Audi 1999–2014

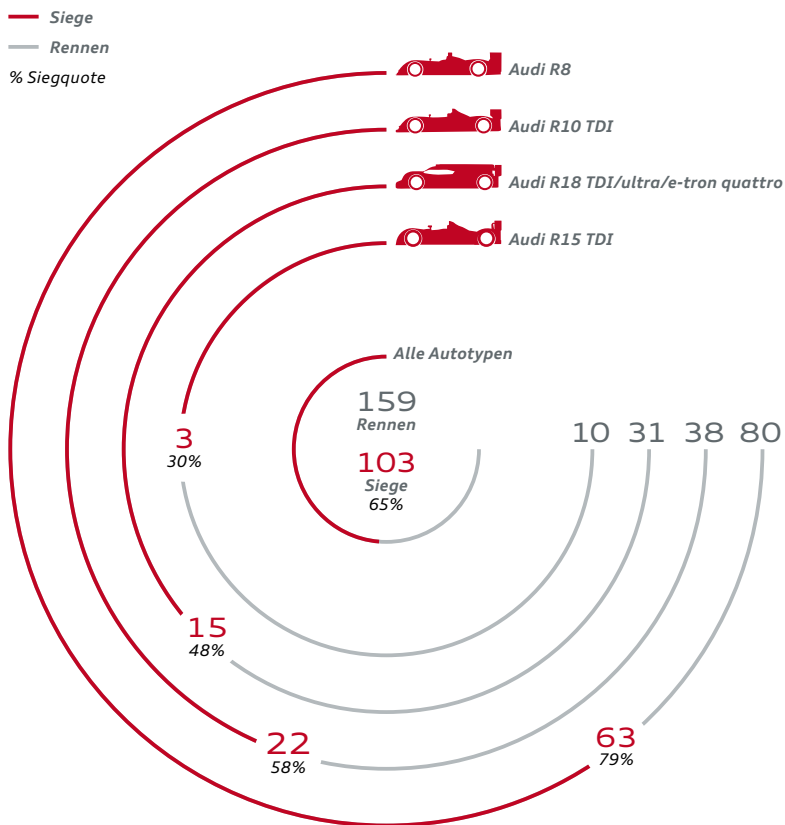

Partner von Audi Sport in der WEC



Weitere Partner



alpinestars.com

Audi
Top Service®

audi.de



gerolsteiner.de



hofmuehl.de



oz-racing.de

DTM

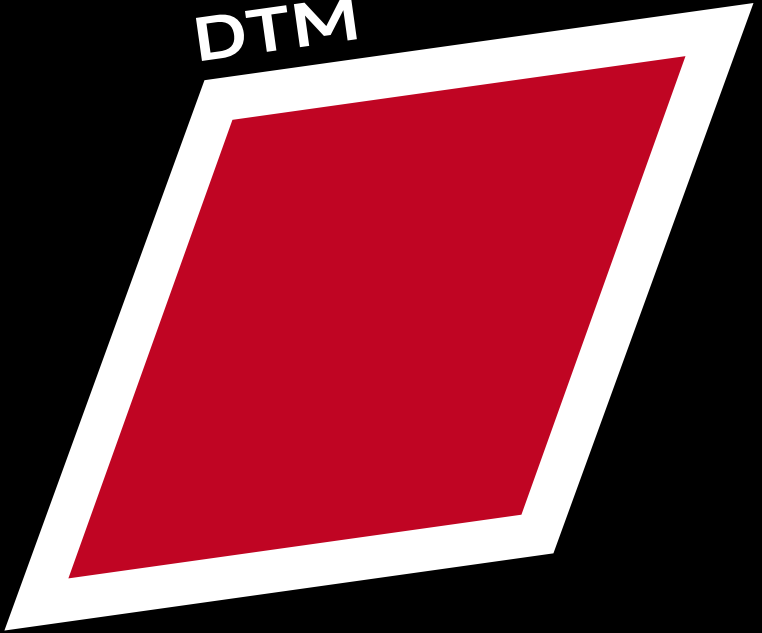



Inhalt

Audi RS 5 DTM: Sicherheitselemente.....	76
Drag Reduction System (DRS).....	78
Blick in das Cockpit des RS 5 DTM.....	80
Format der DTM-Wochenenden.....	82
Alle DTM-Jahre.....	84
Der DTM-Durchschnitts-Champion.....	85
Schlüsselfunktionen im DTM-Programm.....	86
Teams und Fahrer.....	88
Audi Sport Team Abt Sportsline.....	89
Audi Sport Team Phoenix.....	90
Audi Sport Team Rosberg.....	91
Die acht Fahrer im Porträt.....	92
Die Strecken im Überblick.....	100
Titel und Erfolge in der DTM.....	109
Beste Audi-Fahrer je Saison.....	110
Siegquote nach Fahrzeugtypen.....	111
Partner von Audi Sport in der DTM.....	112

Audi RS 5 DTM: Sicherheitselemente

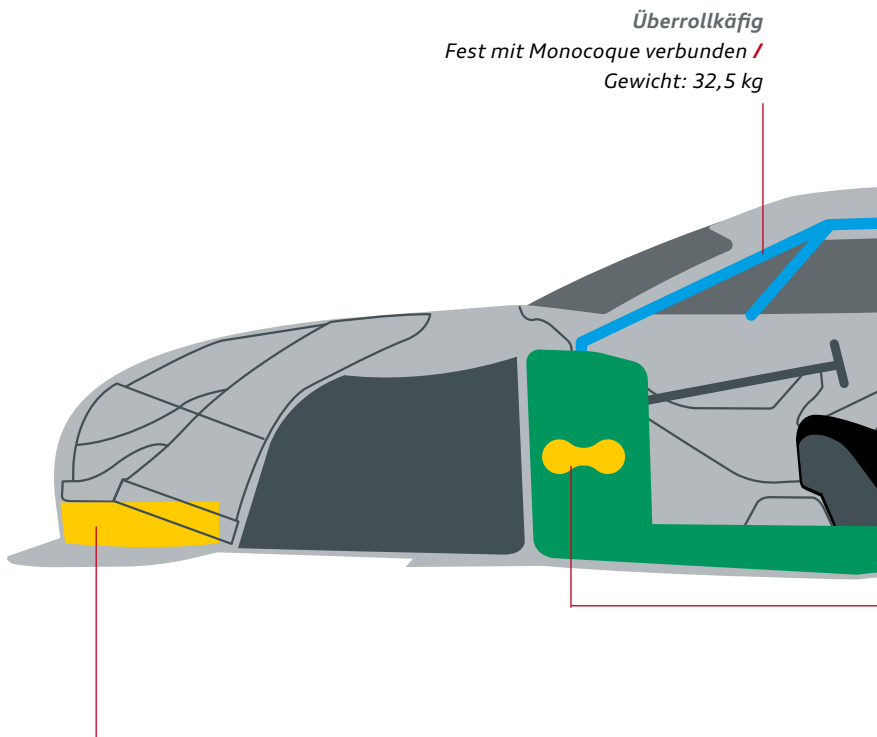

Überrollkäftig

Fest mit Monocoque verbunden /

Gewicht: 32,5 kg

Crashbox vorn

*Bei einem Frontalaufprall mit 54 km/h darf
der Brustkorb des Fahrers einer Belastung
von maximal 60 g ausgesetzt sein*

Monocoque

Komplett aus Karbon /

Gewicht: 126 kg /

120-Liter-Tank integriert

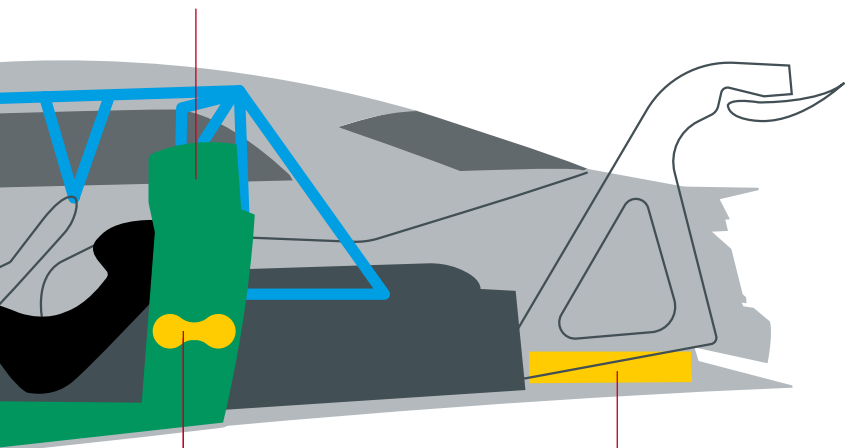

Crashboxen seitlich

**Gesamte Seitenwand muss
beim Seitenaufpralltest einer
Kraft von 360 kN widerstehen –
das entspricht 36 Tonnen**

Crashbox hinten

**Länge: 65 cm (vorn eben-
so) / Muss einen Crash-
test mit einer Geschwin-
digkeit von rund 50 km/h
gegen eine starre Wand
überstehen**

Drag Reduction System (DRS)

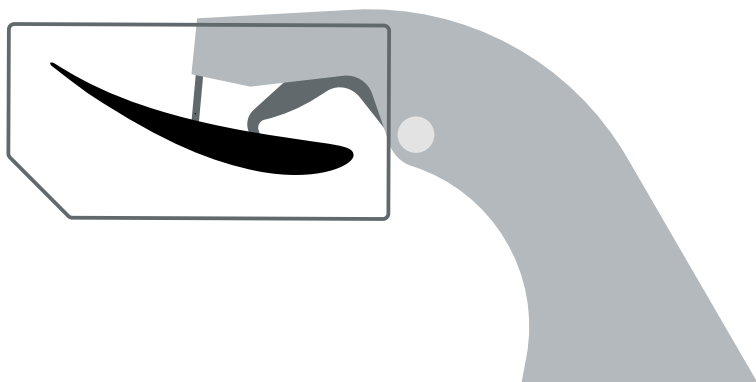
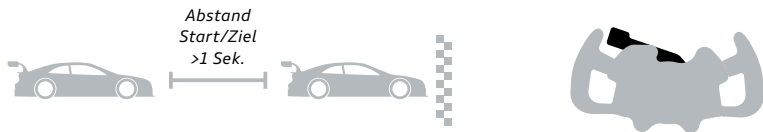

- / Klappbarer Heckflügel in Normalstellung
- / Höherer Luftwiderstand sorgt für Anpressdruck in den Kurven
- / Abstand zum Vordermann wird bei Start/Ziel gemessen
- / Ist der Abstand größer als eine Sekunde: keine DRS-Freigabe

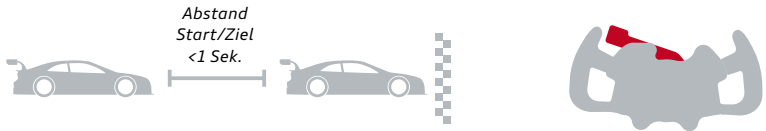

- / Ist der Abstand geringer als eine Sekunde: DRS-Freigabe
- / DRS darf während der Folgerunde bis zu dreimal benutzt werden
- / Aktivierung erfolgt durch einen Zughebel am Lenkrad
- / Durch geringeren Luftwiderstand auf den Geraden erhöht sich der Topspeed

Blick in das Cockpit des RS 5 DTM

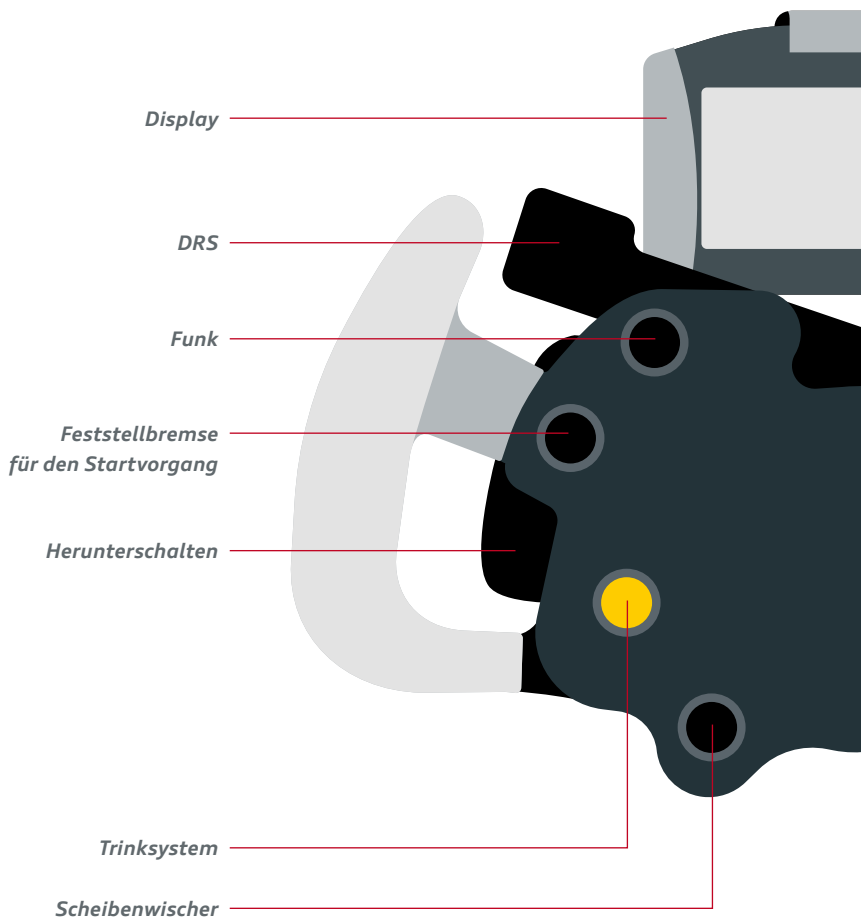

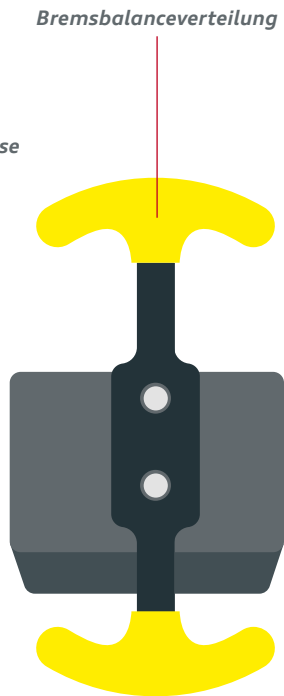
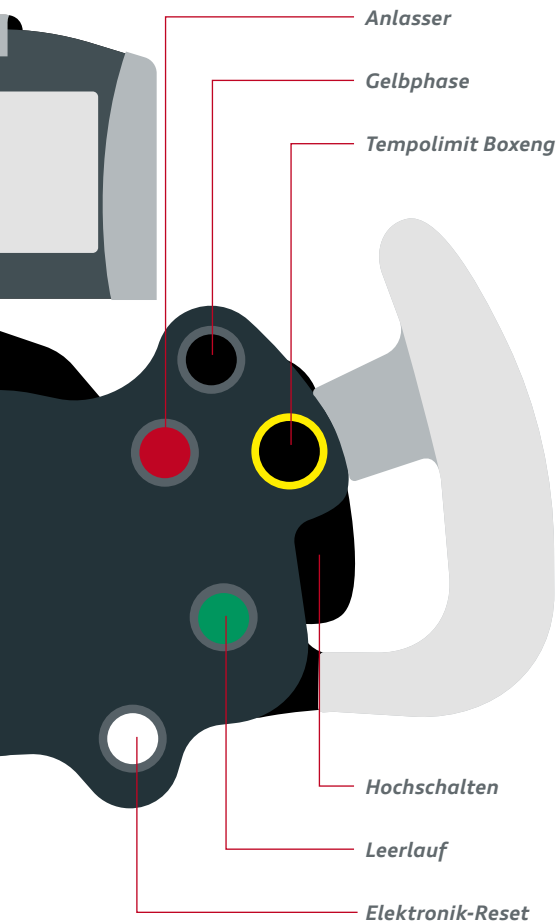

Format der DTM-Wochenenden

Qualifying (jeweils vor Rennen 1 und 2)

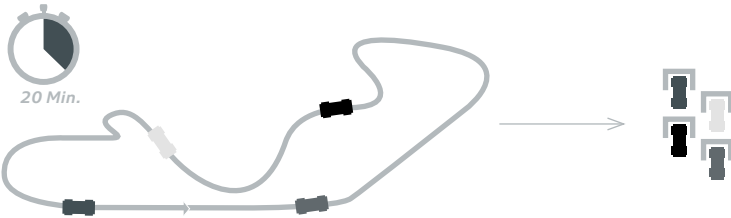

Rennen 1 (Samstag)

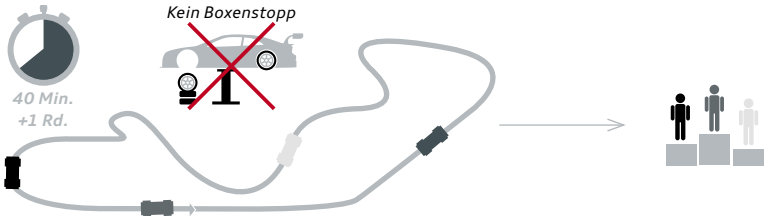

Rennen 2 (Sonntag)

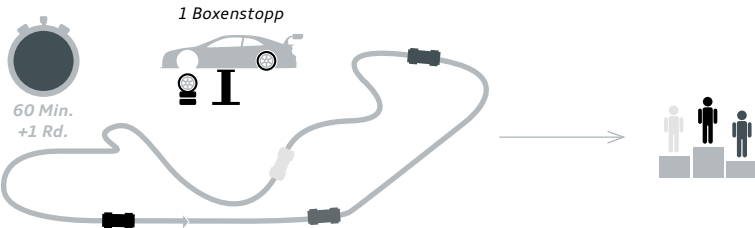

Weitere Regeln

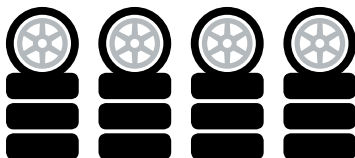

Reifen
Vier Sätze Slicks pro Auto pro Wochenende für Qualifying und Rennen



Performance-Gewichte
Abhängig von den Platzierungen der Fahrer wird das Gesamtgewicht aller Autos der drei Marken für das folgende Rennen individuell angepasst: erhöht, verringert oder es bleibt gleich

Titel



Fahrer



Team



Hersteller

Wichtige Links

DMSB

 [dmsb.de](#)

DTM #DTM

 [dtm.com](#)

 [DTM](#)

 [@dtm](#)

Punktesystem

1. Platz	2. Platz	3. Platz	4. Platz	5. Platz
25	18	15	12	10
6. Platz	7. Platz	8. Platz	9. Platz	10. Platz
8	6	4	2	1

Audi Sport

#AudiSport #DTM
#welcomechallenges

 [audi-motorsport.com](#)

 [AudiSport](#)

 [@Audi__Sport](#)

Alle DTM-Jahre

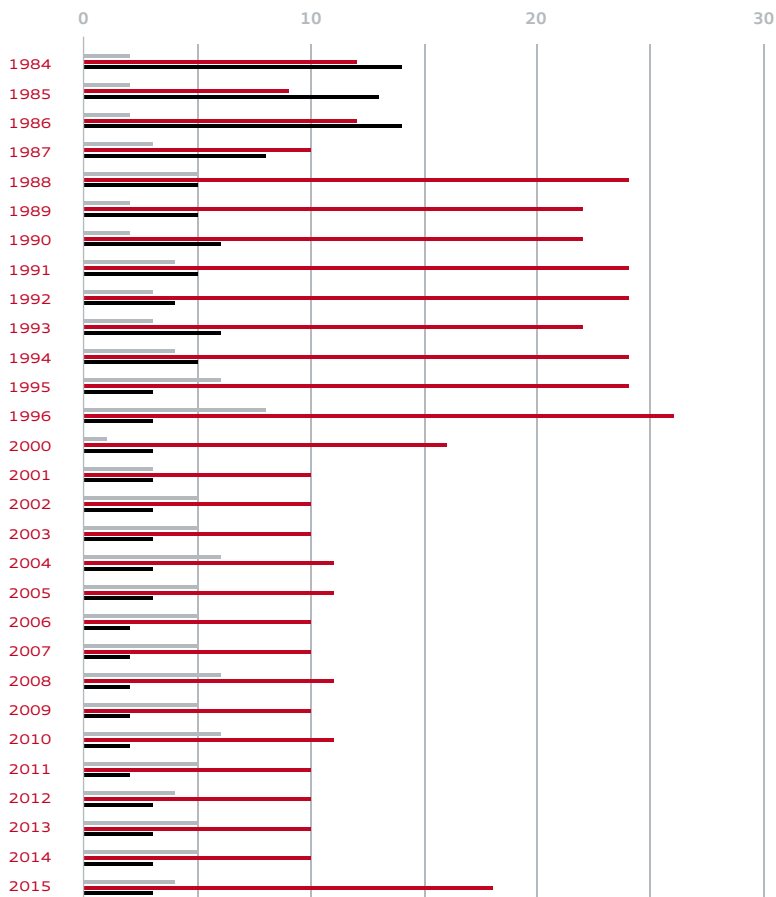

— Austragungsländer

— Rennen

— Teilnehmende Marken

Der DTM-Durchschnitts-Champion...

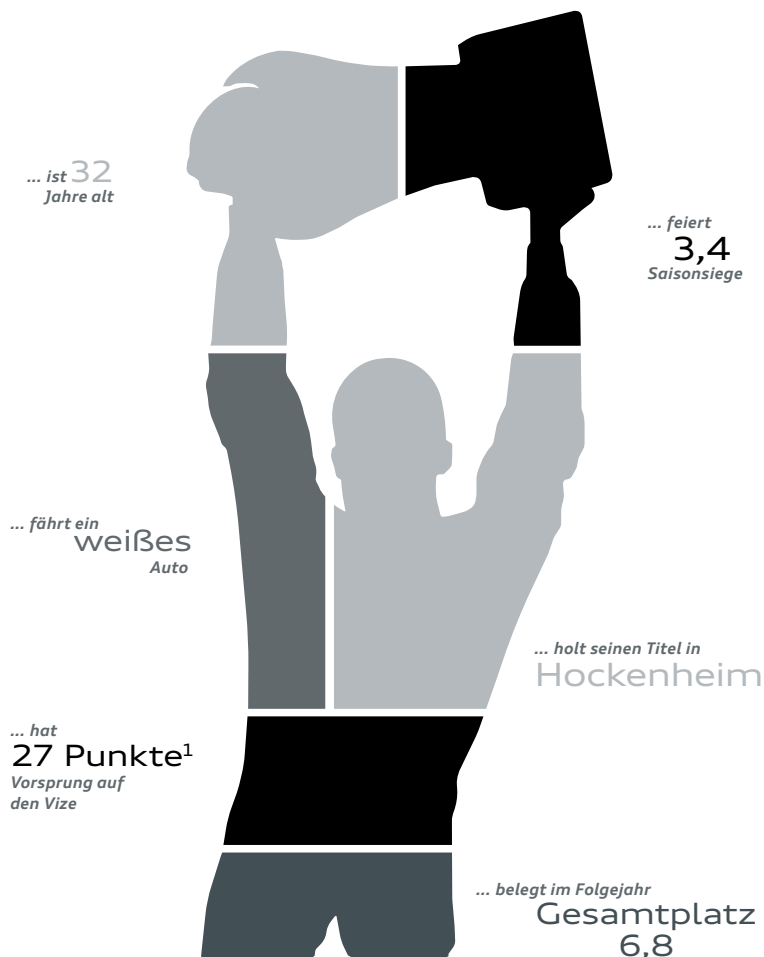

¹Umgerechnet auf das aktuelle Punktesystem

Schlüsselfunktionen im DTM-Programm



*Dieter Gass
Leiter DTM*



*Stefan Gugger
Projektleiter Fahrzeug-
entwicklung*



*Jürgen Hofbauer
Technischer Koordinator*



*Dr. Andrea Milocco
Projektleiter Motor*



*Florian Modlinger
Projektleiter Test & Technik*



*Volker Nossek
Projektleiter Organisation*



*Oliver Straube
Partnerschaften*

Audi Sport Team Abt Sportsline



Hans-Jürgen Abt
Teamchef



Harry Unflath
Leiter Marketing



Thomas Biermaier
Sportdirektor



Michael Seifert
Teammanager

Audi Sport Team Phoenix



Ernst Moser
Teamchef



Chris van Rutten
Technischer Leiter



Dirk Theimann
Teammanager

Audi Sport Team Rosberg



Arno Zensen
Teamchef



Ossi Oikarinen
Technischer Direktor



Kimmo Liimatainen
Teammanager



Ramon Hämmerle
Teamkoordinator

Teams und Fahrer

Audi Sport Team Abt Sportsline

 **EKS**
Mattias Ekström

Florian Modlinger
Fahrzeugingenieur



Red Bull Audi RS 5 DTM

#5

 **MOL**
Miguel Molina

Markus Michelberger
Fahrzeugingenieur



Teufel Audi RS 5 DTM

#17

 **TAM**
Adrien Tambay

Nicola Palarchi
Fahrzeugingenieur



Playboy Audi RS 5 DTM

#27

 **MOR**
Edoardo Mortara

Franco Chiocchetti
Fahrzeugingenieur



Castrol EDGE Audi RS 5 DTM

#48

Audi Sport Team Phoenix

 **TSC**
Timo Scheider

Laurent Fedacou
Fahrzeugingenieur



AUTO TEST Audi RS 5 DTM

#10

 **ROC**
Mike Rockenfeller

Jürgen Jungklaus
Fahrzeugingenieur



Schaeffler Audi RS 5 DTM

#99

Audi Sport Team Rosberg

 **MUE**
Nico Müller

Karl Jennings
Fahrzeugingenieur



Audi Financial Services Audi RS 5 DTM

#51

 **GRE**
Jamie Green

Erich Baumgärtner
Fahrzeugingenieur



Hoffmann Group Audi RS 5 DTM

#53

Audi Sport Team Abt Sportsline

1991
Gegründet

Seit 1996
Partner von Audi

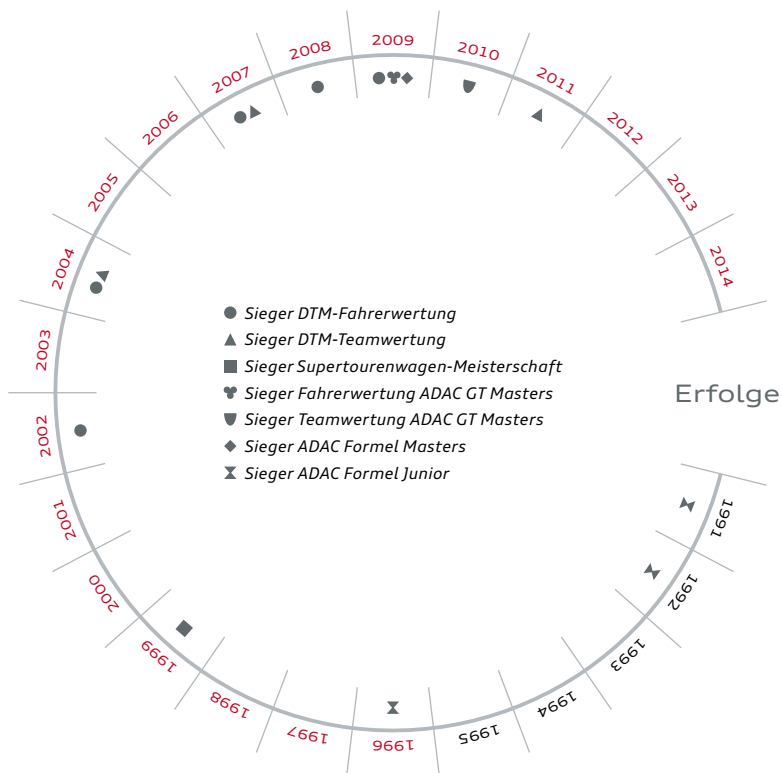

Erfolge

Audi Sport Team Phoenix

1999
Gegründet

Seit 2006
Partner von Audi

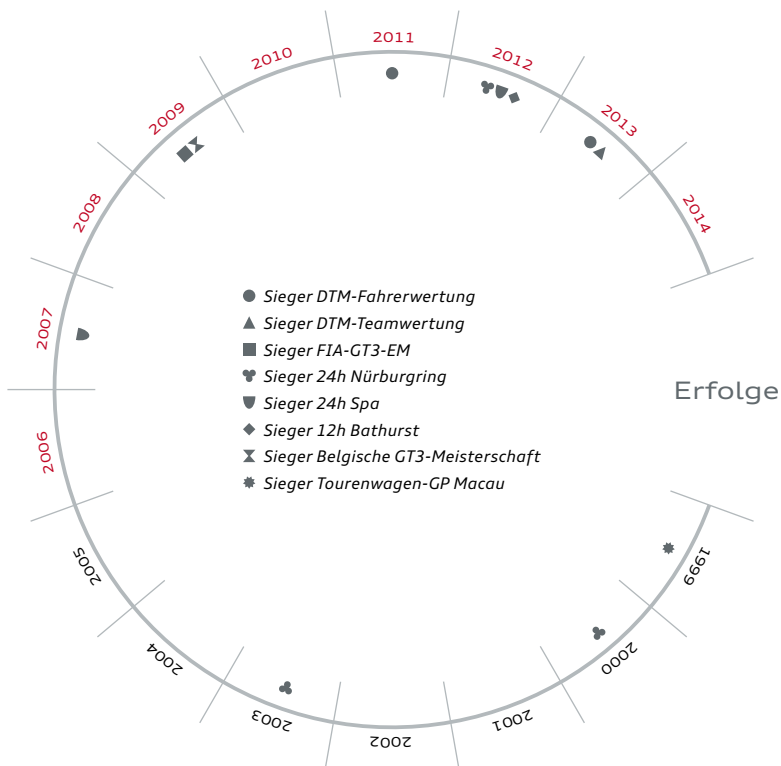

Audi Sport Team Rosberg

1994
Gegründet

Seit 2006
Partner von Audi

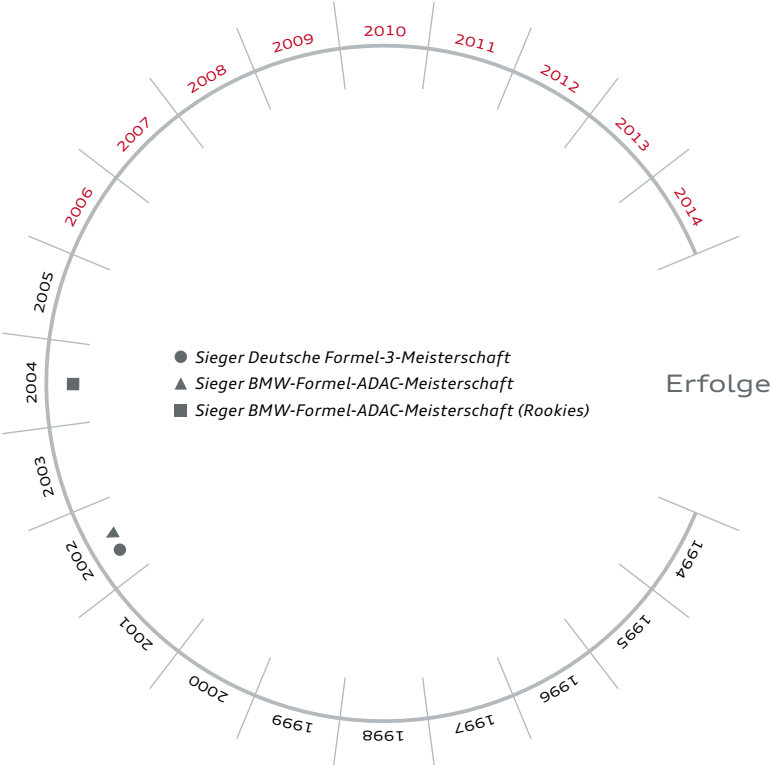



#5 Mattias Ekström



1,83 m

* 14.07.1978, Falun (S)
 ▲ Going (A)

Hobbys



Radfahren



Ski

Familienstand



Partnerschaft



1 Sohn, 1 Tochter

Statistik DTM

Bester
Gesamtplatz

1.
2x

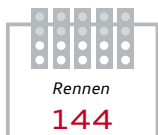

Bester Startplatz

1.
19x

Bestes Ergebnis

1.
19x

Karriere-Highlights

1993

Kart

1999



1. Schwed. Tourenwagen

2004

1. DTM

2006

1. Race of Champions

2007

1. DTM

1. Race of Champions

2009

1. Race of Champions

2014

2. DTM

1. World RX Schweden



mattiasekstromracing



mattiasekstrom.com



mattiasekstrom.racing



@mattiasekstroem



#53 Jamie Green



1,78 m

* 14.06.1982, Leicester (GB)
▲ Monaco (MC)

Hobbys



Fußball



Golf

Familienstand



Verheiratet



2 Söhne

Statistik DTM

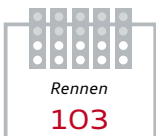

Bester Startplatz

1.
7x

Bestes Ergebnis

1.
8x

Karriere-Highlights

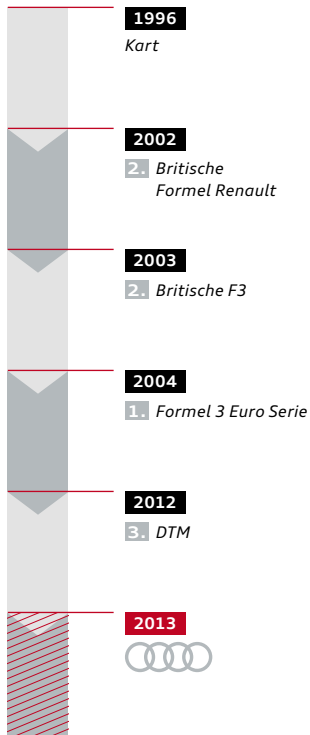

 jamiegreenracing.co.uk

 @JamieGreen_

DTM



#17 Miguel Molina



1,75 m

* 17.02.1989, Barcelona (E)

▲ Lloret de Mar (E)

Hobby



Slotcars

Familienstand



Partnerschaft

Statistik DTM

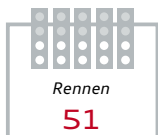

Bester Startplatz

1.
3x

Bestes Ergebnis

2.
2014

Karriere-Highlights

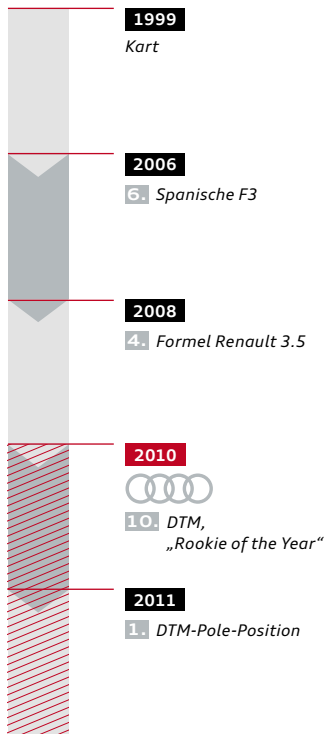

 miguelmolina.net

 Miguel.Molina.racing

 @MiguelMolinaM2



#48 Edoardo Mortara



1,82 m

* 12.01.1987, Genf (CH)
▲ Genf (CH)

Hobbys



Ski



Wakeboarden

Familienstand



Verheiratet

Statistik DTM

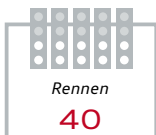

Bester Startplatz

1.
2012

Bestes Ergebnis

1.
2x

Karriere-Highlights

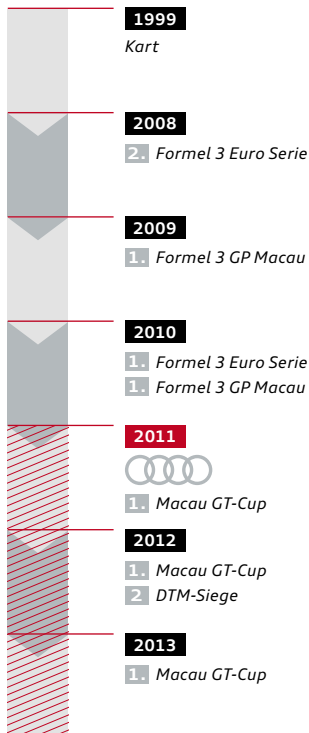

 edomortara

 edoardomortara.com

 edomortararacing

 @edomortara

DTM



#51 Nico Müller



1,85 m

* 25.02.1992, Thun (CH)

📍 Bern (CH)

Hobbys



Kart



Radfahren

Familienstand



Partnerschaft

Statistik DTM

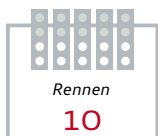

Karriere-Highlights

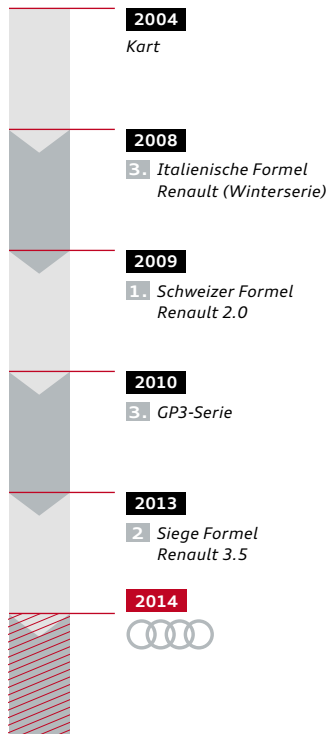

 [nicosmueller](#)

 [nicomueller.ch](#)

 [NicoMuellerOfficial](#)

 [@nico_mueller](#)



#99 Mike Rockenfeller

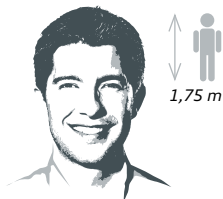

* 31.10.1983, Neuwied (D)
▲ Landschlacht (CH)

Hobbys



Oldtimer



Radfahren

Familienstand



Verheiratet



1 Sohn

Statistik DTM



Bester Startplatz

1.
4x

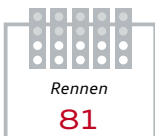

Bestes Ergebnis

1.
3x

Karriere-Highlights

1995

Kart

2004

1. Porsche Carrera Cup

2006

1. 24h Nürburgring

2007



2008

1. Le Mans Series

2010

1. 24h Le Mans

2012

3. 24h Le Mans

2013

1. DTM

 [mike_rockenfeller](#)

 [mike-rockenfeller.de](#)

 [mikerockenfeller](#)

 [@m_rockenfeller](#)



#10 Timo Scheider



* 10.11.1978, Lahnstein (D)
 🏠 Lochau (A)

Hobbys



Familie



Kart

Familienstand



Verlobt



1 Sohn

Statistik DTM

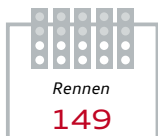

Bester Startplatz

1.
11x

Bestes Ergebnis

1.
6x

Karriere-Highlights

1989

Kart

1995

1. Deutsche Formel
Renault 1800

1997

2. Deutsche F3

2003

1. 24h Nürburgring

2005

2. FIA GT
1. 24h Spa

2006



2008

1. DTM

2009

1. DTM



#27 Adrien Tambay

Karriere-Highlights

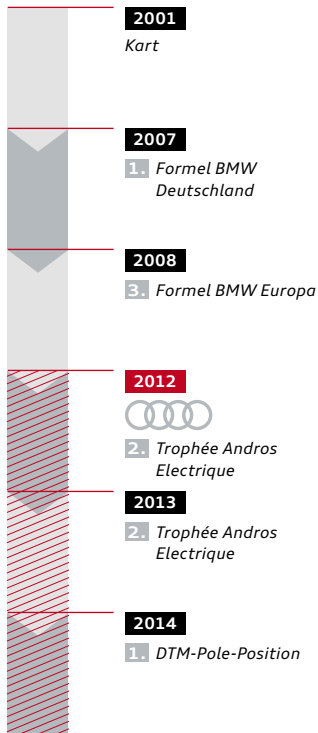

 [adrientambay](#)

 [adrientambay.com](#)

 [adrientambayofficial](#)

 [@TambayRacing](#)



1,81 m

* 25.02.1991, Paris (F)
▲ London (GB)

Hobbys

 Familie

 Fitness

Familienstand

 Ledig

Statistik DTM

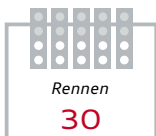

1 Hockenheim, 02.–03.05.

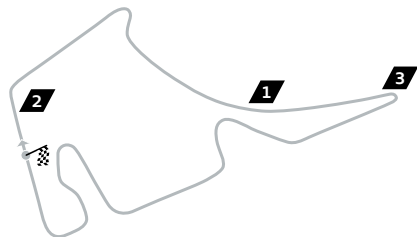

- 1** *Topspeed* 258 km/h
- 2** *Schnellste Kurve* 180 km/h
- 3** *Langsamste Kurve* 65 km/h

4,574 km *Streckenlänge*

ca. 180 km/h
Durchschnittsgeschwindigkeit

32 *Gangwechsel pro Runde*

1.32,244 Min.
Streckenrekord Qualifying
Mattias Ekström (Audi), 2008

1.32,532 Min.
Streckenrekord Rennen
Martin Tomczyk (BMW), 2014

DTM-Erfolge von Audi beim Hockenheim-Auftakt¹

18 *Veranstaltungen*
35 *gesamt mit Finale*

22 *Rennen*
42 *gesamt mit Finale*

4 *Siege*
10 *gesamt mit Finale*

4 *Mehrfachsiege*
9 *gesamt mit Finale*

20 *Podestplätze*
47 *gesamt mit Finale*



7 *Pole-Positions*
18 *gesamt mit Finale*

3 *Schnellste Rennrunden*
7 *gesamt mit Finale*

Audi Zentrum in der Nähe

Audi Zentrum Heidelberg
Hebelstraße 12
D-69115 Heidelberg
Telefon +49 6221 535200



 *Hockenheimring*
 *Audi Zentrum (Entfernung 21 km)*

2 Lausitzring, 30.–31.05.

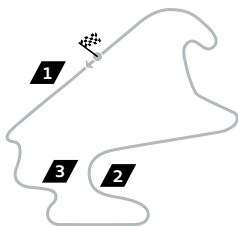

- 1** Topspeed 239 km/h
- 2** Schnellste Kurve 150 km/h
- 3** Langsamste Kurve 75 km/h

DTM-Erfolge von Audi auf dem Lausitzring

- 16** Veranstaltungen
- 15** Rennen
- 2** Siege
- 1** Mehrfachsieg
- 15** Podestplätze
- 2** Pole-Positions
- 6** Schnellste Rennrunden

3,478 km Streckenlänge

ca. 160 km/h
Durchschnittsgeschwindigkeit

24 Gangwechsel pro Runde

1.17,463 Min.
Streckenrekord Qualifying
Gary Paffett (Mercedes-Benz), 2013

1.18,268 Min.
Streckenrekord Rennen
Mike Rockenfeller (Audi), 2013

Audi Zentrum in der Nähe

Audi Zentrum Dresden
Hamburger Straße 28
D-01067 Dresden
Telefon +49 351 4920100



-  EuroSpeedway Lausitz
-  Audi Zentrum (Entfernung 65 km)

3 Norisring, 27.–28.06.

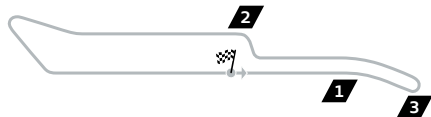

- 1** *Topspeed 245 km/h*
- 2** *Schnellste Kurve 110 km/h*
- 3** *Langsamste Kurve 51 km/h*

2,300 km *Streckenlänge*

ca. 175 km/h
Durchschnittsgeschwindigkeit

22 *Gangwechsel pro Runde*

47,785 Min.
Streckenrekord Qualifying
Bruno Spengler (Mercedes-Benz), 2008

48,446 Min.
Streckenrekord Rennen
Bruno Spengler (Mercedes-Benz), 2008

DTM-Erfolge von Audi auf dem Norisring

- 17** *Veranstaltungen*
- 20** *Rennen*
- 3** *Siege*
- 1** *Mehrfachsieg*
- 15** *Podestplätze*
- 3** *Pole-Positions*
- 5** *Schnellste Rennrunden*

Audi Zentrum in der Nähe

Audi Zentrum Nürnberg-
Marienberg GmbH
Marienbergstraße 88
D-90411 Nürnberg
Telefon +49 911 54030



-  *Norisring*
-  *Audi Zentrum (Entfernung 9 km)*

4 **Zandvoort, 11.-12.07.**

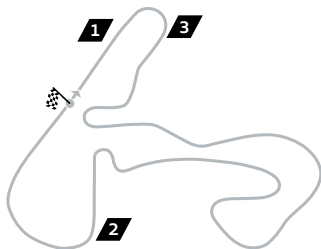

- 1** *Topspeed 246 km/h*
- 2** *Schnellste Kurve 180 km/h*
- 3** *Langsamste Kurve 83 km/h*

DTM-Erfolge von Audi in Zandvoort

- 14** *Veranstaltungen*
- 14** *Rennen*
- 8** *Siege*
- 4** *Mehrfachsiege*
- 25** *Podestplätze*
- 8** *Pole-Positions*
- 6** *Schnellste Rennrunden*

4,307 km *Streckenlänge*

ca. 170 km/h
Durchschnittsgeschwindigkeit

25 *Gangwechsel pro Runde*

1.30,449 Min.
*Streckenrekord Qualifying
Pascal Wehrlein (Mercedes-Benz), 2014*

1.32,296 Min.
*Streckenrekord Rennen
Marco Wittmann (BMW), 2013*

Audi Zentrum in der Nähe

*Audi Centrum Amsterdam
Klokenbergweg 19
1101 AK Amsterdam Zuidoost
Niederlande
Telefon +31 20 5646464*



-  *Circuit Park Zandvoort*
-  *Audi Zentrum (Entfernung 37 km)*

5 Spielberg, 01.–02.08.

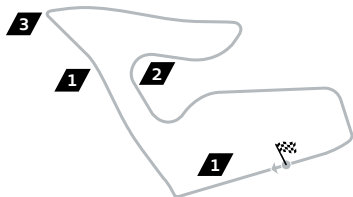

- 1** *Topspeed 230 km/h*
- 2** *Schnellste Kurve 160 km/h*
- 3** *Langsamste Kurve 60 km/h*

4,326 km *Streckenlänge*

ca. 185 km/h
Durchschnittsgeschwindigkeit

31 *Gangwechsel pro Runde*

1.24,588 Min.
Streckenrekord Qualifying
Bruno Spengler (BMW), 2013

1.25,266 Min.
Streckenrekord Rennen
Mike Rockenfeller (Audi), 2014

DTM-Erfolge von Audi in Spielberg

- 7** *Veranstaltungen*
- 7** *Rennen*
- 2** *Siege*
- 0** *Mehrfachsiege*
- 4** *Podestplätze*
- 3** *Pole-Positions*
- 2** *Schnellste Rennrunden*

Audi Zentrum in der Nähe

*Audi Zentrum Rosenheim Ludwig
Kriechbaum GmbH
Innstraße 63
D-83022 Rosenheim
Telefon +49 8031 389370*

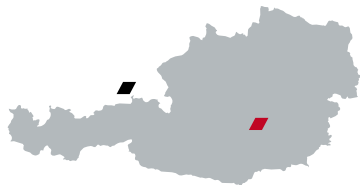

-  *Red Bull Ring Spielberg*
-  *Audi Zentrum (Entfernung 334 km)*

6 Moskau, 29.–30.08.

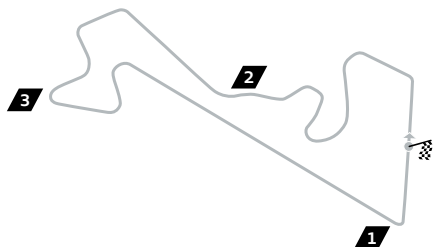

- 1** Toppspeed 245 km/h
- 2** Schnellste Kurve 175 km/h
- 3** Langsamste Kurve 75 km/h

3,931 km Streckenlänge

ca. 160 km/h
Durchschnittsgeschwindigkeit

28 Gangwechsel pro Runde

1.28,523 Min.
Streckenrekord Qualifying
Maxime Martin (BMW), 2014

1.28,305 Min.
Streckenrekord Rennen
Miguel Molina (Audi), 2014

DTM-Erfolge von Audi in Moskau

- 2** Veranstaltungen
- 2** Rennen
- 1** Sieg
- 1** Mehrfachsieg
- 3** Podestplätze
- 1** Pole-Position
- 2** Schnellste Rennrunden

Audi Zentrum in der Nähe

Audi Centr Moskva
Horoshevskoe Shosse, 70, Korpus 1
123007 Moskva
Russland
Telefon +7 495 7979090



-  Moscow Raceway
-  Audi Zentrum (Entfernung 98 km)

7 Oschersleben, 12.–13.09.

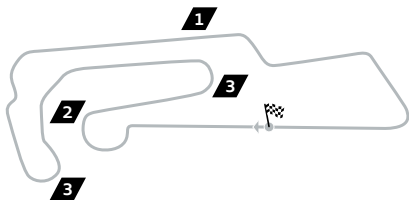

- 1** *Topspeed* 223 km/h
- 2** *Schnellste Kurve* 170 km/h
- 3** *Langsamste Kurve* 100 km/h

DTM-Erfolge von Audi in Oschersleben

- 14** *Veranstaltungen*
- 16** *Rennen*
- 6** *Siege*
- 4** *Mehrfachsiege*
- 18** *Podestplätze*
- 6** *Pole-Positions*
- 8** *Schnellste Rennrunden*

3,696 km *Streckenlänge*

ca. 165 km/h
Durchschnittsgeschwindigkeit

21 *Gangwechsel pro Runde*



1.20,011 Min.
Streckenrekord Qualifying
Adrien Tambay (Audi), 2014

1.21,255 Min.
Streckenrekord Rennen
Joey Hand (BMW), 2013

Audi Zentrum in der Nähe

Audi Zentrum Magdeburg – Feser
August-Bebel-Damm 6
D-39126 Magdeburg
Telefon +49 391 2888677



-  *Motorsport Arena Oschersleben*
-  *Audi Zentrum (Entfernung 46 km)*

8 Nürburgring, 26.–27.09.

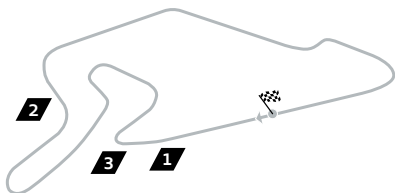

- 1** Toppspeed 240 km/h
- 2** Schnellste Kurve 127 km/h
- 3** Langsamste Kurve 74 km/h

DTM-Erfolge von Audi auf dem Nürburgring

- 25** Veranstaltungen
- 34** Rennen
- 9** Siege
- 3** Mehrfachsiege
- 23** Podestplätze
- 8** Pole-Positions
- 4** Schnellste Rennrunden

3,629 km Streckenlänge

ca. 160 km/h
Durchschnittsgeschwindigkeit

22 Gangwechsel pro Runde

1.22,504 Min.
Streckenrekord Qualifying
Marco Wittmann (BMW), 2014

1.23,175 Min.
Streckenrekord Rennen
Marco Wittmann (BMW), 2014

Audi Zentrum in der Nähe

Audi Zentrum Koblenz GmbH
Friedrich-Mohr-Straße 4
D-56070 Koblenz
Telefon +49 261 808040



-  Nürburgring
-  Audi Zentrum (Entfernung 56 km)

9 Hockenheim, 17.–18.10.

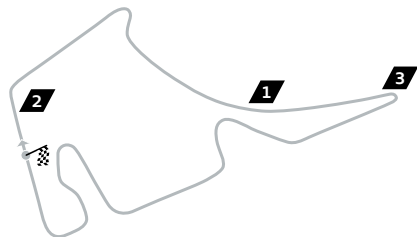

- 1** *Topspeed* 258 km/h
- 2** *Schnellste Kurve* 180 km/h
- 3** *Langsamste Kurve* 65 km/h

4,574 km *Streckenlänge*

ca. 180 km/h
Durchschnittsgeschwindigkeit

32 *Gangwechsel pro Runde*

1.32,244 Min.
Streckenrekord Qualifying
Mattias Ekström (Audi), 2008

1.32,532 Min.
Streckenrekord Rennen
Martin Tomczyk (BMW), 2014

DTM-Erfolge von Audi beim Hockenheim-Finale¹

17 *Veranstaltungen*
35 *gesamt mit Auftakt*

20 *Rennen*
42 *gesamt mit Auftakt*

6 *Siege*
10 *gesamt mit Auftakt*

5 *Mehrfachsiege*
9 *gesamt mit Auftakt*

27 *Podestplätze*
47 *gesamt mit Auftakt*

11 *Pole-Positions*
18 *gesamt mit Auftakt*

4 *Schnellste Rennrunden*
7 *gesamt mit Auftakt*

Audi Zentrum in der Nähe

Audi Zentrum Heidelberg
Hebelstraße 12
D-69115 Heidelberg
Telefon +49 6221 535200



-  *Hockenheimring*
-  *Audi Zentrum (Entfernung 21 km)*

Titel und Erfolge in der DTM



Beste Audi-Fahrer je Saison

1. Platz

1990

Hans-Joachim Stuck

1991

Frank Biela

2002

Laurent Aiello

2004

Mattias Ekström

2007

Mattias Ekström

2008

Timo Scheider

2009

Timo Scheider

2. Platz

2005

Mattias Ekström

2011

Martin Tomczyk

2014

Mattias Ekström

2013

Mike Rockenfeller

3. Platz

2006

Tom Kristensen

2003

Mattias Ekström 4. Platz

2012

Mike Rockenfeller 4. Platz

1992

Frank Biela 15. Platz

2010

Timo Scheider 4. Platz

2001

Laurent Aiello 5. Platz

2000

Laurent Aiello 16. Platz

Siegquote nach Fahrzeugtypen

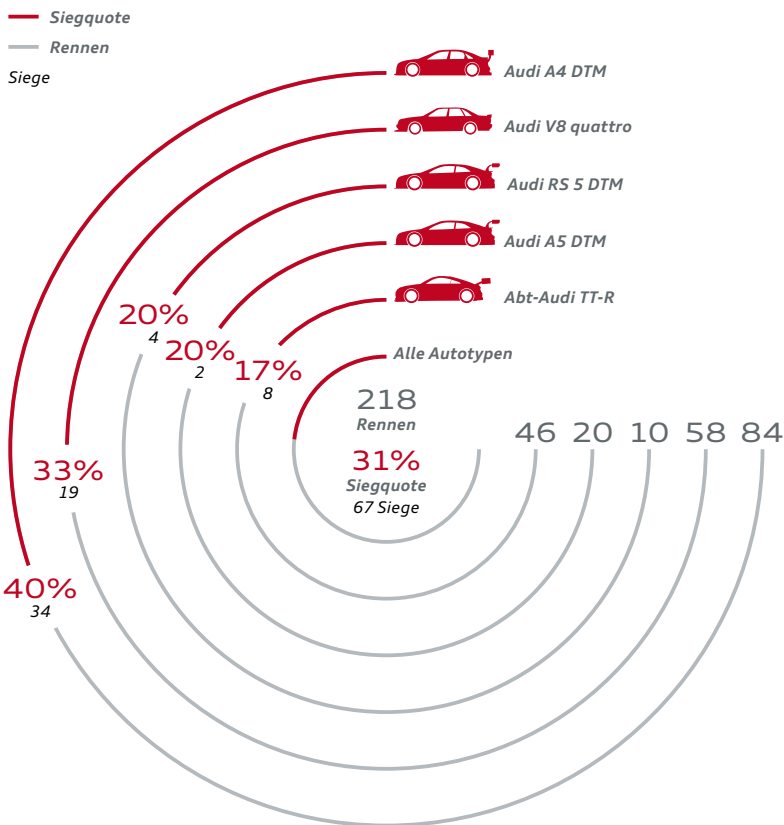

Partner von Audi Sport in der DTM



akrapovic.com



aral.de

Audi
Financial Services

audi.de

Audi
Top Service®

audi.de



autobild.de/auto-test



castrol.de



cisco.com



hoffmann-group.com



oris.ch



playboy.de



redbull.de



schaeffler.de



teufel.de

Weitere Partner



alpinestars.com



eibach.de



gerolsteiner.de



hofmuehl.de



man.eu



oz-racing.de



welt.de

GT-Sport





Inhalt

Audi R8 LMS – Modelljahr 2016	118
Blick in das Cockpit des R8 LMS	120
Einsatzgebiete Audi R8 LMS	122
Schlüsselfunktionen GT-Sport-Programm	124
Härtetest für den neuen R8 LMS	125
Audi R8 LMS Cup	126
Audi race experience	127
Meistertitel (Fahrer) im GT-Sport	128
Gesamtsiege bei Langstrecken-Rennen	130
Partner von Audi Sport customer racing im GT-Sport	131

Audi R8 LMS – Modelljahr 2016

Technischer Fortschritt

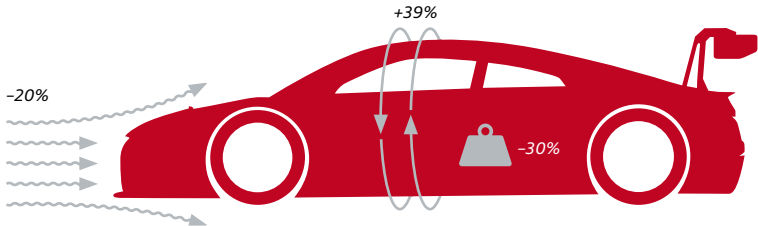

- / Luftwiderstand um 20 Prozent geringer
- / Torsionssteifigkeit des Rahmens um 39 Prozent gestiegen
- / Chassis um 30 kg leichter

Robustheit V10-Motor



- / Nach 10.000 km Laufleistung: erste Inspektion
- / Nach 20.000 km Laufleistung: erste Revision

Erfolgsmodell Audi R8 LMS



Ersatzteillager Audi Sport customer racing



4.943
(inkl. Nachfolger-R8 6.490)
Einzelne Teilepositionen

Teilelieferungen 2014

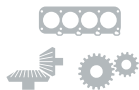

95.490
Teile



1.303
Lieferungen



58
Kunden

Blick in das Cockpit des R8 LMS

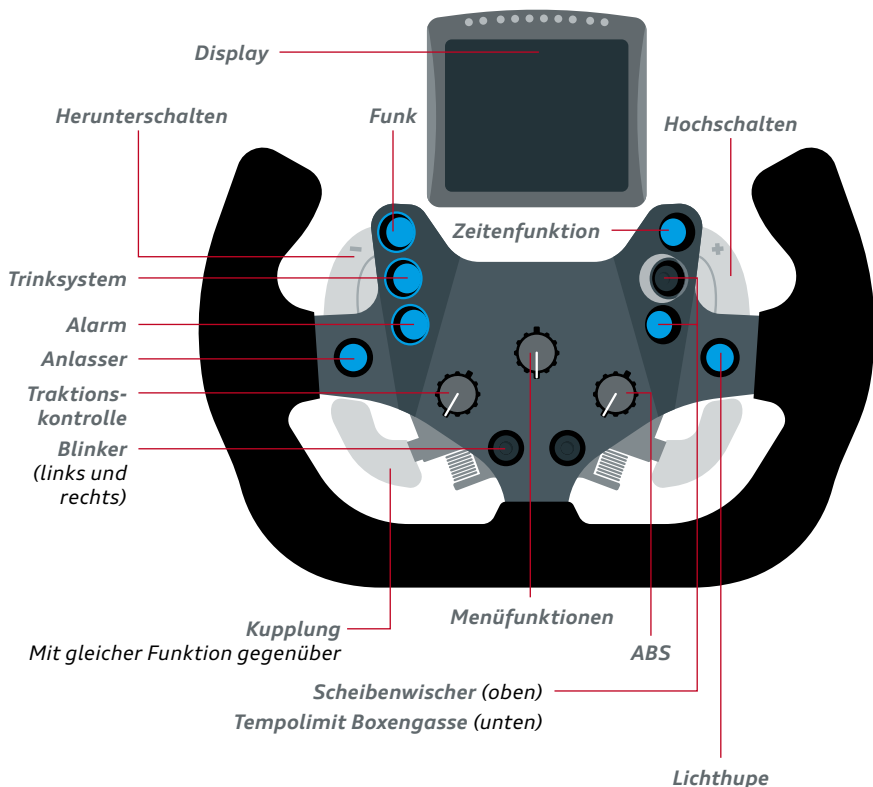

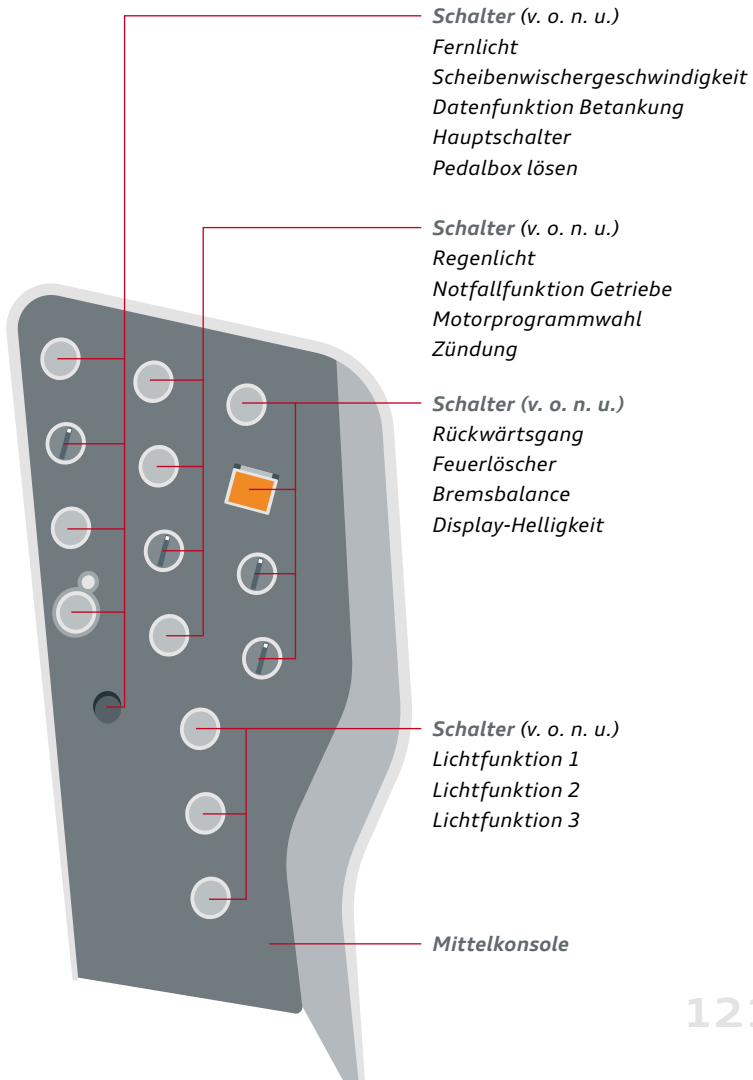

Einsatzgebiete Audi R8 LMS

Langstreckenrennen

12h Abu Dhabi

gulf12hours.com

12h Bathurst

bathurst12hour.com.au

12h Sepang

sepang12hour.com

24h Nürburgring

24h-rennen.de

24h Spa-Francorchamps

total24hours.com

Amerika

Pirelli World Challenge

world-challenge.com

TUDOR United Sports car Championship

imsa.com

Asien

Audi R8 LMS Cup

audir8lmscup.com

GT Asia

afos.com

Super GT

supergt.net/en

Taiwan

pic-taiwan.com

Thailand Super Series

thailandsuperseries.net

Australien

Australien

australiangt.com.au

Europa

ADAC GT Masters

adac-gt-masters.de

DMV Gran Turismo Touring Car Cup

dmv-gtc.de

GT Cup

gtcup.co.uk

Spezial Tourenwagen Trophy

spezial-tourenwagen-trophy.de

VLN

vln.de

British Endurance Championship

britcar24hr.co.uk

Frankreich

gt-tour.fr

Italien

acisportitalia.it/GT

V de V Challenge GT

vdev.fr

International

Blancpain Sprint Series

Blancpain Endurance Series

blancpain-gt-series.com

GT Open

gtopen.net

Schlüsselfunktionen GT-Sport-Programm

Audi Sport customer racing



Peter Mineif
Technischer Projektleiter



Romolo Liebchen
Leiter
Audi Sport customer racing



Dirk Spohr
Leiter
Kundenmagament



Hendrik Többe
Sales/Marketing

Audi race experience



Klaus Demel
Leiter
Audi driving experience



Rainer Kammerbauer
Projektleiter
Audi race experience



Josef Haider
Sportlicher Leiter
Audi race experience

Audi Sport customer racing Asia



Rene Koneberg
Leiter Audi Sport customer racing Asia

Audi Sport customer racing North America



Tristan Herbert
Manager Motorsport & Customer Racing
Audi Sport customer racing North America



Erin Keating
Leitende Eventmanagerin
Audi of America

Härtetest für den neuen R8 LMS

24h Nürburgring (D), 16.–17.05. 

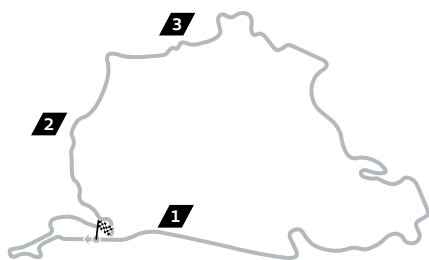

25,378 km
Streckenlänge

ca. 185 km/h
Durchschnittsgeschwindigkeit

4.035,102 km
Distanzrekord
Audi R8 LMS ultra, 2014

- 1** Topspeed 280 km/h
- 2** Schnellste Kurve 240 km/h
- 3** Langsamste Kurve 85 km/h

2
Audi-Siege
2012, 2014

24h Spa-Francorchamps (B), 25.–26.07. 

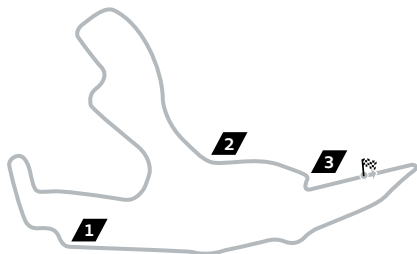

7,004 km
Streckenlänge

ca. 180 km/h
Durchschnittsgeschwindigkeit

4.498,436 km¹
Distanzrekord
Ford Capri RS 2600, 1972

- 1** Topspeed 255 km/h²
- 2** Schnellste Kurve 225 km/h²
- 3** Langsamste Kurve 50 km/h²

3
Audi-Siege
2011, 2012, 2014

¹ Andere Streckenführung

² Werte des alten R8 LMS. Für den neuen R8 LMS noch keine Daten verfügbar

Audi R8 LMS Cup

Terminkalender

- 1** 21.-22.03. Zhuhai (China)
- 2** 16.-17.05. Yeongam (Südkorea)
- 3** Juni/Juli Taiwan
- 4** 08.-09.08. Malaysia
- 5** 10.-11.10. Fuji (Japan)
- 6** 31.10.-01.11. Shanghai (China)

2012

Debütsaison

22

Teilnehmer maximal

Identische Audi R8 LMS

37

kW mehr durch Push-to-Pass

Rennformat

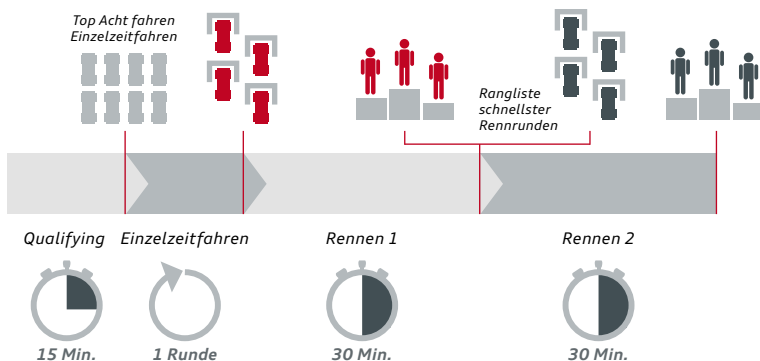

Titel



Gesamt



Amateur-Cup





Team





Four Rings Trophy

Audi race experience



Erlebnis Audi R8 LMS

- ! Rennstreckenerfahrung empfohlen
-  Audi R8 LMS ultra, Audi R8 V10
-  Geführtes und freies Fahren
-  Driving Center Groß Dölln



Erlebnis Audi R8 LMS pro

- ! Rennstreckenerfahrung
-  Audi R8 LMS ultra, Audi R8 V10
-  Geführtes und freies Fahren
-  Driving Center Groß Dölln

Individualtraining Motorsport

- ! Rennstreckenerfahrung sinnvoll
-  Audi R8 LMS ultra, Audi R8 V10, Audi TT cup
-  Individuelle Abstimmung
-  Driving Center Groß Dölln

Erlebnis Audi R8 LMS Kundensport

- ! Motorsportlizenz, Motorsporterfahrung,
Streckenkenntnis Nürburgring-Nordschleife
-  Audi R8 LMS ultra
-  Vorbereitung auf professionellen Motorsport
-  Nürburgring

! Voraussetzung

 Trainingsinhalte

 Trainingsfahrzeug

 Trainingsort

Meistertitel (Fahrer) im GT-Sport



ADAC GT Masters

Christian Abt (D)

Belgien

Jean-François Hemroulle/

Tim Verbergt (B/B)

FIA GT3 (Europa)

Christopher Haase/

Christopher Mies (D/D)



Australien

Mark Eddy (AUS)

Blancpain Endurance Series

Greg Franchi (B)

Italien

Marco Bonanomi (I)

Super Taikyu Series

Tomonobu Fujii/Akihiro Tsuzuki/

Michael Kim (J/J)/USA)

Taça Portugal

César Campaniço/João Figueiredo (P/P)

Spanien

César Campaniço/João Figueiredo (P/P)



DMSB-GT-Meisterschaft

Luca Ludwig (D)

Belgien

Greg Franchi/Anthony Kumpen (B/B)

Portugal

César Campaniço/

João Figueiredo (P/P)

Spanien

César Campaniço/

João Figueiredo (P/P)



2012

Blancpain Endurance Series

*Christopher Haase/Christopher Mies/
Stéphane Ortelli (D/D/MC)*

Portugal

César Campaniço/Carlos Vieira (P/P)

Taça Portugal

César Campaniço/Carlos Vieira (P/P)

Iberian Supercars Trophy

César Campaniço/Carlos Vieira (P/P)

Spanien

Mikko Eskelinen (FIN)



2014

ADAC GT Masters

*Kelvin van der Linde/
René Rast (ZA/D)*

Blancpain Endurance Series

Laurens Vanthoor (B)

Blancpain GT Series

Laurens Vanthoor (B)



2013

Belgien

*Anthony Kumpen/Bert Longin/
Maarten Makelberge (B/B/B)*

FIA GT Series

*Stéphane Ortelli/
Laurens Vanthoor (MC/B)*

GT Sprint International

Thomas Schöffler (D)

Portugal

César Campaniço (P)

Schweden

Jan Brunstedt (S)

Gesamtsiege bei Langstrecken-Rennen



12h Ungarn

*Thomas Gruber/Philip König/
Walter Lechner/
Niki Mayr-Melnhof (A/A/A/A)*



12h Bathurst

*Marc Basseng/Christopher Mies/
Darryl O'Young (D/D/HK)*



12h Bathurst

*Christer Jöns/Christopher Mies/
Darryl O'Young (D/D/HK)*

24h Spa

*Mattias Ekström/Greg Franchi/
Timo Scheider (S/B/D)*

24h Zolder

*Enzo Ide/Bert Longin/
Xavier Maassen/
François Verbist (B/B/B/B)*

24h Nürburgring

*Marc Basseng/Christopher Haase/
Frank Stippler/
Markus Winkelhock (D/D/D/D)*



24h Nürburgring

*Christopher Haase/
Christian Mamerow/
René Rast/
Markus Winkelhock (D/D/D/D)*

24h Spa

*Andrea Piccini/René Rast/
Frank Stippler (I/D/D)*

24h Zolder

*Marco Bonanomi/Anthony Kumpen/
Edward Sandström/
Laurens Vanthoor (I/B/S/B)*

24h Spa

*René Rast/Laurens Vanthoor/
Markus Winkelhock (D/B/D)*

Partner von Audi Sport customer racing im GT-Sport



**Audi Sport
TT Cup**





Inhalt

Audi Sport TT Cup – Entwicklung in Rekordzeit	136
Dauererprobung im Motorland Aragón	137
Push-to-Pass – mehr Power auf Knopfdruck	138
Überholvorgang mit Push-to-Pass	139
Blick in das Cockpit des Cup-Rennwagens	140
Schlüsselfunktionen im Audi Sport TT Cup	142
Zentraler Einsatz der Cup-Rennwagen	143
Der Audi Sport TT Cup	144
Fahrer Audi Sport TT Cup	146
Partner im Audi Sport TT Cup	150

Audi Sport TT Cup – Entwicklung in Rekordzeit

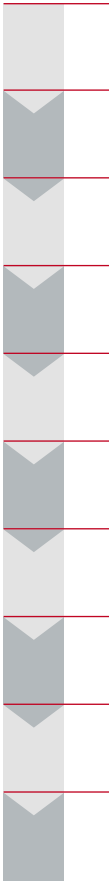

KW 19/2014

Projektstart Audi Sport TT Cup

KW 31/2014

Fertigstellung des Chassis

KW 41/2014

Fertigstellung des ersten Prototyps und Roll-out

KW 42/2014

Präsentation beim DTM-Finale in Hockenheim

KW 46/2014

Fertigstellung des ersten Testautos

KW 04/2015

Verkündung des Fahrerkaderns

KW 06/2015

Dauererprobung in Aragón

KW 08/2015

Beginn der Produktion von 35 Einheiten

KW 10/2015

Fitnesscamp und erster Test der Fahrer

KW 18/2015

Saisonauftritt mit zwei Rennen in Hockenheim

Dauererprobung im Motorland Aragón

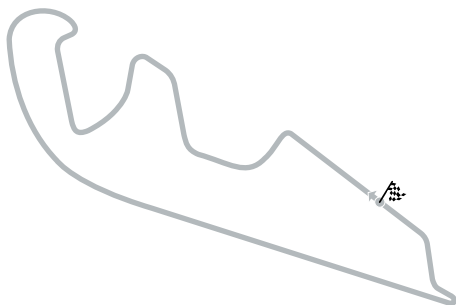

4
Tage

32
Stunden

5.200 km
Kilometer

2
Testfahrer
Miguel Molina,
Marco Werner

Technologietransfer

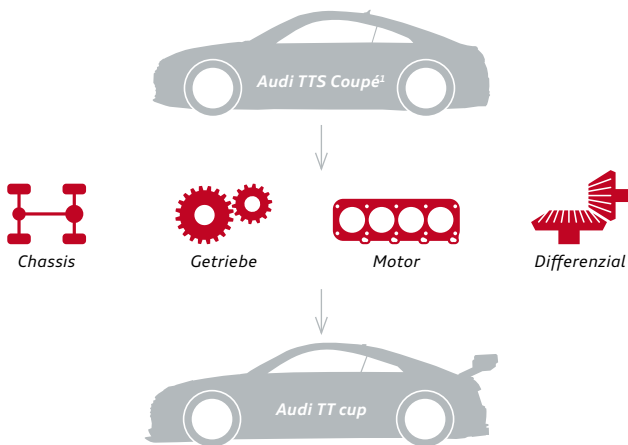

¹ Die Verbrauchs- und Emissionswerte entnehmen Sie der Auflistung auf Seite 151

Push-to-Pass – mehr Power auf Knopfdruck

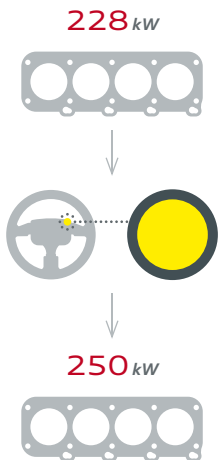

Motorleistung

Durch das Aktivieren des Push-to-Pass-Systems lässt sich die Leistung des Cup-Rennwagens kurzfristig um 22 kW steigern. Dauer und Anzahl der Push-to-Pass-Vorgänge werden an die jeweilige Strecke angepasst

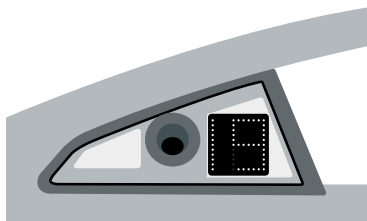

Anzahl Push-to-Pass-Vorgänge

Angezeigt durch weiße LEDs in den hinteren Seitenscheiben



Push-to-Pass in Benutzung

Angezeigt durch blaue Lampen in der Windschutzscheibe

Überholvorgang mit Push-to-Pass



Blick in das Cockpit des Cup-Rennwagens

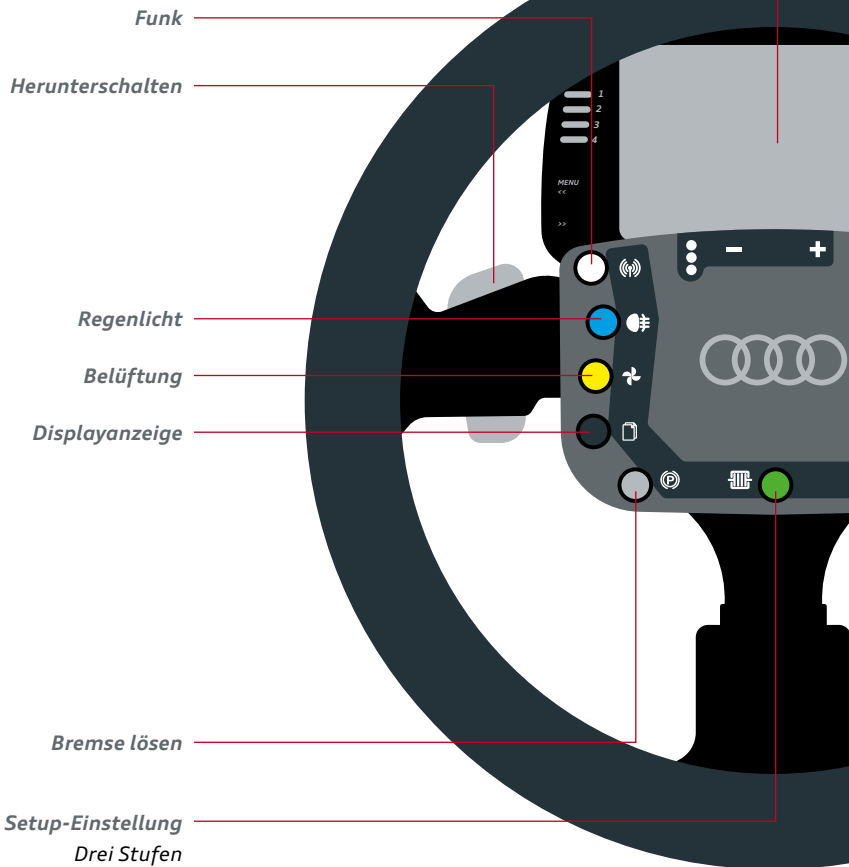

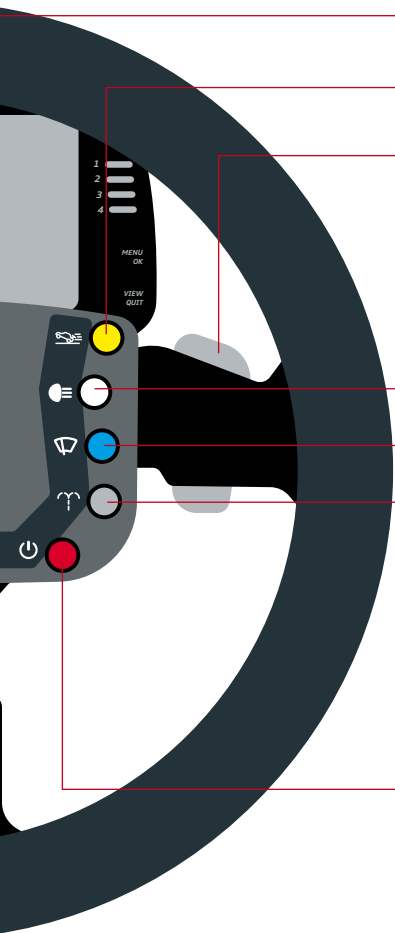

Display

Push-to-Pass

Hochschalten

Fernlicht

Scheibenwischer

Scheibenwasser

Anlasser

Wenn Auto nicht in Bewegung

Tempolimit Boxengasse

Wenn Auto in Bewegung

Schlüsselfunktionen im Audi Sport TT Cup



Rolf Michl
Projektleiter



Manuel Jahn
Vermarktung/Partnerschaften



Christiane Fritz
Vermarktung/Partnerschaften



Detlef Schmidt
Technischer Projektleiter

Zentraler Einsatz der Cup-Rennwagen

Permanente Starter



Gaststarter



Zentraler Einsatz der Rennfahrzeuge Durch quattro GmbH

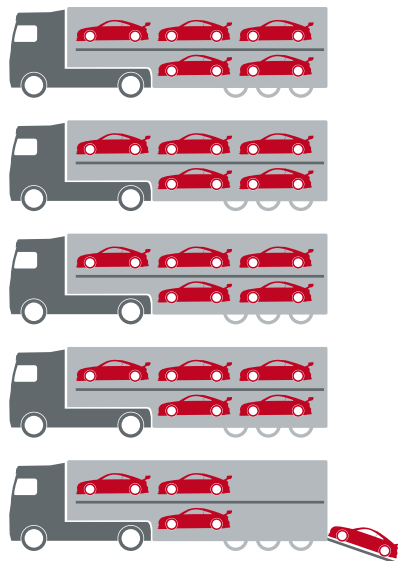

Individuelle Einstellmöglichkeiten für die Fahrer

- / Positionen Lenkrad, Pedale, Sitz und Sicherheitsgurt
- / Vorderer und hinterer Stabilisator
- / Reifendruck innerhalb der vorgegebenen Grenzwerte
- / Traction Control System (TCS)
- / Differenzial-Mapping in drei Modi

Alle anderen Parameter werden ausschließlich vom beauftragten Generalunternehmen an allen Fahrzeugen einheitlich eingestellt.

Der Audi Sport TT Cup

Alle Veranstaltungen im Rahmen der DTM



- 1** Hockenheim
- 2** Norisring
- 3** Spielberg
- 4** Oscherleben
- 5** Nürburgring
- 6** Hockenheim

Rennformat

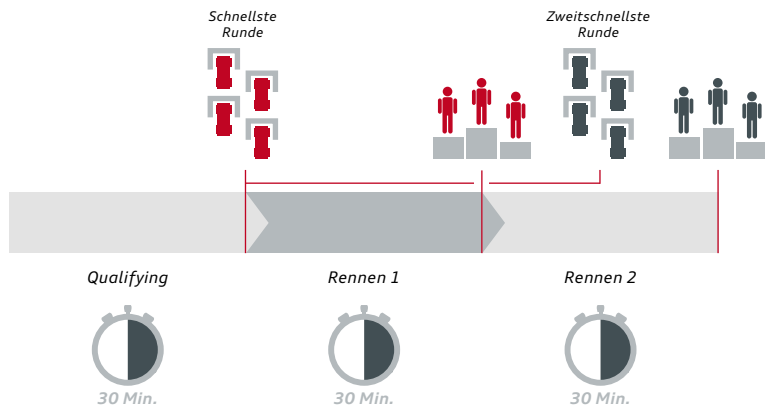

Starter

18 permanente Starter (Alter, Geschlecht, Nation)

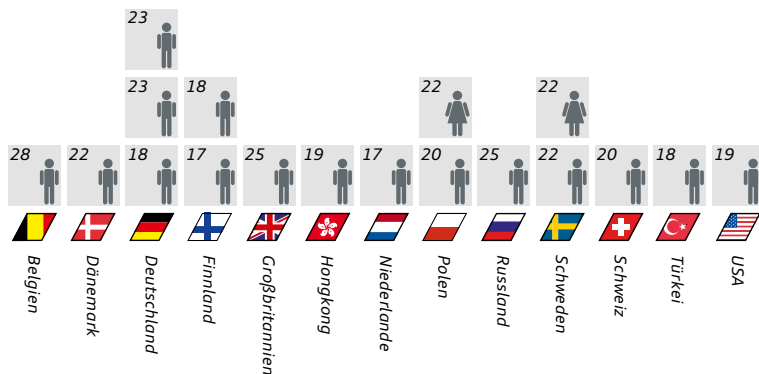

6 Gaststarter pro Event



Prominente



Journalisten



Rennsport-Legenden

Alle Gaststarter müssen im Besitz einer internationalen Rennlizenz sein und im Vorfeld des Einsatzes an einer von der quattro GmbH über die Audi driving experience durchgeführten speziellen Qualifizierung teilnehmen.

Social-Buzz-Ranking



- / Aktivität der Fahrer bei Facebook
- / Ranking auf audi-motorsport.com
- / Gewinner erhalten Preise

Wichtige Links

Audi Sport TT Cup

#AudiSport

#TTCup

#challengerswelcome

 audi-motorsport.com

 [AudiSport](https://www.facebook.com/AudiSport)

 [@Audi__Sport](https://twitter.com/Audi__Sport)

Fahrer Audi Sport TT Cup

Starterliste

- #3 Gosia Rdest (PL) 
- #5 Nikita Misyulya (RUS) 
- #7 Christoph Hofbauer (D) 
- #8 Shaun Thong (HK) 
- #9 Kaan Önder (TR) 
- #11 Levin Amweg (CH) 
- #14 Josh Caygill (GB) 
- #17 Nicolaj Møller Madsen (DK) 
- #26 Dominik Peitz (D) 
- #27 Dennis Marschall (D) 
- #33 Emil Lindholm (FIN) 
- #43 Jan Kisiel (PL) 
- #45 Joonas Lappalainen (FIN) 
- #49 Sebastian Landy (USA) 
- #50 Loris Hezemans (NL) 
- #55 Alexis van de Poele (B) 
- #89 Mikaela Åhlin-Kottulinsky (S) 
- #92 Anton Marklund (S) 

Gosia
Rdest 



- * 14.01.1993, Żyrardów (PL)
- ▲ Krakau (PL)
- i Mächte als erste Frau auf dem Mond landen

 Gosia-Rdest-Life-is-a-Race

Nikita
Misyulya 



- * 23.04.1990, Kaunas (LT)
- ▲ Samara (RUS)
- i Fuhr fünf Jahre im russischen Trial-Radsport-Nationalteam

 Nikita.Misyulya

Christoph
Hofbauer 



- * 15.07.1991, Kösching (D)
- ▲ Lippertshofen (D)
- i Isst am liebsten Schweinshaxe

 christoph.racing

Shaun Thong 



- * 01.11.1995, Hongkong (HK)
- ▲ Hongkong (HK)
- i Macht am liebsten Urlaub auf den Malediven und Tahiti

 Shaun-Thongs-fans-page

Kaan Önder 



- * 10.01.1997, Istanbul (TR)
- ▲ Istanbul (TR)
- i Meditiert gerne vor dem Rennstart

 kaanonder1

Levin Amweg 



- * 11.09.1994, Bern (CH)
- ▲ Bremgarten (CH)
- i Wäre alternativ gern Investmentbanker geworden

 levin.amweg

Josh Caygill 



- * 22.06.1989, Huddersfield (GB)
- ▲ Huddersfield (GB)
- i Führt am liebsten auf dem Thruxton Circuit in Hampshire

 joshcaygillracing

Nicolaj Møller Madsen 



- * 10.03.1993, Odense (DK)
- ▲ Sønderø (DK)
- i Orientiert sich beim Fahrstil an Allan Simonsen

 Mollerermadsenfan

Dominik Peitz 



- * 20.11.1991, Gütersloh (D)
- ▲ Verl (D)
- i Lieblingsstrecken: Nordschleife, Sachsenring und Bilster Berg

 [DominikPeitzMotorsport](#)

Dennis Marschall 



- * 15.08.1996, Karlsruhe (D)
- ▲ Eggenstein (D)
- i Wiegt bei einer Körpergröße von 1,83 m nur 65 kg

 [Dennis-Marschall-Offizielle-Fanpage](#)

Emil Lindholm 



- * 19.07.1996, Espoo (FIN)
- ▲ Degerby (FIN)
- i Hört gerne Musik von Queen

 [ELindholmRacing](#)

Jan Kisiel 



- * 14.07.1994, Warschau (PL)
- ▲ Warschau (PL)
- i Ist ausgebildeter Helikopterpilot

 [KisielRacing](#)

Joonas Lappalainen 



- * 01.03.1998, Vantaa (FIN)
- ▲ Vantaa (FIN)
- i Wäre alternativ gerne Fußballer geworden

 [joonaslappalainenofficial](#)

Sebastian
Landy 



- * 14.12.1995, Fairfax (USA)
- ▲ Great Falls (USA)
- i Verbringt seinen Urlaub am liebsten zu Hause

 [sebastianlandyracing](#)

Loris
Hezemans 



- * 26.05.1997, Amsterdam (NL)
- ▲ Uccle (B)
- i Lieblingsmusiker ist der verstorbene Rapper Tupac Shakur

 [lorishezemansfanpage](#)

Alexis
van de Poele 



- * 21.06.1989, Incourt (B)
- ▲ Incourt (B)
- i Möchte gerne nach Tansania reisen

 [alexis.vandepoele](#)

Mikaela Åhlin-
Kottulinsky 



- * 13.11.1992, Karlstad (S)
- ▲ Hammarö (S)
- i Hat Golferin Annika Sörenstam als Vorbild

 [MikaelaAhlinKottulinskyFanpage](#)

Anton
Marklund 



- * 09.12.1992, Skelleftea (S)
- ▲ Boliden (S)
- i Geht in der Freizeit gern zur Jagd

 [marklundanton](#)

Partner im Audi Sport TT Cup

Audi
Original Zubehör



audi.de/zubehoer

Audi
Top Service®

audi.de

Auto Bild **sportscars**

autobild.de/sportscars

HANKOOK

hankooktire.com

LG Chem

lgchem.com

REHAU
Ultimate Polymer Solutions

reha.com

Weitere Partner

Audi
Consulting



audi-consulting.de

AMAG
AUSTRIA METALL

amag.at

PAGID/RS

pagidracing.com

Verbrauchswerte

Angaben zu den Kraftstoffverbräuchen und CO₂-Emissionen sowie Effizienzklassen bei Spannweiten in Abhängigkeit vom verwendeten Reifen-/Rädersatz:

Audi A1

Kraftstoffverbrauch kombiniert:
7,3-3,4 l/100 km

CO₂-Emission kombiniert: 168-89 g/km

Audi A3

Kraftstoffverbrauch kombiniert:
8,3-1,5 l/100 km

CO₂-Emission kombiniert: 194-35 g/km

Audi RS 4 Avant

Kraftstoffverbrauch kombiniert:
10,7 l/100 km

CO₂-Emission kombiniert: 249 g/km

Audi A6

Kraftstoffverbrauch kombiniert:
9,6-4,2 l/100 km

CO₂-Emission kombiniert: 224-109 g/km

Audi Q3

Kraftstoffverbrauch kombiniert:
8,4-4,4 l/100 km

CO₂-Emission kombiniert: 198-114 g/km

Audi Q5

Kraftstoffverbrauch kombiniert:
8,5-4,9 l/100 km

CO₂-Emission kombiniert: 199-129 g/km

Audi RS 7 Sportback

Kraftstoffverbrauch kombiniert:
9,5 l/100 km

CO₂-Emission kombiniert: 221 g/km

Audi TTS Coupé

Kraftstoffverbrauch kombiniert:
7,3-6,8 l/100 km

CO₂-Emission kombiniert: 169-157 g/km

Audi RS 3 Sportback

Kraftstoffverbrauch kombiniert:
8,3-8,1 l/100 km

CO₂-Emission kombiniert: 194-189 g/km

Audi RS 5

Kraftstoffverbrauch kombiniert:
10,7-10,5 l/100 km

CO₂-Emission kombiniert: 249-246 g/km

Audi RS 6 Avant

Kraftstoffverbrauch kombiniert:
9,6 l/100 km

CO₂-Emission kombiniert: 223 g/km

Audi RS Q3

Kraftstoffverbrauch kombiniert:
8,4 l/100 km

CO₂-Emission kombiniert: 198 g/km

Audi Q7

Kraftstoffverbrauch kombiniert:
8,3-5,7 l/100 km

CO₂-Emission kombiniert: 193-149 g/km

Audi R8 Coupé

Kraftstoffverbrauch kombiniert:
14,9-12,4 l/100 km

CO₂-Emission kombiniert: 346-289 g/km

Stand: 27. April 2015

Kontakte



Kontakte



Jürgen Pippig

Leiter Kommunikation Motorsport

Tel. +49 841 89-35550

Mobil +49 160 90430634

E-Mail juergen.pippig@audi.de



Virginia Brusch

*Kommunikation GT-Sport
und Audi Sport TT Cup*

Tel. +49 841 89-41753

Mobil +49 151 52817968

E-Mail virginia.brusch@audi.de



Daniel Schuster

Kommunikation DTM

Tel. +49 841 89-38009

Mobil +49 151 42134732

E-Mail daniel2.schuster@audi.de



Petra Strack

Kommunikation Motorsport

Tel. +49 841 89-44784

Mobil +49 172 9101025

E-Mail petra.strack@audi.de



Eva-Maria Veith

Kommunikation LMP

Tel. +49 841 89-33922

Mobil +49 173 9393522

E-Mail eva-maria.veith@audi.de

*Fotos und Informationen erhalten Sie unter
audi-motorsport.info und audi-mediaservices.com*

*Digitale Pressemappen zu allen vier Motorsportprogrammen finden Sie unter
digital.audi-presskit.de*

AUDI AG
Kommunikation Motorsport
D-85045 Ingolstadt

Telefon +49 841 8934200
E-Mail motorsport-media@audi.de

